

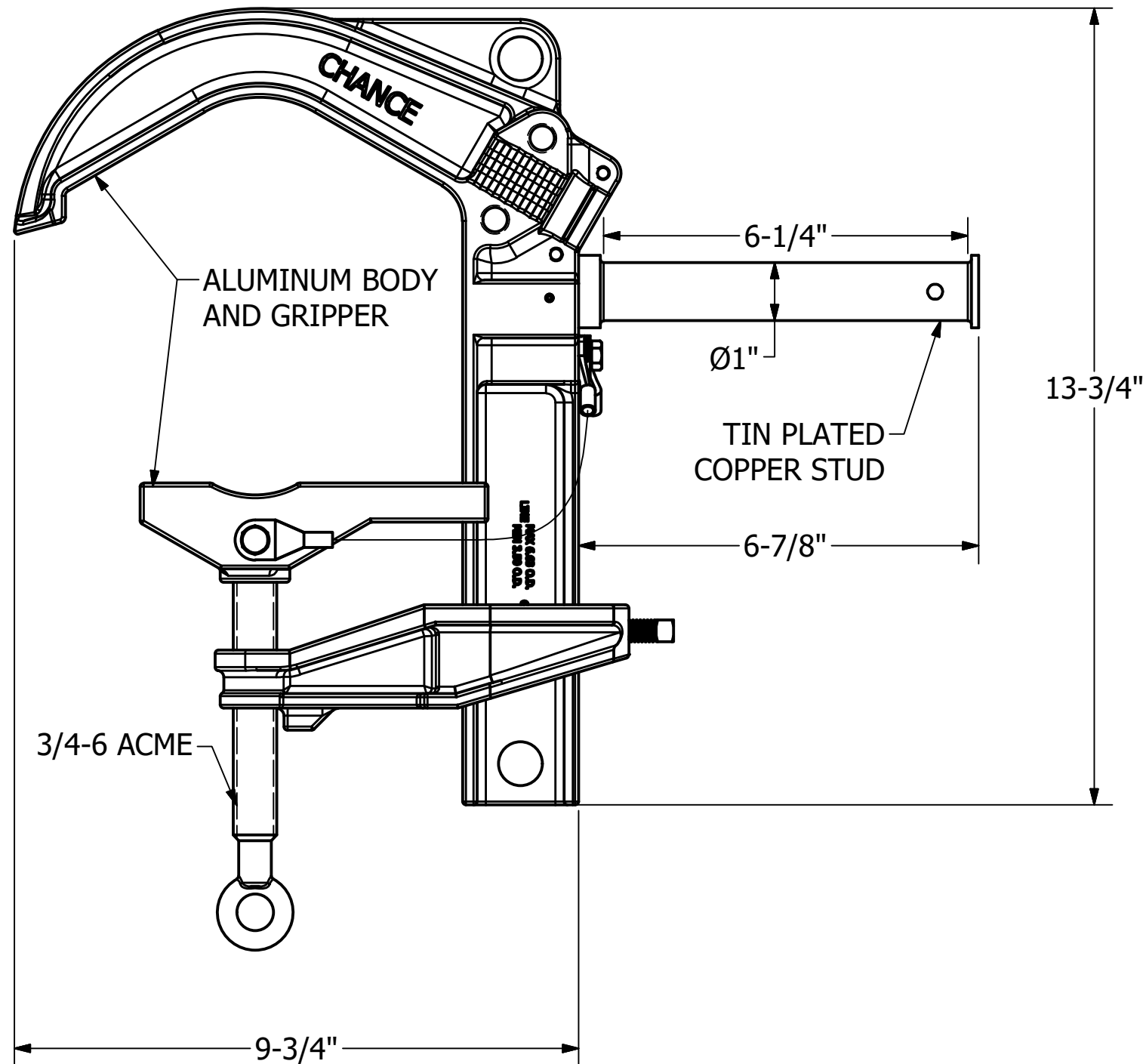

Catalog Number

PSC6003643



Continuous Current (Amps)	400
Rated Fault Current - 15 Cycles	68 kA Asymmetrical
Recommended Torque (in-lb)	300
Main Line Range - Max.	6-5/8" OD Bus
Main Line Range - Min.	3-1/2" OD Bus
ASTM Grade	7H

CHANCE [®]	 HUBBELL POWER SYSTEMS, INC.			
	TITLE BUS BAR GROUND CLAMP, 1" DIA STUD			
<small>CONFIDENTIAL: THIS DRAWING AND ITS CONTENTS ARE CONFIDENTIAL AND THE EXCLUSIVE PROPERTY OF HUBBELL POWER SYSTEMS. NO PUBLICATION, DISTRIBUTION, OR COPIES MAY BE MADE WITHOUT THE WRITTEN CONSENT OF HUBBELL POWER SYSTEMS. HUBBELL POWER SYSTEMS UNPUBLISHED ALL RIGHTS RESERVED UNDER THE COPYRIGHT LAWS.</small>	SIZE B	CAT / PART / ASSY NO. PSC6003643	DWG NO. SA6003643	REV B
	<small>DO NOT SCALE THIS DRAWING</small>	DRN BY TLK	DATE 10/9/19	SHEET 1 OF 1