

CATALOG NUMBER

PSC6003700

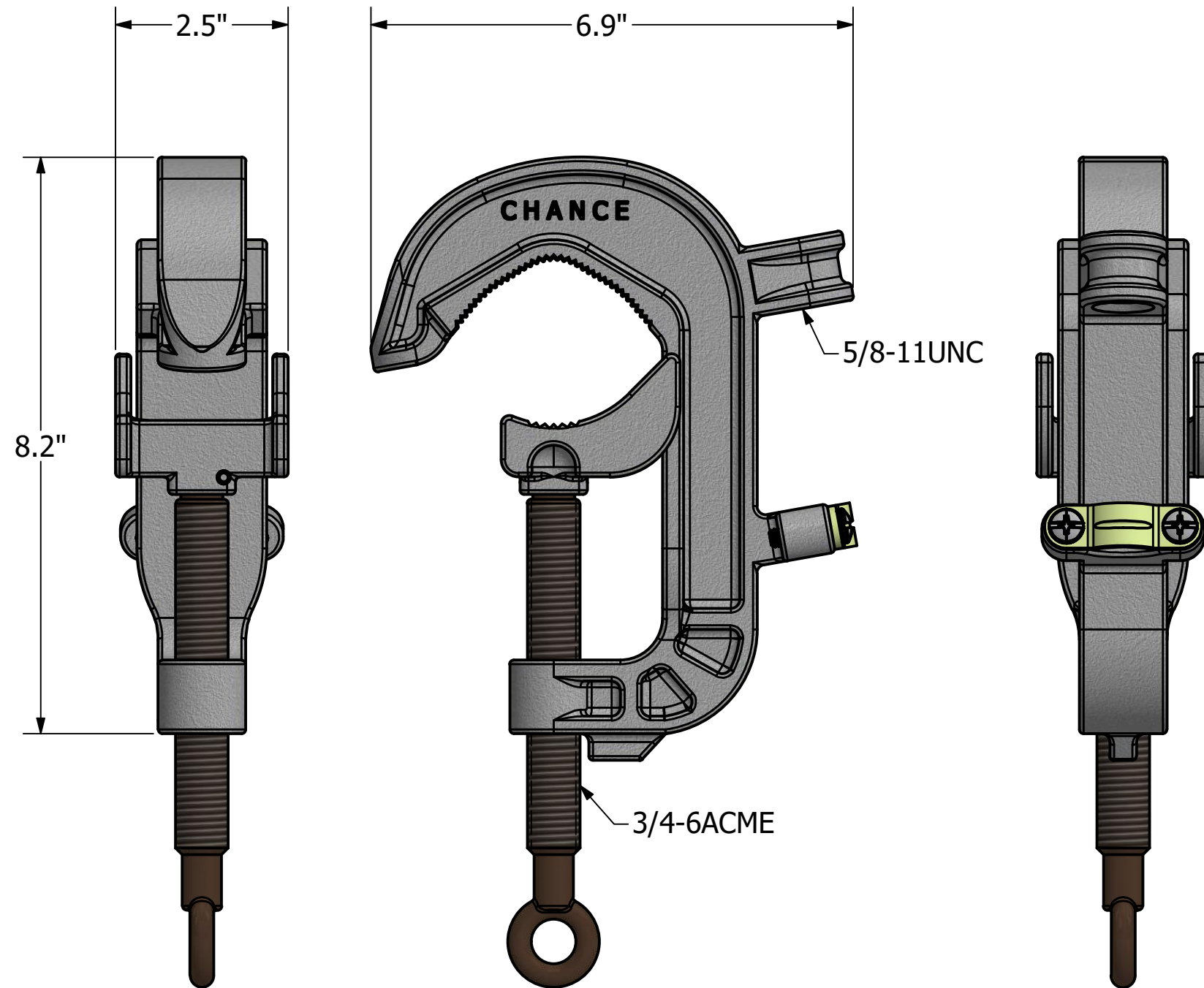

ASTM Grade	6H
Rated Current - 15 Cycles	55 kA
Required Torque	300 in-lb
Max. Line Range	2.88" Dia
Min. Line Range	0.625" Dia
Jaw Type	Serrated

CHANCE®



HUBBELL POWER SYSTEMS, INC.

TITLE
SERRATED C-TYPE GROUND CLAMP, 0.625"-2.88"

CONFIDENTIAL: THIS DRAWING AND ITS CONTENTS ARE CONFIDENTIAL AND THE EXCLUSIVE PROPERTY OF HUBBELL POWER SYSTEMS. NO PUBLICATION, DISTRIBUTION, OR COPIES MAY BE MADE WITHOUT THE WRITTEN CONSENT OF HUBBELL POWER SYSTEMS. HUBBELL POWER SYSTEMS UNPUBLISHED ALL RIGHTS RESERVED UNDER THE COPYRIGHT LAWS.

SIZE B	CAT / PART / ASSY NO. PSC6003700	DWG NO. SA6003700	REV B
DO NOT SCALE THIS DRAWING	DRN BY TLK	DATE 3/29/21	SHEET 1 OF 1