

==NOTES==

1. MAT'L: HOT ROLLED STEEL.
2. HOT DIP GALVANIZE PER ASTM A153-(LATEST REVISION).
3. PACKAGE PER SPEC. TT3-6500.

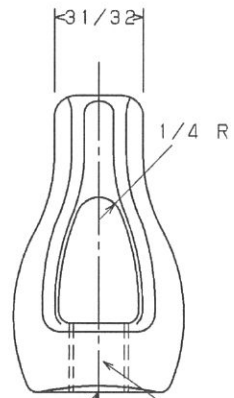
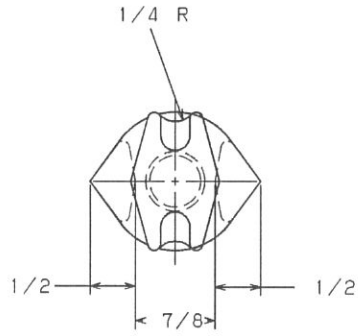

MANUFACTURER'S SYMBOL  
IN 3/16" RAISED LETTERS

THREAD SIZE "B"  
DRILLED & TAPPED  
AFTER GALVANIZING

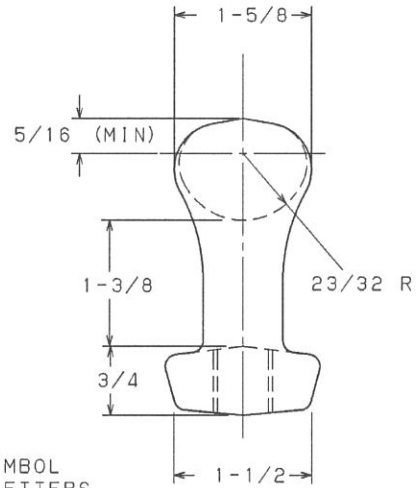

QTY	ITEM	PART NO.	MATERIAL	DESCRIPTION	"B"
1		P 012042		3 NOTE 1 THIMBLEYE NUT	.695-11NS-2B
1		P 451175		2 NOTE 1 THIMBLEYE NUT	.771-10NS-2B
1		P 451174		1 NOTE 1 THIMBLEYE NUT	.646-11NS-2B

REV.	DATE	BY	APPD	REV.

ISO DUAL DIMENSIONS (IF ANY)  
IN = INCH, MM = MILLIMETER

THIRD ANGLE PROJECTION

THIMBLEYE NUT

SIZE C

DRN. MV 08-27-90  
CHK. MV 08-27-90  
DSGN. --  
APPD. JTO 08-27-90

**HUBBELL** POWER SYSTEMS **CHANCE** SA-6509

CONFIDENTIAL: THIS DRAWING AND ITS CONTENTS ARE CONFIDENTIAL AND THE EXCLUSIVE PROPERTY OF HUBBELL / A. B. CHANCE COMPANY. NO PUBLICATION, DISTRIBUTION OR COPIES MAY BE MADE WITHOUT WRITTEN CONSENT BY HUBBELL / A. B. CHANCE COMPANY. © 2000 HUBBELL/A. B. CHANCE. UNPUBLISHED - ALL RIGHTS RESERVED UNDER THE COPYRIGHT LAWS

DO NOT SCALE THIS DWG