

NOTES

1. MATERIAL: C1018 HOT ROLLED STEEL
2. .40 R GROOVES MUST BE TRIMMED SMOOTH
3. HOT DIP GALVANIZED PER ASTM A153 (LATEST REVISION)
4. 1.021-8NS-2B THREAD
5. STAMP "C" MUST BE READABLE AFTER GALVANIZING
6. ADD USA SUFFIX TO CATALOG NUMBER FOR BUY AMERICA ITEMS. PURCHASERS OF BUY AMERICA ITEMS WILL BE PROVIDED A DATED CERTIFICATE OF COMPLIANCE TO SPECIFIC BUY AMERICA PROVISIONS IF REQUESTED AT THE TIME OF ORDER. CONTACT HUBBELL POWER SYSTEMS CUSTOMER SERVICE FOR DETAILS.

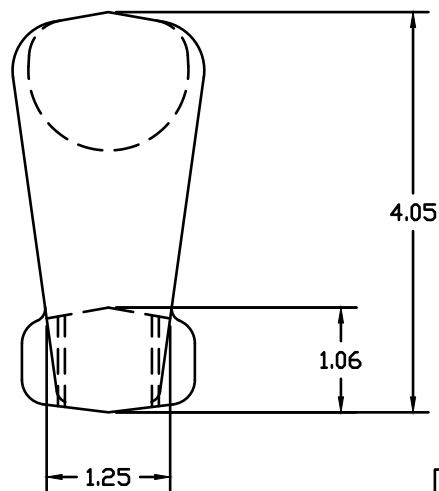
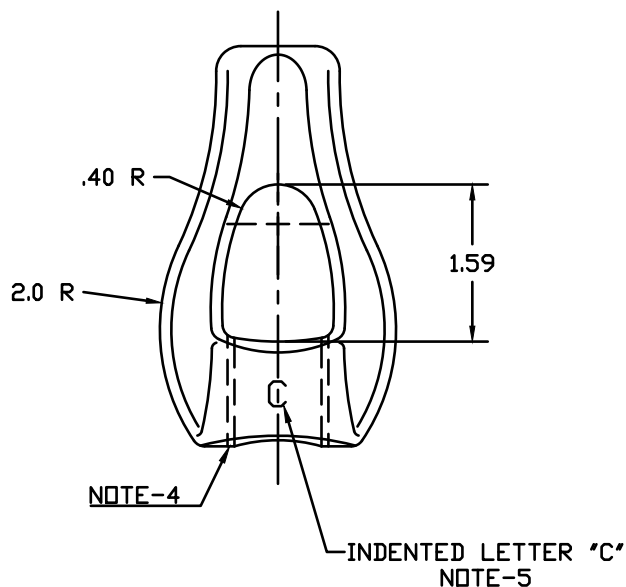

<i>CAT. NO.</i>
6512

CHANCE TOLERANCE CHART		HUBBELL POWER SYSTEMS		
CONFIDENTIAL: THIS DRAWING AND ITS CONTENTS ARE CONFIDENTIAL AND THE EXCLUSIVE PROPERTY OF HUBBELL POWER SYSTEMS. NO PUBLICATION, DISTRIBUTION OR COPIES MAY BE MADE WITHOUT THE WRITTEN CONSENT OF HUBBELL POWER SYSTEMS. HUBBELL POWER SYSTEMS UNPUBLISHED ALL RIGHTS RESERVED UNDER THE COPYRIGHT LAWS.		TITLE NUT, THIMBLEYE		
		SIZE B	DWG NO. SA6512	CAT / PART / ASSY NO. 6512
DO NOT SCALE THIS DRAWING	DRN BY TLW	DATE 2/28/11	SHEET 1 OF 1	