

- NOTES-
- MAT'L: 3-1/2 X 2-1/2 X 5/16 STEEL ANGLE, HOT DIP GALV. PER ASTM A153 (LATEST REV.)

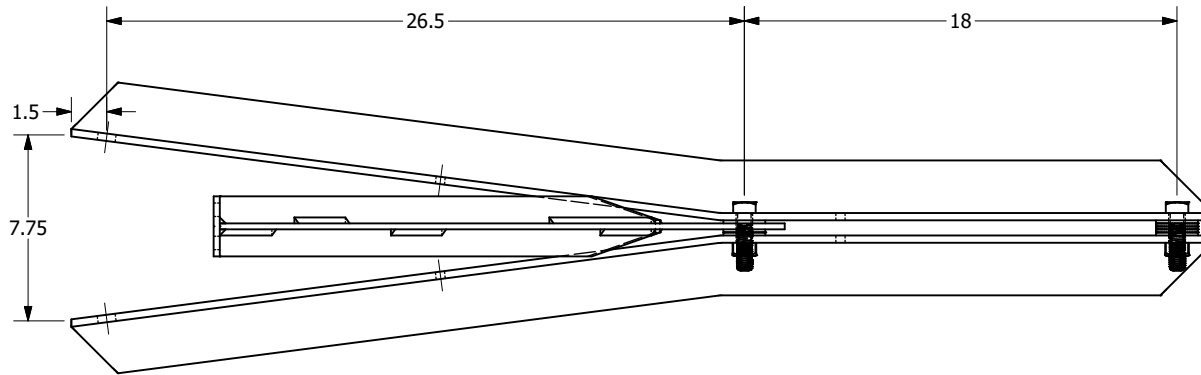

CATALOG NUMBER 7921

CHANCE [®]		HUBBELL [®] POWER SYSTEMS, INC.	
TITLE			
CABLE EXTENSION ARM			
SIZE	CAT / PART / ASSY NO.	DWG NO.	REV
C	SA7921	7921	C
DO NOT SCALE THIS DRAWING	DRN BY SCRIVNER	DATE 08/28/90	SHEET 1 OF 1

CONFIDENTIAL: THIS DRAWING AND ITS CONTENTS ARE CONFIDENTIAL AND THE EXCLUSIVE PROPERTY OF HUBBELL POWER SYSTEMS. NO PUBLICATION, DISTRIBUTION, OR COPIES MAY BE MADE WITHOUT THE WRITTEN CONSENT OF HUBBELL POWER SYSTEMS. HUBBELL POWER SYSTEMS UNPUBLISHED ALL RIGHTS RESERVED UNDER THE COPYRIGHT LAWS.