

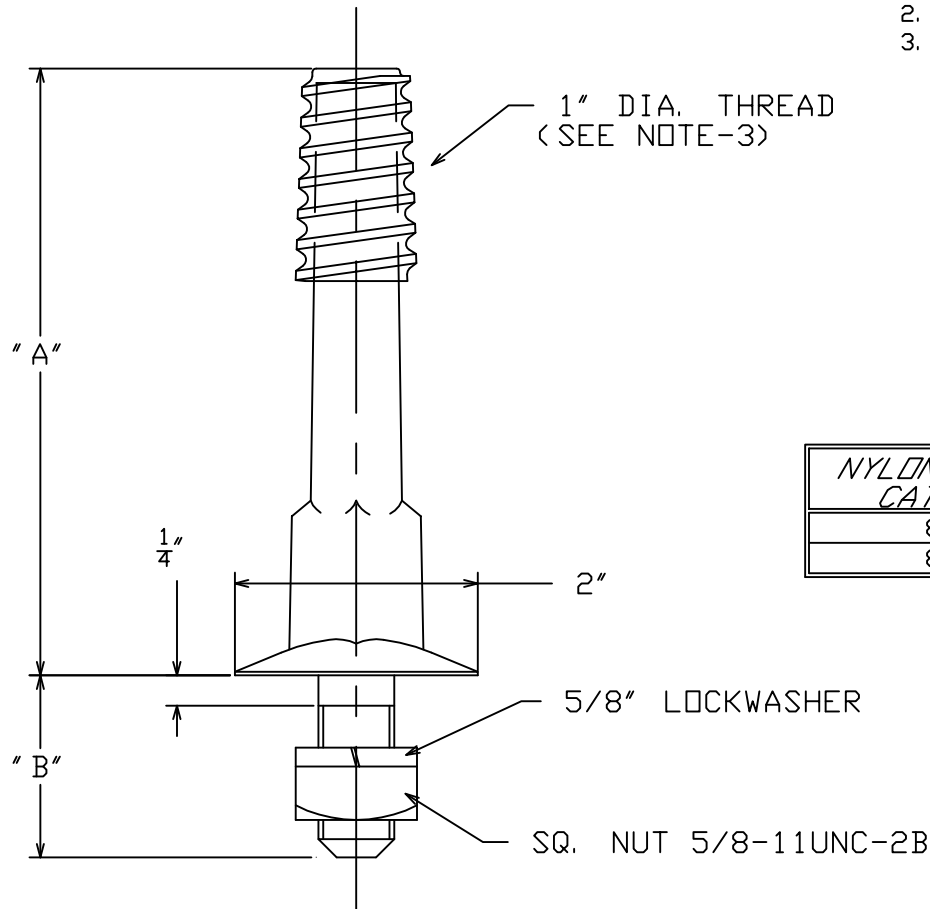

==NOTES==

1. MAT'L: STEEL.
2. HOT DIP GALVANIZE PER ASTM A153-(LATEST REVISION).
3. 1" DIA. THREAD MATERIAL WILL BE CONDUCTIVE NYLON OR LEAD BASED ON CATALOG NUMBER FROM TABLE BELOW.



NYLON THREAD CAT. NO.	LEAD THREAD CAT. NO.	"A"	"B"
886P	886	5	1-1/2
887P	PS887	6	2-1/2

CHANCE TOLERANCE CHART		 HUBBELL® POWER SYSTEMS <small>POWER SYSTEMS, INC.</small>		
<small>CONFIDENTIAL: THIS DRAWING AND ITS CONTENTS ARE CONFIDENTIAL AND THE EXCLUSIVE PROPERTY OF HUBBELL POWER SYSTEMS. NO PUBLICATION, DISTRIBUTION OR COPIES MAY BE MADE WITHOUT THE WRITTEN CONSENT OF HUBBELL POWER SYSTEMS. HUBBELL POWER SYSTEMS UNPUBLISHED ALL RIGHTS RESERVED UNDER THE COPYRIGHT LAWS.</small>		TITLE NYLON THREAD LV PIN		
		SIZE SB SA886P	DWG NO. SA886P	CAT / PART / ASSY NO. SEE CHART
DO NOT SCALE THIS DRAWING		DRN BY MARTIN	DATE 02/04/98	SHEET 1 OF 1