

CATALOG NO.	"A"	"B"	"C"
886	5.0	1.5	1.25
PS887	6.0	2.5	2.25
PSC2061102	6.0	2.5	2.25

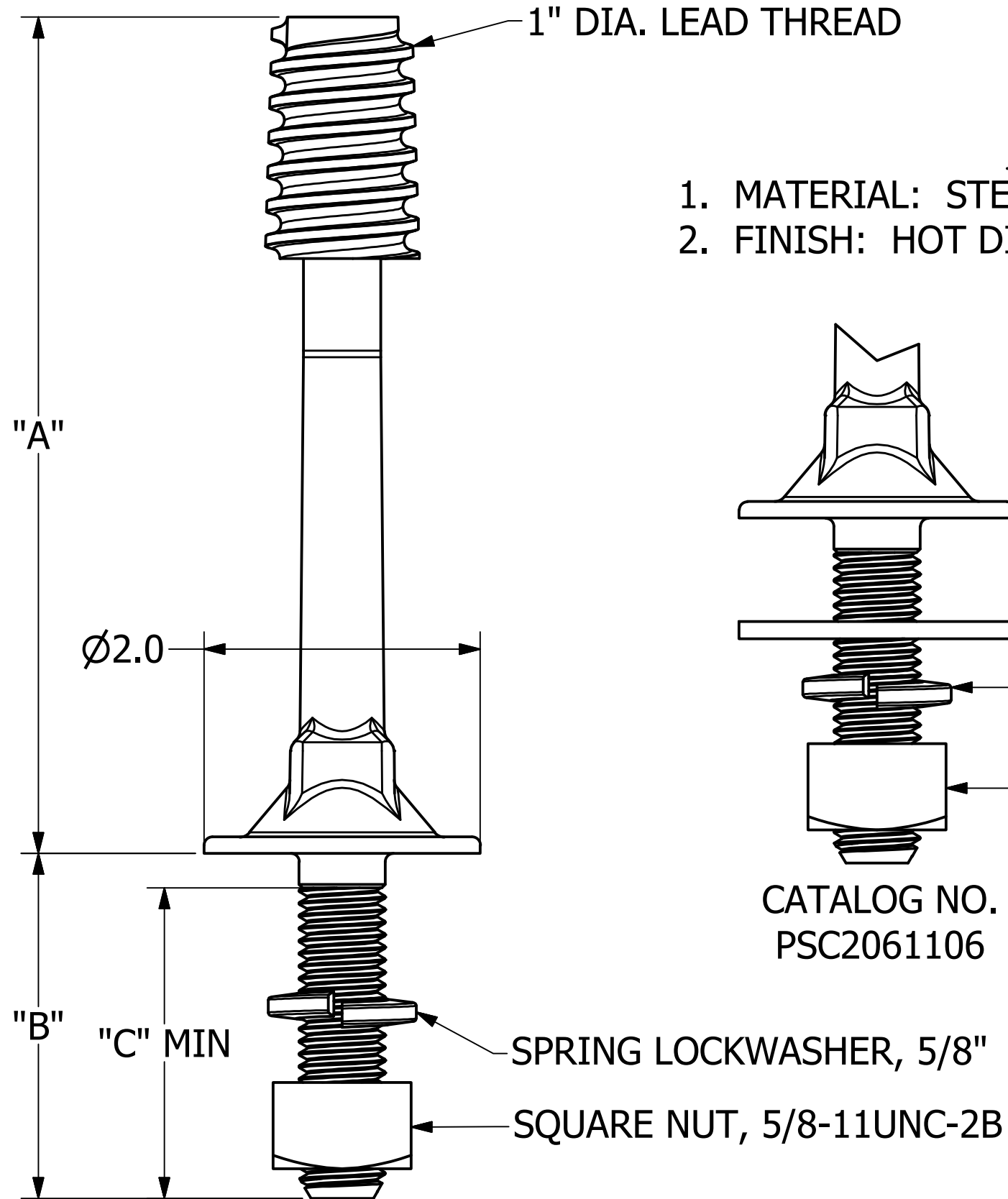

- NOTES -

1. MATERIAL: STEEL
2. FINISH: HOT DIP GALVANIZED PER ASTM A153 (LATEST REV)

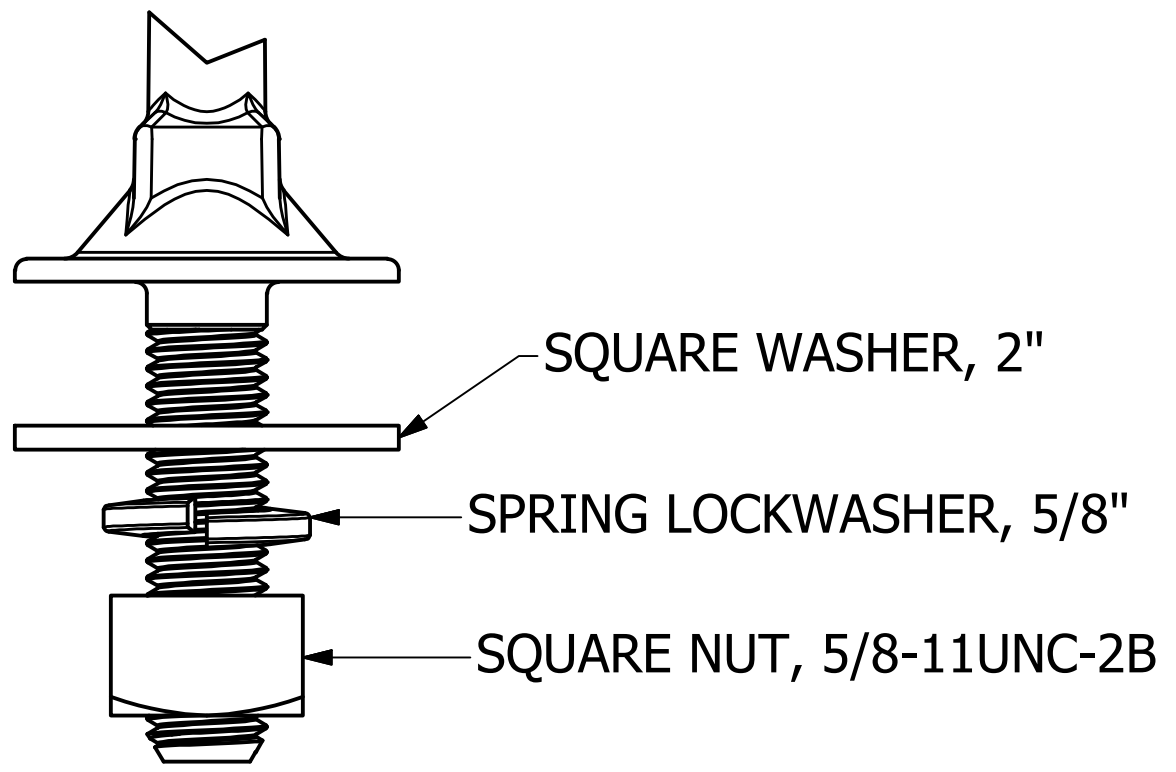

CATALOG NO.
PSC2061106

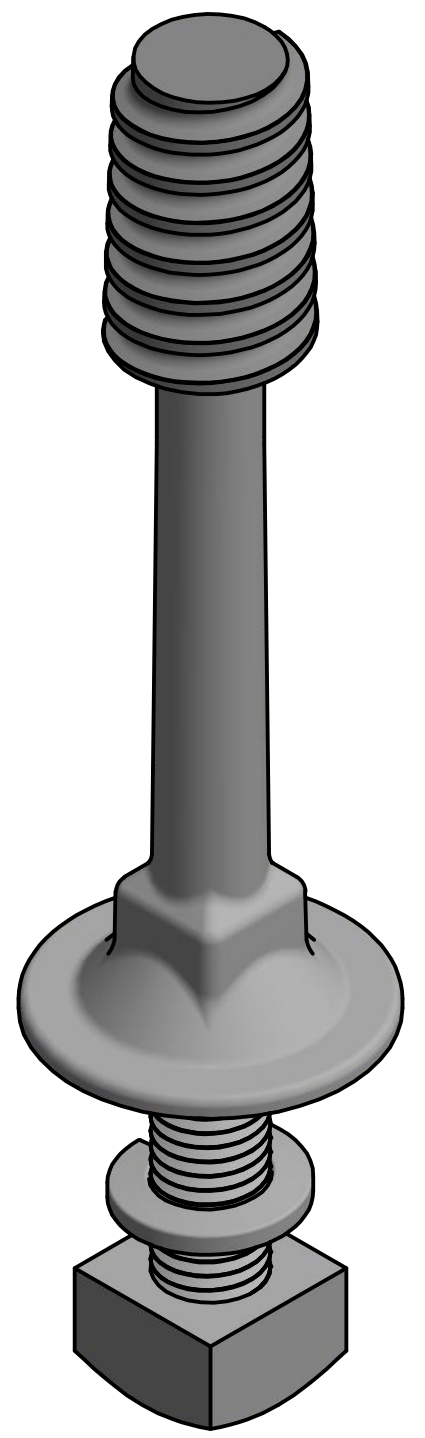

CHANCE [®]	HUBBELL [®] HUBBELL POWER SYSTEMS, INC. <small>POWER SYSTEMS, INC.</small>		
	TITLE FORGED L.V. STEEL PIN 1" LEAD THREAD, 5/8" DIA. SHANK		
CONFIDENTIAL: THIS DRAWING AND ITS CONTENTS ARE CONFIDENTIAL AND THE EXCLUSIVE PROPERTY OF HUBBELL POWER SYSTEMS. NO PUBLICATION, DISTRIBUTION, OR COPIES MAY BE MADE WITHOUT THE WRITTEN CONSENT OF HUBBELL POWER SYSTEMS. HUBBELL POWER SYSTEMS UNPUBLISHED ALL RIGHTS RESERVED UNDER THE COPYRIGHT LAWS.	SIZE B	CAT / PART / ASSY NO. SEE CHART	DWG NO. SA887
DO NOT SCALE THIS DRAWING	DRN BY HINKLE	DATE 04/19/17	REV A SHEET 1 OF 1