

MANUFACTURER'S IDENTIFICATION

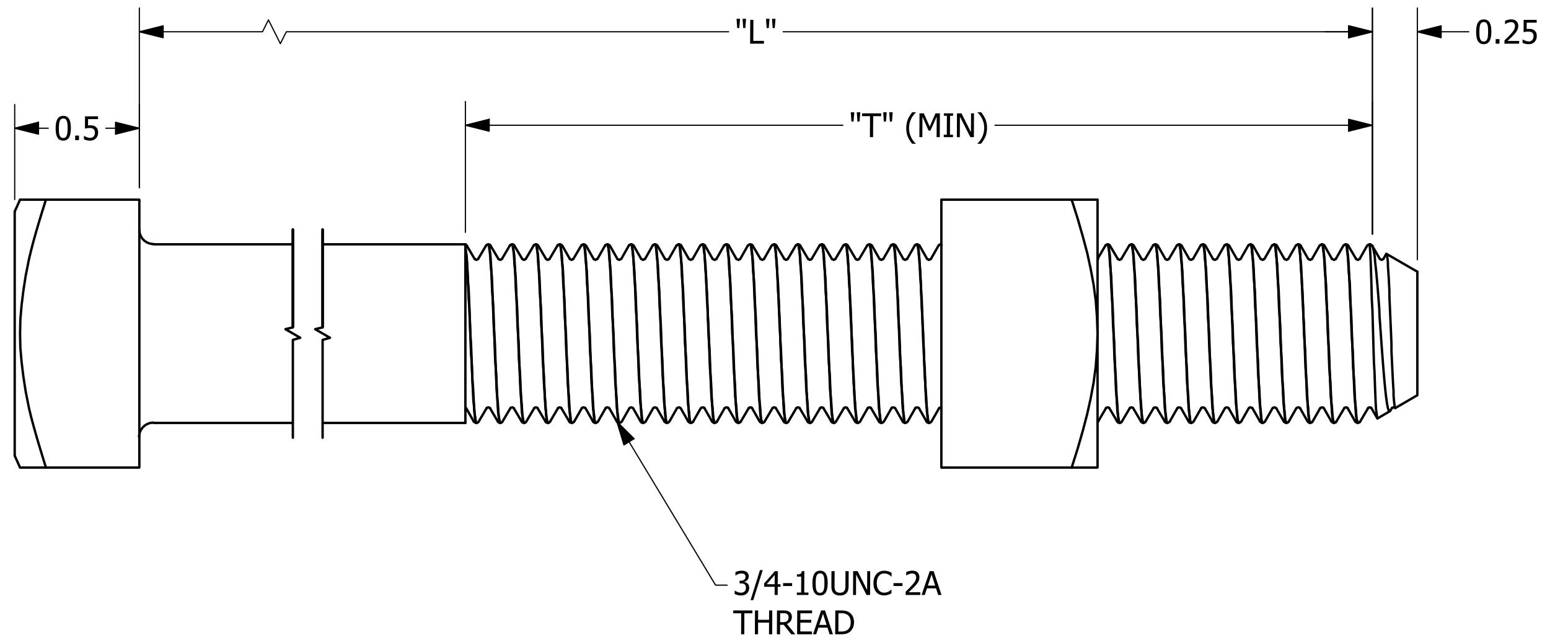
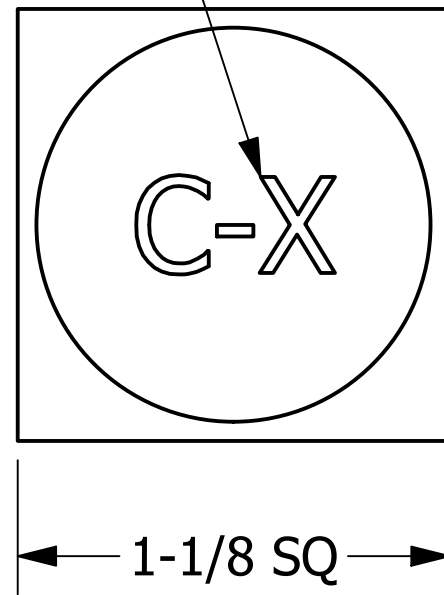

CATALOG NUMBER	USA PART NO.	"L"	"T"
PS8902		2	1.75
PS8903		3	1.75
PS8906		6	4
DF4B7		7	4
8908	8908USA	8	4
8910	8910USA	10	6
8912	8912USA	12	6
8914	8914USA	14	6
8916	8916USA	16	6
8918	8918USA	18	6
8920	8920USA	20	6
8922		22	6
8924		24	6
8926		26	6
8928		28	6
8930		30	8
8932		32	8
PS8934		34	8
PS8936		36	8

-NOTES-

1. MATERIAL: STEEL
2. FINISH: HOT DIP GALVANIZED PER ASTM A153
3. STRENGTH AND DIMENSIONS PER ANSI/IEEE C135.1 INCLUDING THE FOLLOWING:
- MINIMUM ASSEMBLY TENSILE STRENGTH 18,350 LBS
4. CATALOG NUMBERS WITH A "USA" SUFFIX HAVE ALL COMPONENTS MELTED AND MANUFACTURED IN THE USA.

CHANCE [®]	HUBBELL POWER SYSTEMS, INC.	
	TITLE BOLTS, MACHINE 3/4"	
CONFIDENTIAL: THIS DRAWING AND ITS CONTENTS ARE CONFIDENTIAL AND THE EXCLUSIVE PROPERTY OF HUBBELL POWER SYSTEMS. NO PUBLICATION, DISTRIBUTION, OR COPIES MAY BE MADE WITHOUT THE WRITTEN CONSENT OF HUBBELL POWER SYSTEMS. HUBBELL POWER SYSTEMS UNPUBLISHED ALL RIGHTS RESERVED UNDER THE COPYRIGHT LAWS.	SIZE C	CAT / PART / ASSY NO. SEE CHART
DO NOT SCALE THIS DRAWING	DRN BY HOEK	DWG NO. SA8908
		REV G
	DATE 10/23/20	SHEET 1 OF 1