

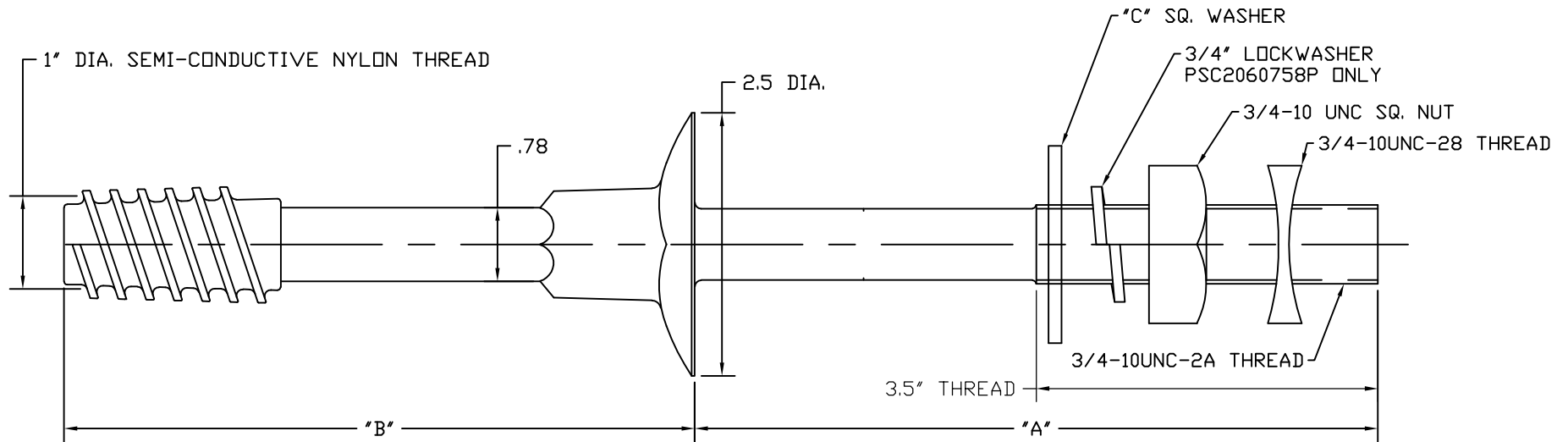

-NOTES-

1. MATERIAL: STEEL
2. FINISH: HOT DIP GALVANIZED PER ASTM A153 (LATEST REVISION).



CATALOG NO.	"A"	"B"	"C"
PS890P	6.5"	6.0"	2.25" X 2.25" X 3/16"
T2060269P	8.0"	6.0"	2.25" X 2.25" X 3/16"
PSC2060710	7.5"	6.0"	2.25" X 2.25" X 3/16"
PSC2060758P	5.5"	6.0"	2.25" X 2.25" X 3/16"

CHANCE TOLERANCE CHART		 HUBBELL POWER SYSTEMS	
<small>CONFIDENTIAL: THIS DRAWING AND ITS CONTENTS ARE CONFIDENTIAL AND THE EXCLUSIVE PROPERTY OF HUBBELL POWER SYSTEMS. NO PUBLICATION, DISTRIBUTION OR COPIES MAY BE MADE WITHOUT THE WRITTEN CONSENT OF HUBBELL POWER SYSTEMS. HUBBELL POWER SYSTEMS UNPUBLISHED ALL RIGHTS RESERVED UNDER THE COPYRIGHT LAWS.</small>		TITLE NYLON THREAD FORGED STEEL PIN ASSY.	
SIZE SB SA890P	DWG NO. SEE CHART	CAT / PART / ASSY NO. SEE CHART	REV J
DO NOT SCALE THIS DRAWING	DRN BY WILSON	DATE 6/20/13	SHEET 01 OF 01