

MANUFACTURER'S IDENTIFICATION

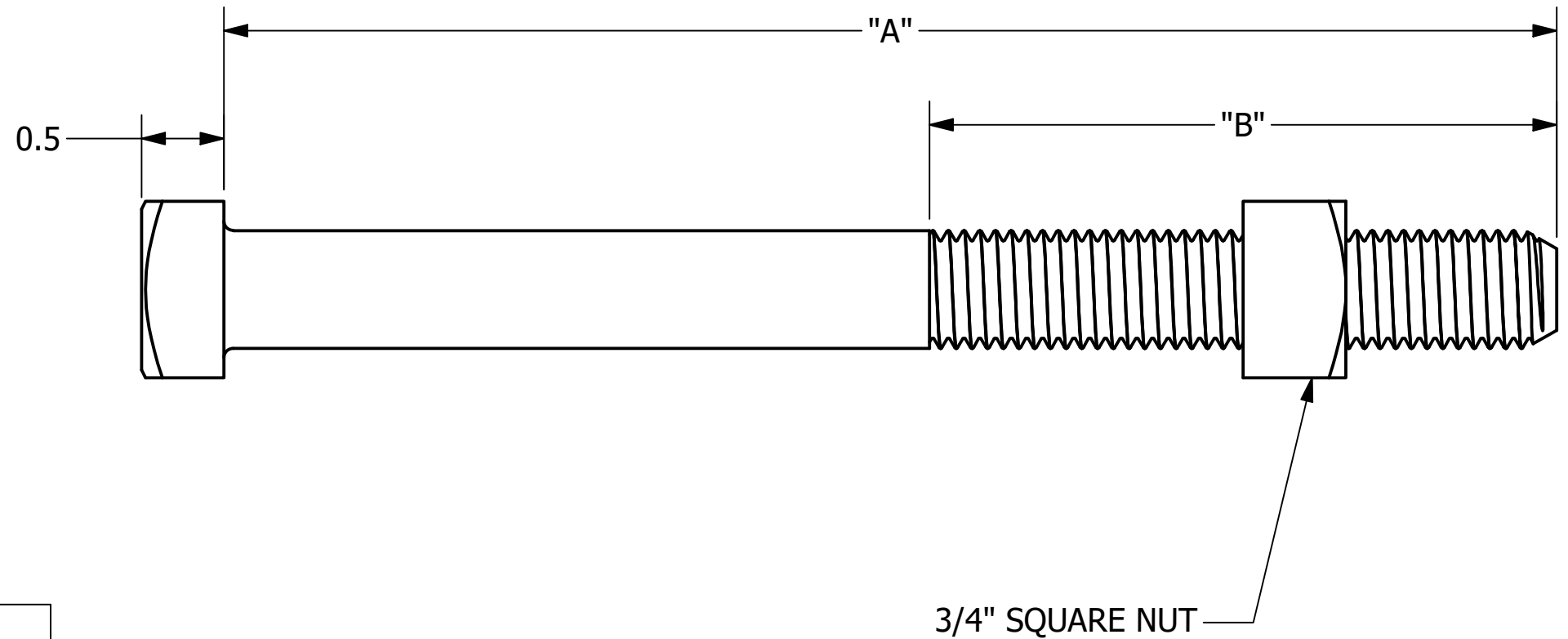
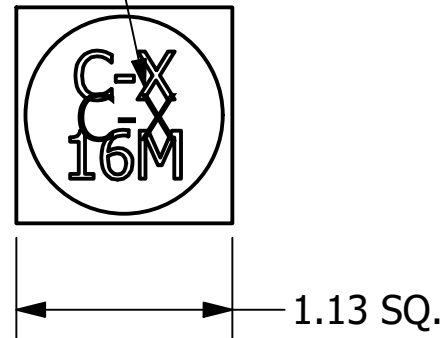

CATALOG NUMBER	"A"	"B"
PS8902TDG	2	1.5
PS8906TDG	6	2.5
DF4B7TDG	7	4
8908TDG	8	4
8910TDG	10	6
8912TDG	12	6
8914TDG	14	6
8916TDG	16	6
8918TDG	18	6
8920TDG	20	6
8924TDG	24	6
8926TDG	26	6
8930TDG	30	8

- NOTES -

- MATERIAL: STEEL. STRENGTH AND DIMENSIONS PER IEEE C135.1 INCLUDING THE FOLLOWING:
  - MINIMUM ASSEMBLY TENSILE STRENGTH OF 18,350 LBS.
- FINISH: ARMORGALV® THERMO-DIFFUSION GALVANIZING PER ASTM 1059.

<b>CHANCE</b> ®	<b>HUBBELL</b> ® POWER SYSTEMS, INC.		
	TITLE <b>3/4" MACHINE OR CROSSARM BOLT</b>		
CONFIDENTIAL: THIS DRAWING AND ITS CONTENTS ARE CONFIDENTIAL AND THE EXCLUSIVE PROPERTY OF HUBBELL POWER SYSTEMS. NO PUBLICATION, DISTRIBUTION, OR COPIES MAY BE MADE WITHOUT THE WRITTEN CONSENT OF HUBBELL POWER SYSTEMS. HUBBELL POWER SYSTEMS UNPUBLISHED ALL RIGHTS RESERVED UNDER THE COPYRIGHT LAWS.	SIZE <b>B</b>	CAT / PART / ASSY NO. <b>SEE TABLE</b>	DWG NO. <b>SA8912TDG</b>
DO NOT SCALE THIS DRAWING	DRN BY TOLIVER	DATE 12/12/22	REV <b>C</b> SHEET 1 OF 1