

CATALOG NUMBER  
C11MWC22B1L

-NOTES-

1. ASSEMBLED COMPLETE AS SHOWN.
2. MATERIAL: ALUMINUM (RACK BODY). GALVANIZED STEEL HARDWARE.
3. ASSEMBLIES SUPPLIED WITH 3/4" X 2-1/2" HIGH STRENGTH (GRADE 5) BOLTS (QTY. 6) FOR USE WITH ALL TRANSFORMER LUGS (HEX NUTS AND LOCKWASHERS INCLUDED).
4. ROTATING ONE TRANSFORMER MOUNTING EAR PAIR ALLOWS MOUNTING OF TRANSFORMERS WITH 15" LUG SPACING.

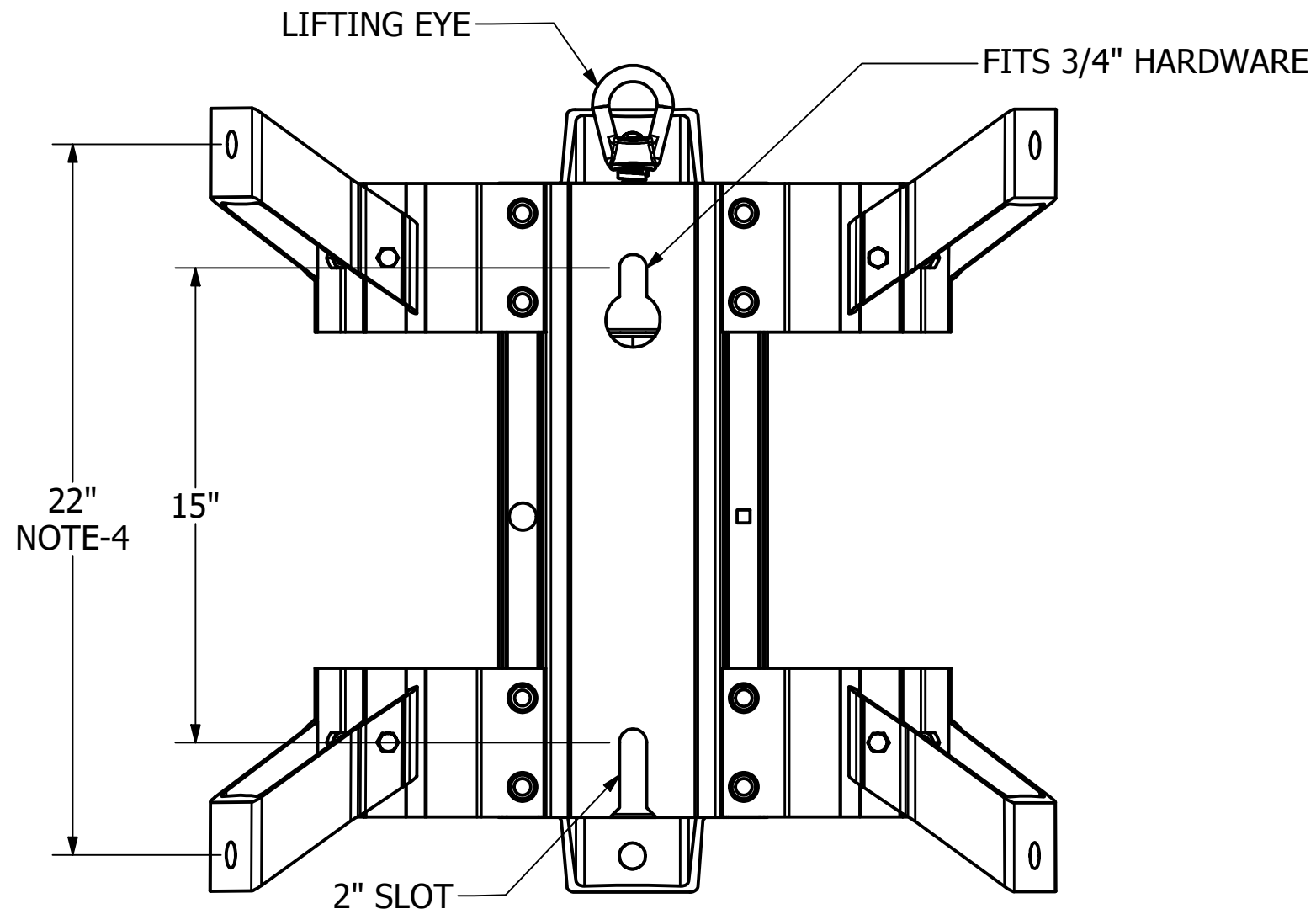

<b>CHANCE</b> <sup>®</sup>		<b>HUBBELL</b> <sup>®</sup> HUBBELL POWER SYSTEMS, INC. POWER SYSTEMS, INC.	
CONFIDENTIAL: THIS DRAWING AND ITS CONTENTS ARE CONFIDENTIAL AND THE EXCLUSIVE PROPERTY OF HUBBELL POWER SYSTEMS. NO PUBLICATION, DISTRIBUTION, OR COPIES MAY BE MADE WITHOUT THE WRITTEN CONSENT OF HUBBELL POWER SYSTEMS. HUBBELL POWER SYSTEMS UNPUBLISHED ALL RIGHTS RESERVED UNDER THE COPYRIGHT LAWS.		TITLE <b>WING RACK WITH LIFTING EYE</b>	
SIZE <b>B</b>	CAT / PART / ASSY NO. <b>C11MWC22B1L</b>	DWG NO. <b>SAC11MWC22B1L</b>	REV <b>C</b>
DO NOT SCALE THIS DRAWING	DRN BY TOLIVER	DATE 12/11/19	SHEET 1 OF 1