

-NOTES-

1. ASSEMBLED COMPLETE AS SHOWN.
2. MATERIAL: ALUMINUM (RACK BODY), GALVANIZED STEEL (HARDWARE).
3. ASSEMBLIES SUPPLIED WITH 5/8" X 2" SQUARE HEAD MACHINE BOLTS (QTY. 6), (HEX NUTS AND LOCKWASHERS INCLUDED).

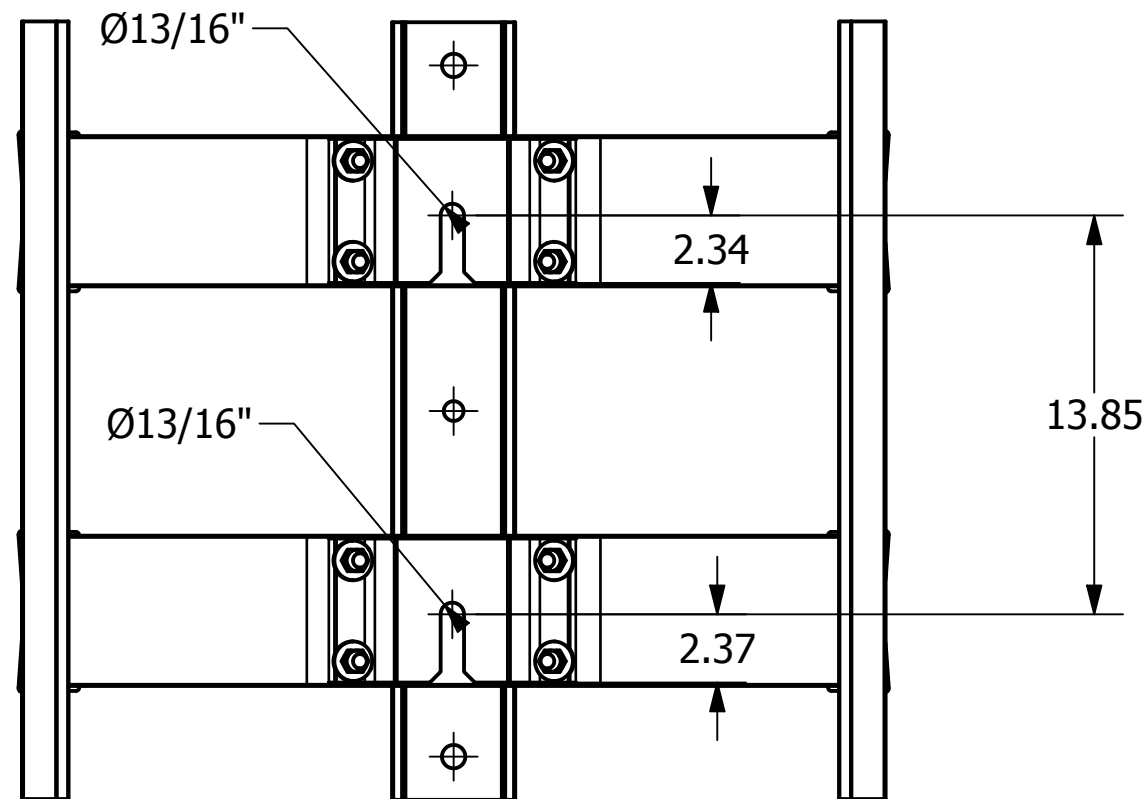
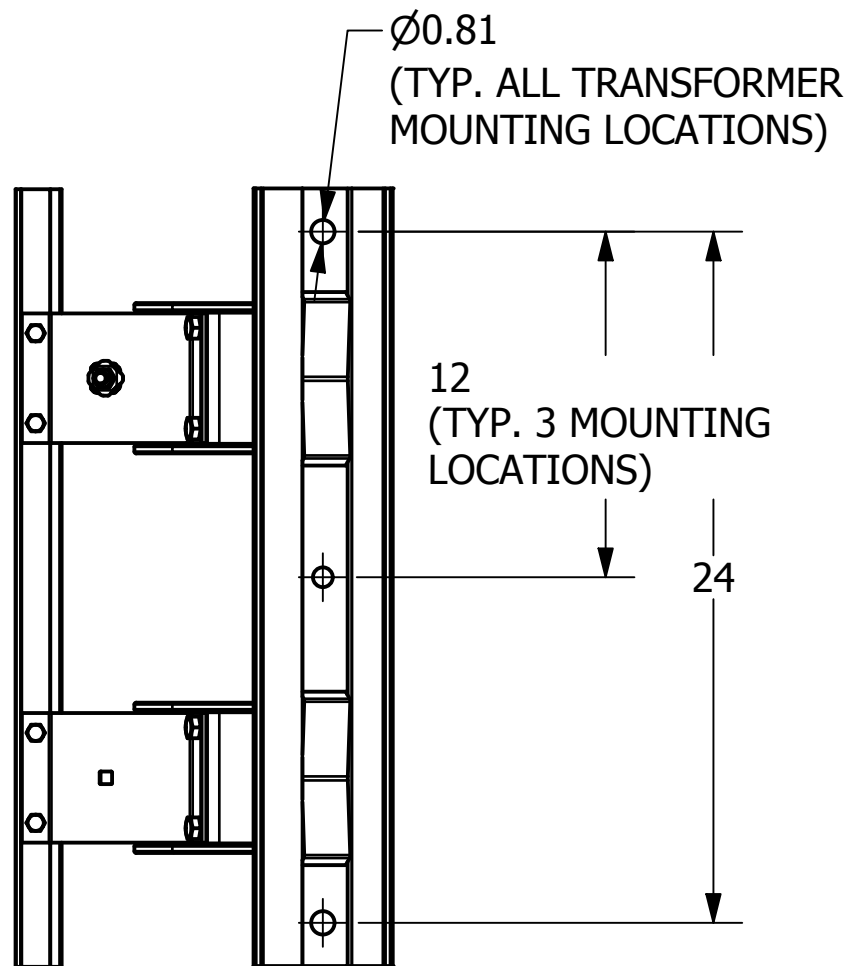
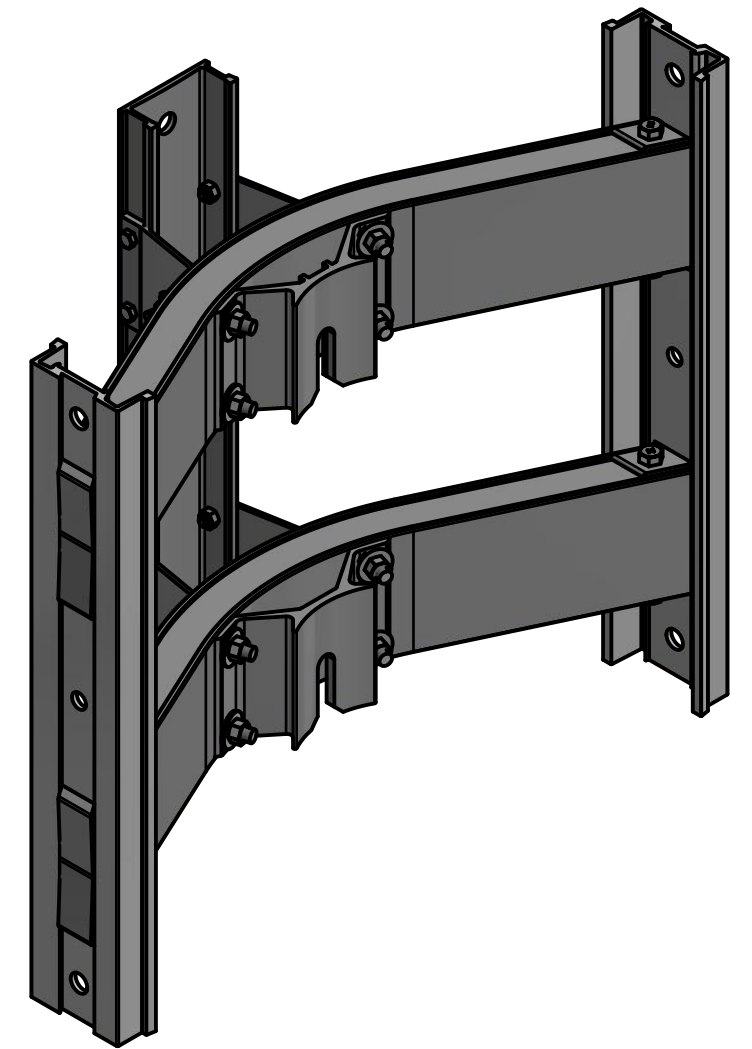
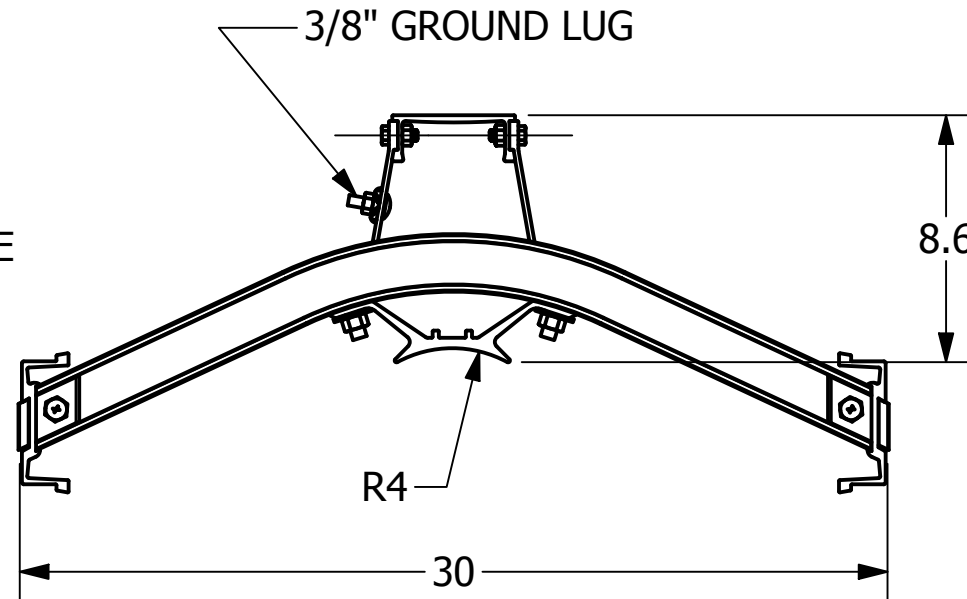

CATALOG NUMBER
CA12MW30A

CHANCE®



HUBBELL POWER SYSTEMS, INC.

TITLE
WING CLUSTER MOUNT

CONFIDENTIAL: THIS DRAWING AND ITS CONTENTS ARE CONFIDENTIAL AND THE EXCLUSIVE PROPERTY OF HUBBELL POWER SYSTEMS. NO PUBLICATION, DISTRIBUTION, OR COPIES MAY BE MADE WITHOUT THE WRITTEN CONSENT OF HUBBELL POWER SYSTEMS. HUBBELL POWER SYSTEMS UNPUBLISHED ALL RIGHTS RESERVED UNDER THE COPYRIGHT LAWS.

| | | | |
|---------------------------|--|------------------------------|-----------------|
| SIZE B | CAT / PART / ASSY NO. SAC12MW30A | DWG NO. SAC12MW30A | REV A |
| DO NOT SCALE THIS DRAWING | DRN BY OJS | DATE 2/5/2020 | SHEET 1 OF 1 |