

CATALOG NUMBER: C1HCAC18

NOTES:

- 1.) MATERIAL: ALUMINUM.
- 2.) ASSEMBLED COMPLETE AS SHOWN.

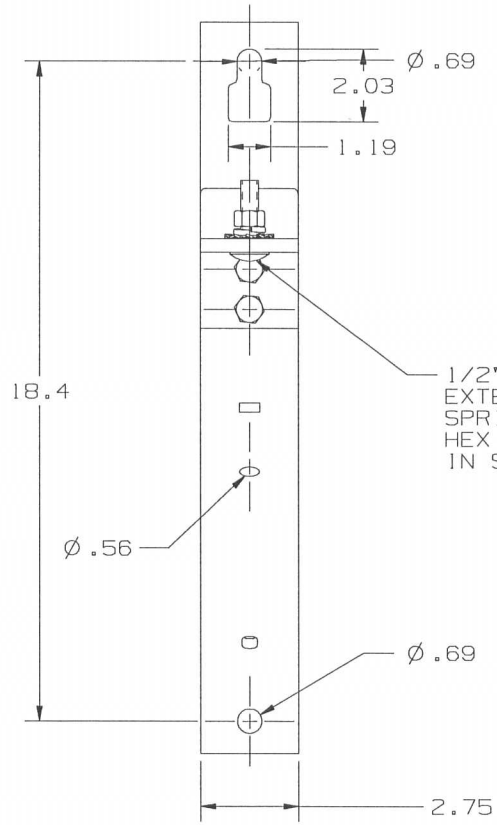

LATEST EC NO:	REV.	DATE	CHANGED BY	RESP ENGINEER
---	-	-----	---	---
			DO NOT SCALE THIS DWG	THIRD ANGLE PROJECTION 150 DUAL DIMENSIONS IN=INCH, MM=MILLIMETER

DRN BY:	DATE	TITLE:	SIZE
JJL	08-17-11	SINGLE PHASE APPARATUS BRACKET	D

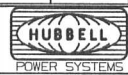

CHANCE®



DWG NO: SAC1HCA-C-18

CONFIDENTIAL: THIS DRAWING AND ITS CONTENTS ARE CONFIDENTIAL AND THE EXCLUSIVE PROPERTY OF HUBBELL / A.B. CHANCE COMPANY. NO PUBLICATION, DISTRIBUTION OR COPIES MAY BE MADE WITHOUT WRITTEN CONSENT BY HUBBELL / A.B. CHANCE COMPANY. © 2001 HUBBELL/A.B. CHANCE. UNPUBLISHED - ALL RIGHTS RESERVED UNDER THE COPYRIGHT LAWS