

1/2 X 2" CARRIAGE BOLT WITH ROUND WASHER, SPLIT RING LOCKWASHER, AND HEX NUT.

3/8 X 5" CARRIAGE BOLTS WITH HEX NUTS AND ROUND WASHERS

HOLE PATTERN OF STRAP

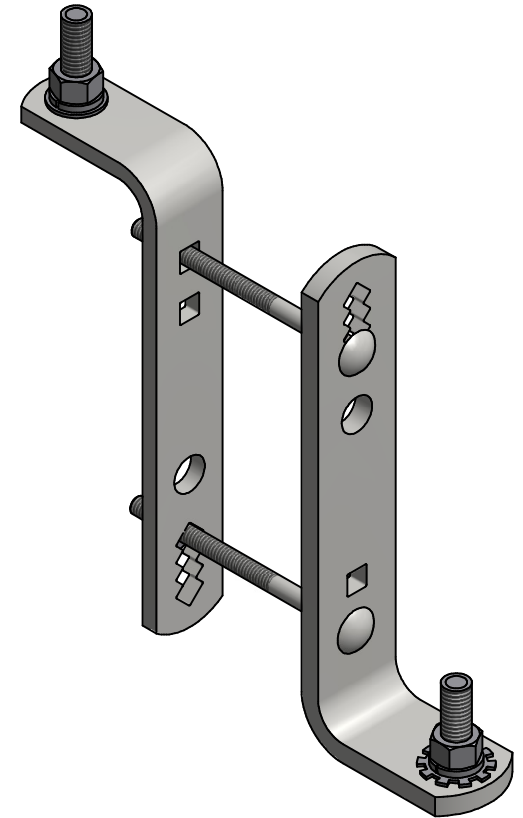
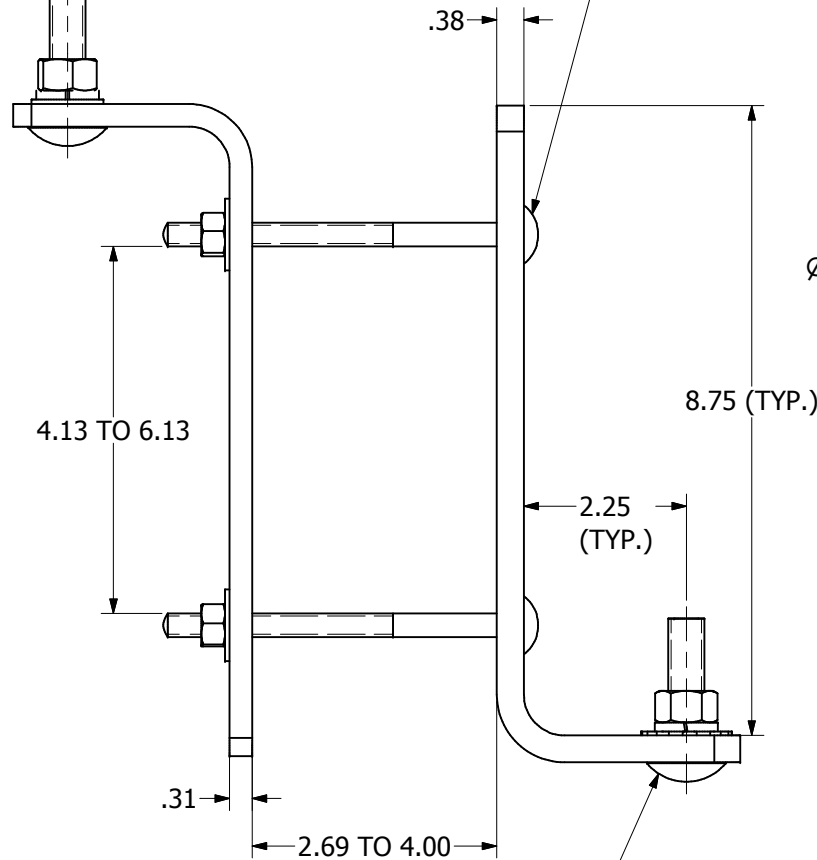

CATALOG NUMBER: C2060663

NOTE

1. MATERIAL: STEEL, HOT DIP GALVANIZED PER ASTM A153 (LATEST REVISION).

1/2 X 2" CARRIAGE BOLT WITH INT./EXT. TOOTH LOCKWASHER, SPLIT RING LOCKWASHER, AND HEX NUT.

<p>CHANCE[®]</p> <p><small>CONFIDENTIAL: THIS DRAWING AND ITS CONTENTS ARE CONFIDENTIAL AND THE EXCLUSIVE PROPERTY OF HUBBELL POWER SYSTEMS. NO PUBLICATION, DISTRIBUTION, OR COPIES MAY BE MADE WITHOUT THE WRITTEN CONSENT OF HUBBELL POWER SYSTEMS. HUBBELL POWER SYSTEMS UNPUBLISHED ALL RIGHTS RESERVED UNDER THE COPYRIGHT LAWS.</small></p>	<p>HUBBELL[®] POWER SYSTEMS, INC.</p>		<p>HUBBELL POWER SYSTEMS, INC.</p>	
	<p>TITLE</p> <p>BRACKET, CROSSARM ASSY.</p>			
<p>DO NOT SCALE THIS DRAWING</p>	<p>SIZE</p> <p>C</p>	<p>CAT / PART / ASSY NO.</p> <p>C206-0663</p>	<p>DWG NO.</p> <p>SAC2060663</p>	<p>REV</p> <p>A</p>
<p>DRN BY WITTEN</p>		<p>DATE 10/23/15</p>	<p>SHEET 1 OF 1</p>	