

- NOTES -

1. MATERIAL: ALUMINUM (RACK BODY) GALVANIZED STEEL (HARDWARE).
2. ASSEMBLED COMPLETE AS SHOWN.

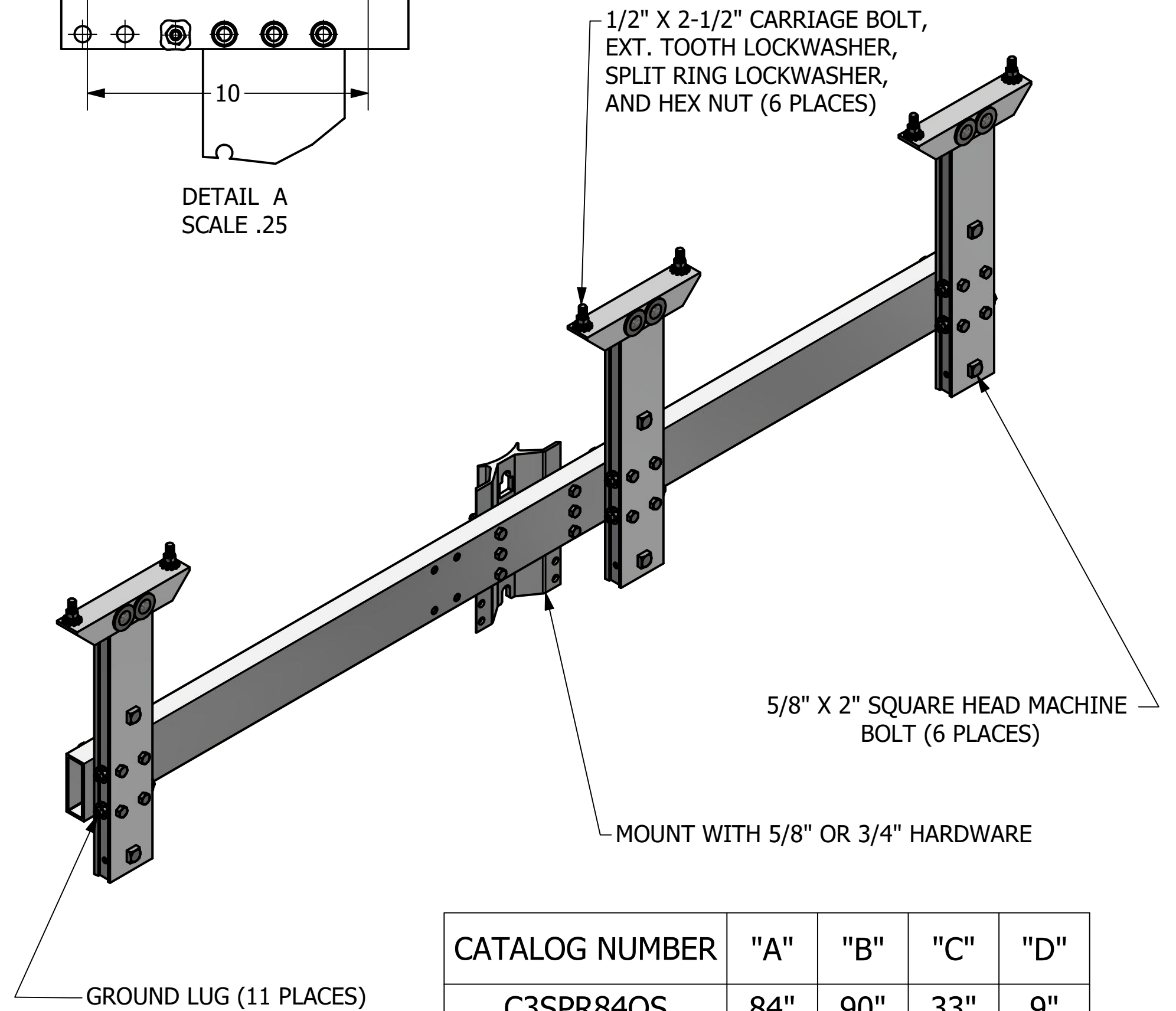
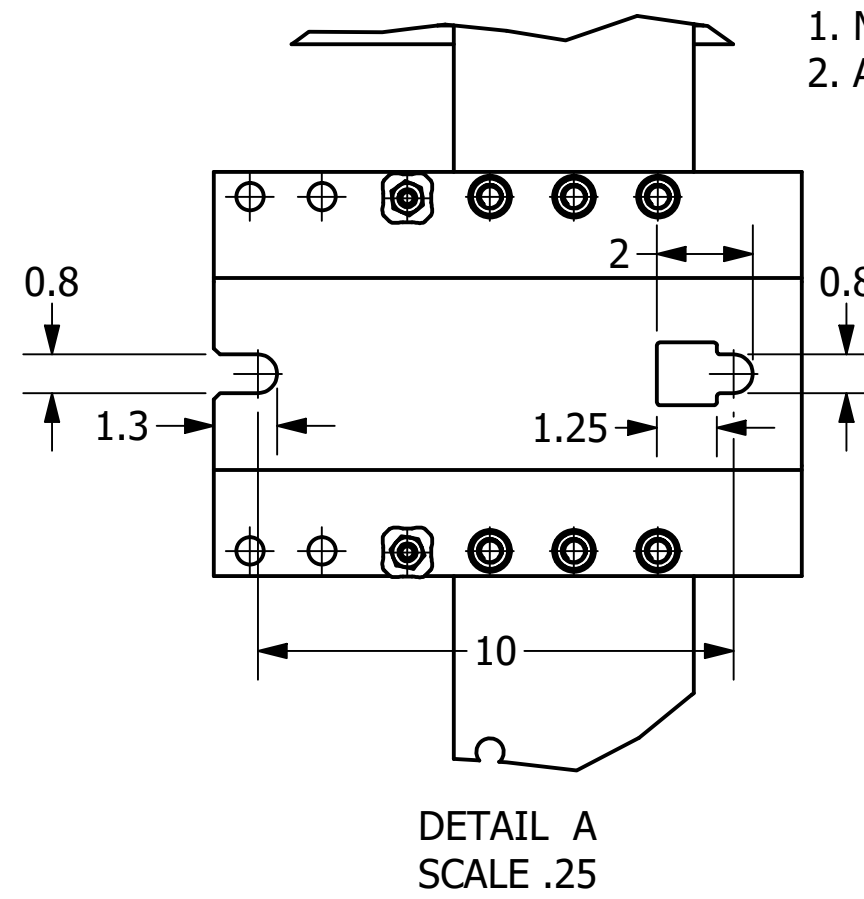
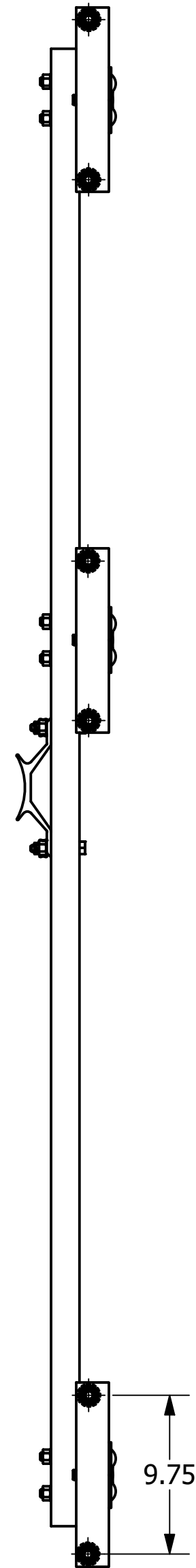
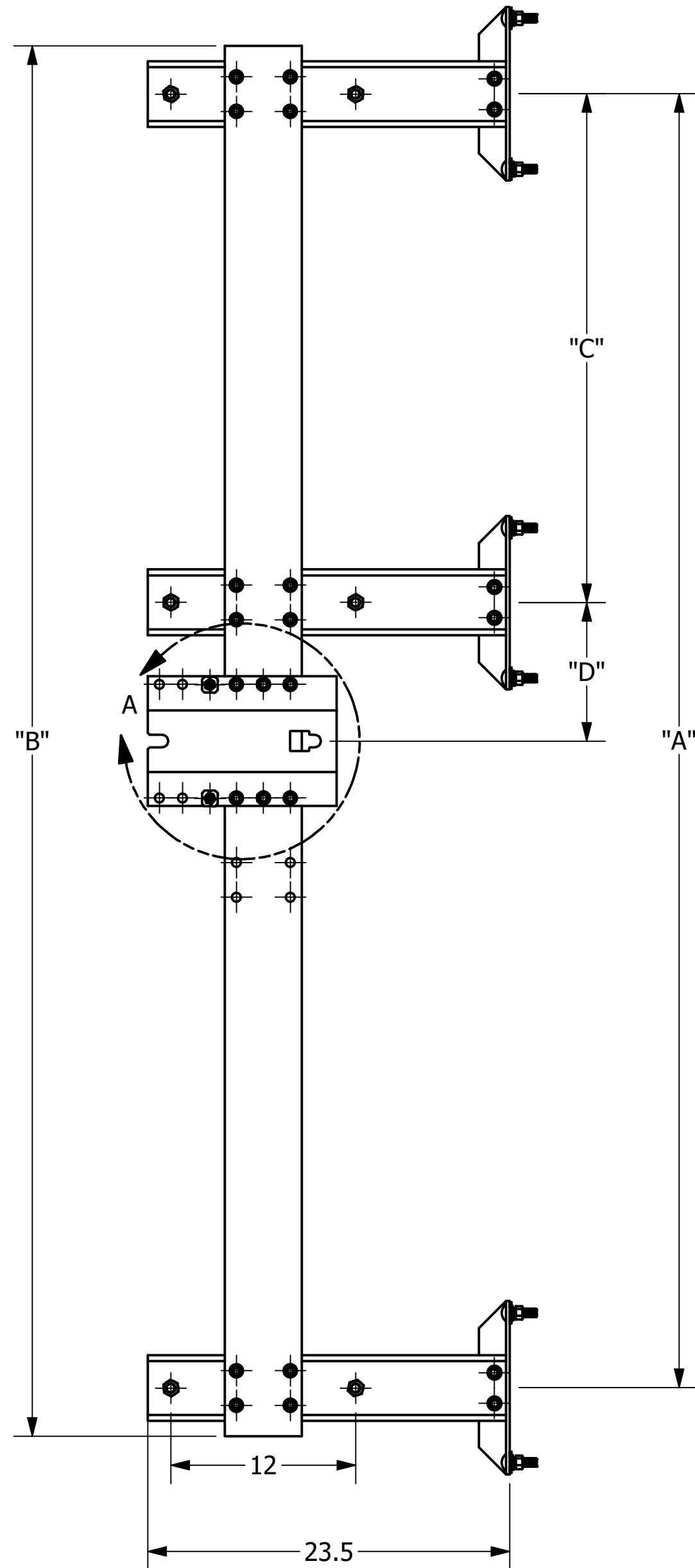

CATALOG NUMBER	"A"	"B"	"C"	"D"
C3SPR84OS	84"	90"	33"	9"
C3SPR120OS	114"	120"	36"	21"

<h1>CHANCE<sup>®</sup></h1>				
	<b>MOUNT, RECLOSER</b>			
CONFIDENTIAL: THIS DRAWING AND ITS CONTENTS ARE CONFIDENTIAL AND THE EXCLUSIVE PROPERTY OF HUBBELL POWER SYSTEMS. NO PUBLICATION, DISTRIBUTION, OR COPIES MAY BE MADE WITHOUT THE WRITTEN CONSENT OF HUBBELL POWER SYSTEMS. HUBBELL POWER SYSTEMS UNPUBLISHED ALL RIGHTS RESERVED UNDER THE COPYRIGHT LAWS.	SIZE <b>C</b>	CAT / PART / ASSY NO. <b>SEE TABLE</b>	DWG NO. <b>SAC3SPR84OS</b>	REV <b>A</b>
DO NOT SCALE THIS DRAWING	DRN BY TOLIVER	DATE 2/26/20	SHEET 1 OF 1	