

CATALOG NUMBER C4000919

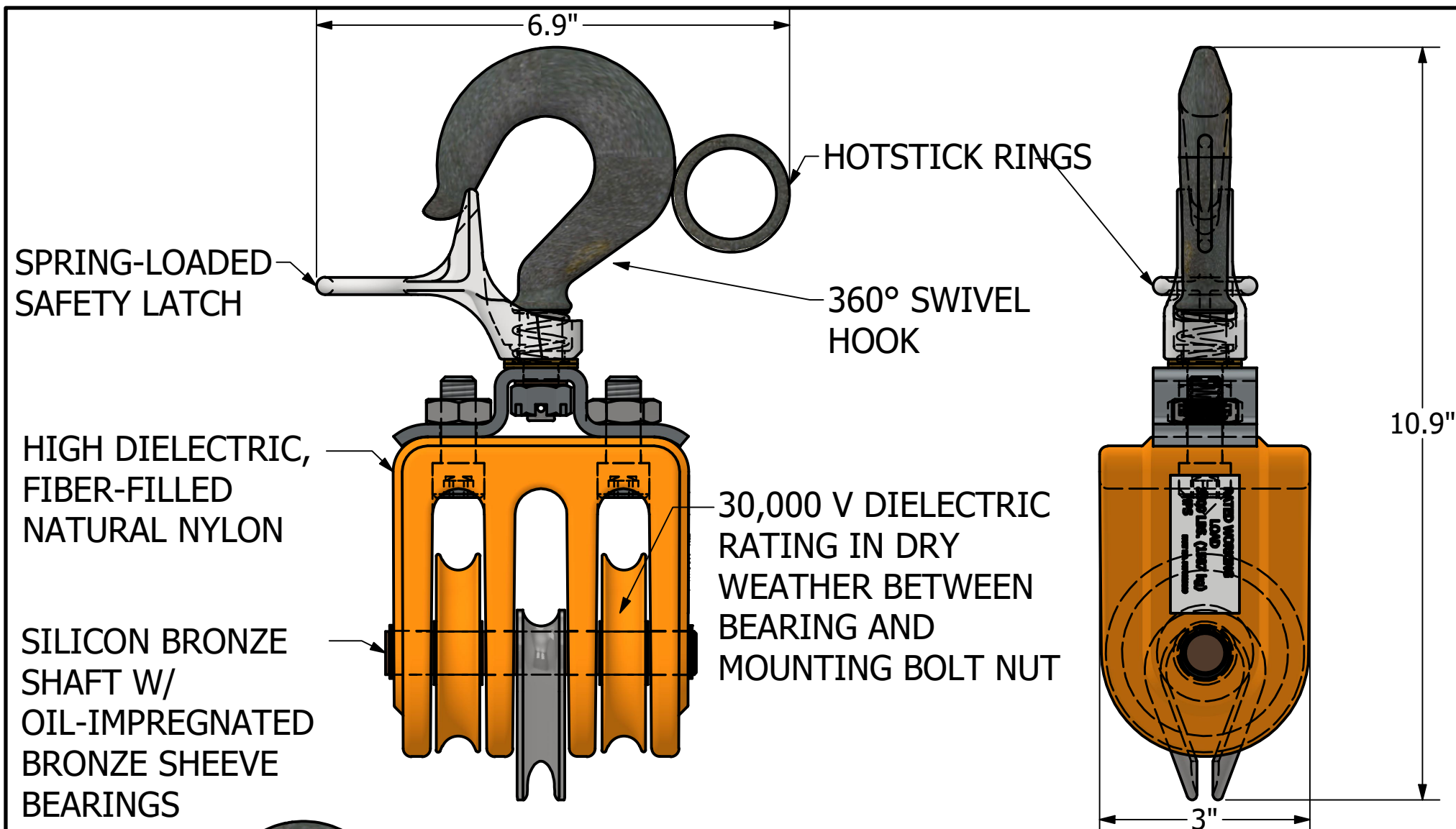

MAX LOAD RATING	3500 lbs (1587 kg)
WEIGHT	3.3 lbs (1.5 kg)
STYLE	DOUBLE BLOCK W BECKET
MAX ROPE DIAMETER	1/2"

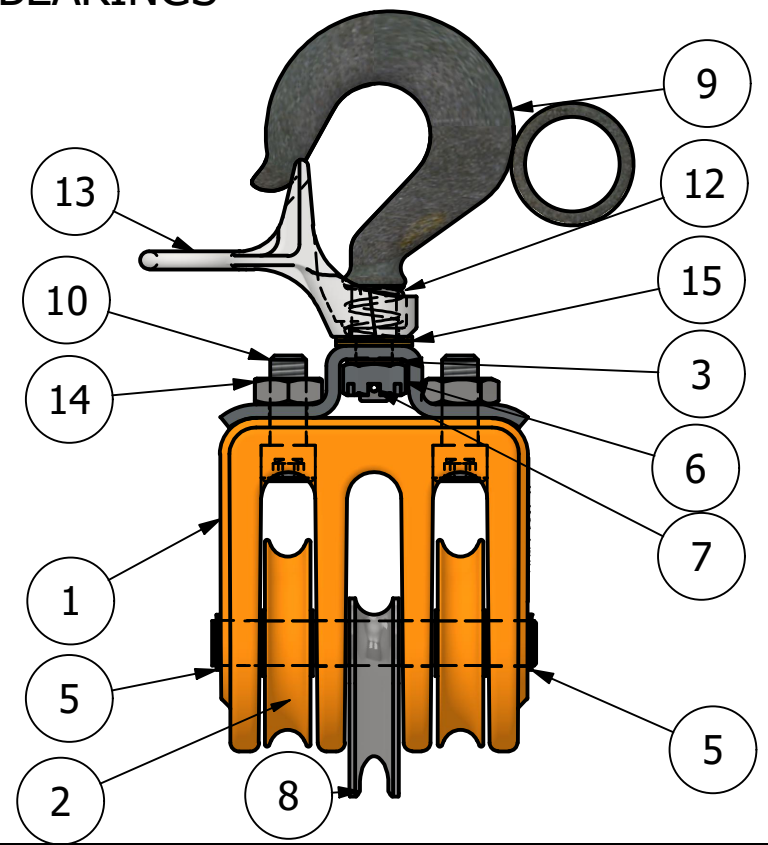

REPAIR PARTS LIST		
ITEM	PART NUMBER	DESCRIPTION
1	P4000900P	INSULATED BLOCK (TRIPLE)
2	P4000901P	SHEAVE
3	P4000902P	BEARING
5	P4000905P	TRUARC RING
6	059386P	SLOTTED NUT
7	058865P	ROLL PIN .093 X .750
8	P4000908P	THIMBLE
9	E4000910P	HOOK ASSEMBLY
10	P0011349P	SKT HD BOLT 1/2 X 1-1/4
12	019563P	SPRING
13	P4000570P	SAFETY LATCH
14	058941P	HEX NUT, 1/2-13", SS
15	056646P	WASHER FLAT BRASS

CHANCE® HUBBELL POWER SYSTEMS, INC.

CONFIDENTIAL: THIS DRAWING AND ITS CONTENTS ARE CONFIDENTIAL AND THE EXCLUSIVE PROPERTY OF HUBBELL POWER SYSTEMS. NO PUBLICATION, DISTRIBUTION, OR COPIES MAY BE MADE WITHOUT THE WRITTEN CONSENT OF HUBBELL POWER SYSTEMS. HUBBELL POWER SYSTEMS UNPUBLISHED ALL RIGHTS RESERVED UNDER THE COPYRIGHT LAWS.

TITLE: **INSULATED BLOCK ASSEMBLY W BECKET**

SIZE B	CAT / PART / ASSY NO. C4000919	DWG NO. SAC4000919	REV A
DO NOT SCALE THIS DRAWING	DRN BY ALJ	DATE 03/21/24	SHEET 1 OF 1