

NOTES:

- 1.) MATERIAL: EQUIPMENT MOUNT BODY, ALUMINUM HARDWARE, GALVANIZED STEEL.
- 2.) ASSEMBLED COMPLETE AS SHOWN.
- 3.) MOUNTS ON WOOD POLES WITH 5/8" THRU-BOLT AND 3 LAG SCREWS (NOT SUPPLIED WITH ASSEMBLY).

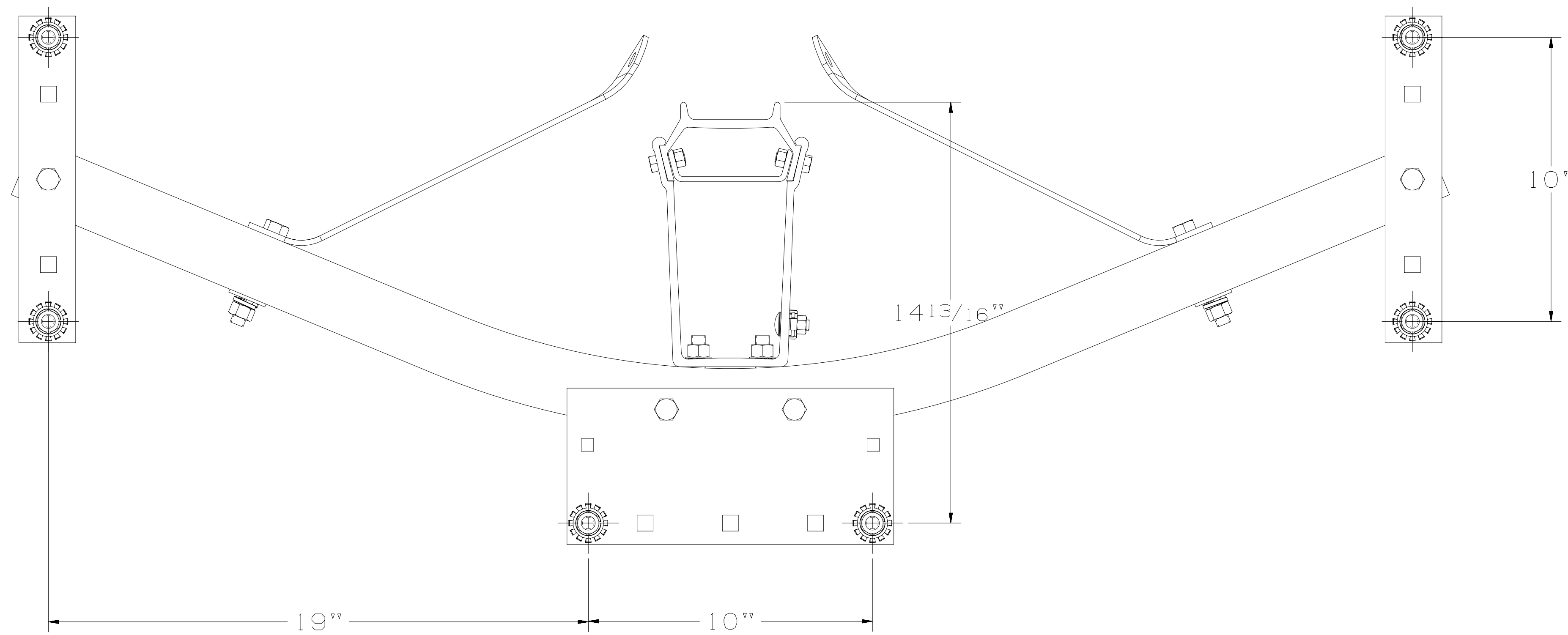

CATALOG NUMBER: CR3CA48

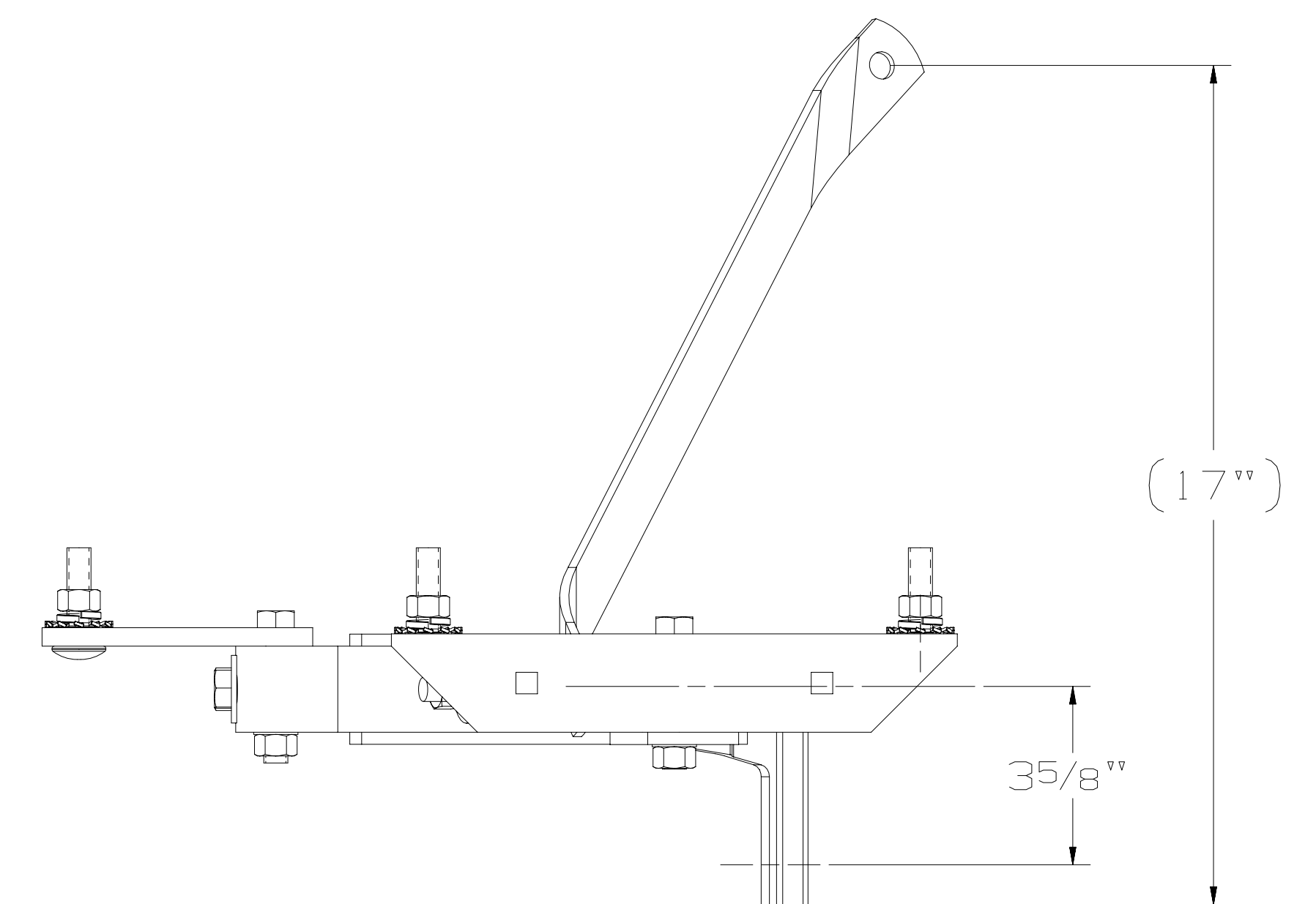
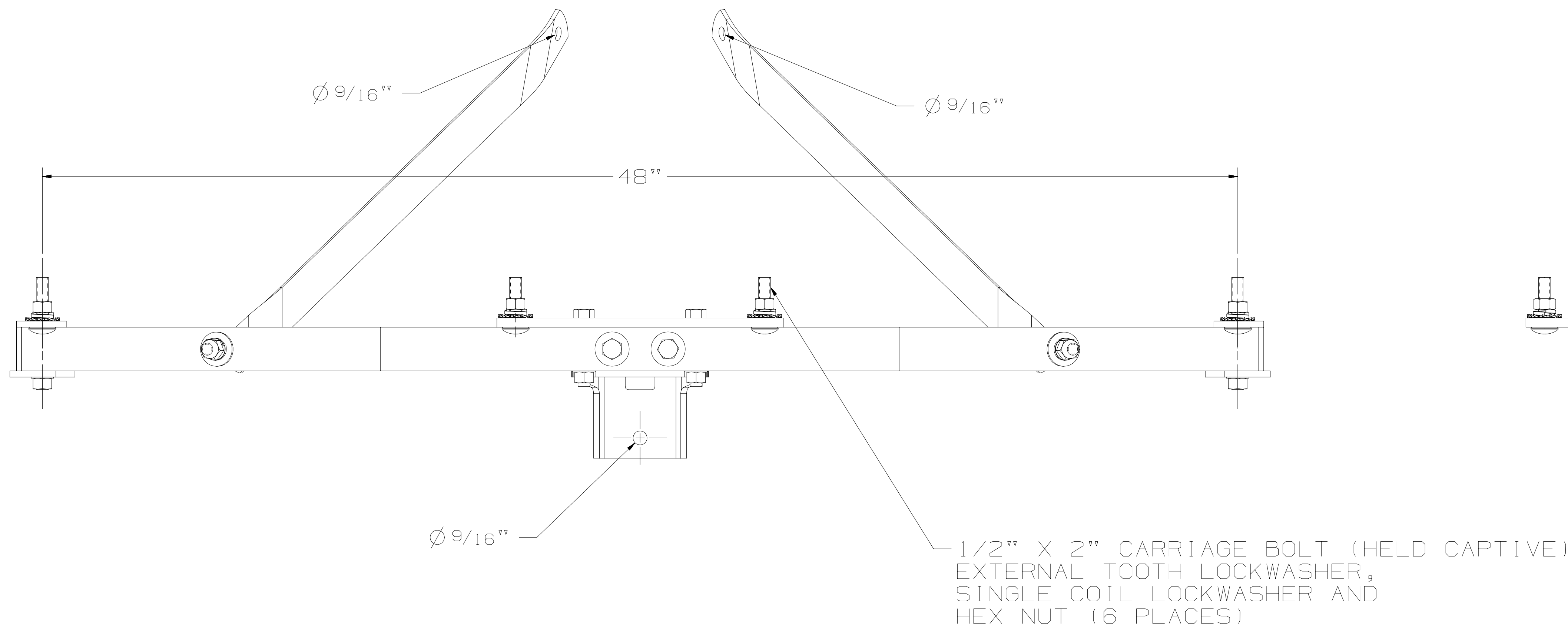

| | | | | | |
|---------------|----------|-----------------------------|-------|---|------------------------|
| LATEST EC NO: | | REV. | DATE | CHANGED BY | RESP ENGINEER |
| ----- | | A | ----- | ----- | ----- |
| | | | | DO NOT SCALE THIS DWG | THIRD ANGLE PROJECTION |
| | | | | 1:50 DUAL DIMENSIONS IN=INCH, MM=MILLIMETER | |
| DRN BY: | DATE | TITLE: | | | SIZE |
| JUL | 04-25-12 | CURVED TUBE EQUIPMENT MOUNT | | | D |
| | | | | | |
| | | DWG NO: | | SACR3CA-48 | |

CONFIDENTIAL: THIS DRAWING AND ITS CONTENTS ARE CONFIDENTIAL AND THE EXCLUSIVE PROPERTY OF HUBBELL POWER SYSTEMS, INC. NO PUBLICATION, DISTRIBUTION OR REPRODUCTION OF THIS DRAWING OR ANY PARTS THEREOF SHALL BE MADE WITHOUT THE WRITTEN CONSENT OF HUBBELL POWER SYSTEMS, INC. © 2012 HUBBELL POWER SYSTEMS. UNPUBLISHED. ALL RIGHTS RESERVED UNDER THE COPYRIGHT LAWS.