

1/2" X 2" CARRIAGE BOLT,  
 1/2" PUSH NUT  
 1/2" LOCKWASHER  
 1/2" HEX NUT

NOTES :

- 1.) MATERIAL: STEEL, GALVANIZED PER ASTM A153.
- 2.) ASSEMBLED COMPLETE AS SHOWN.

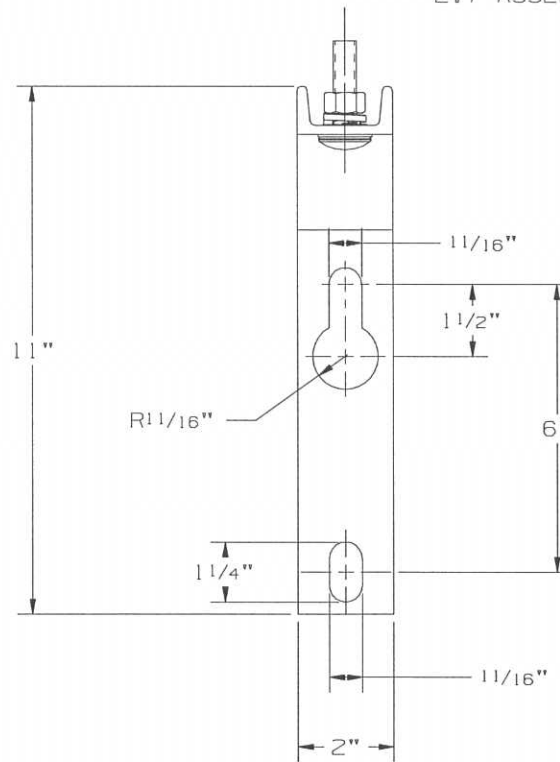

CATALOG NUMBER : DC162B2

LATEST EC NO:		REV.	DATE	CHANGED BY	RESP ENGINEER
---		-	-----	---	---
				DO NOT SCALE THIS DWG	THIRD ANGLE PROJECTION
				ISO DUAL DIMENSIONS IN-INCH, MM-MILLIMETER	
DRN BY:	DATE	TITLE:			SIZE
JUL	11-01-11	MOUNTING BRACKET			B
		DWG NO:		SADC162B	

CONFIDENTIAL: THIS DRAWING AND ITS CONTENTS ARE CONFIDENTIAL AND THE EXCLUSIVE PROPERTY OF HUBBELL / A.B. CHANCE COMPANY. NO PUBLICATION, DISTRIBUTION OR COPIES MAY BE MADE WITHOUT WRITTEN CONSENT BY HUBBELL / A.B. CHANCE COMPANY. © 2001 HUBBELL/A.B. CHANCE. UNPUBLISHED - ALL RIGHTS RESERVED UNDER THE COPYRIGHT LAWS