

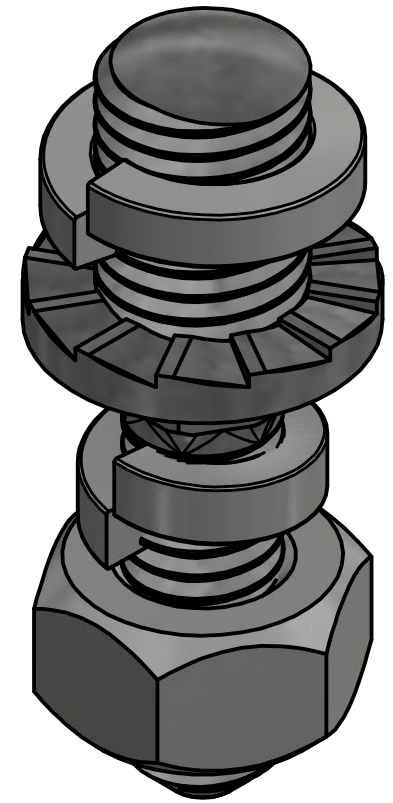

-NOTES-

1. MATERIAL: STEEL, HOT DIP GALVANIZED PER ASTM A153 (LATEST REVISION)

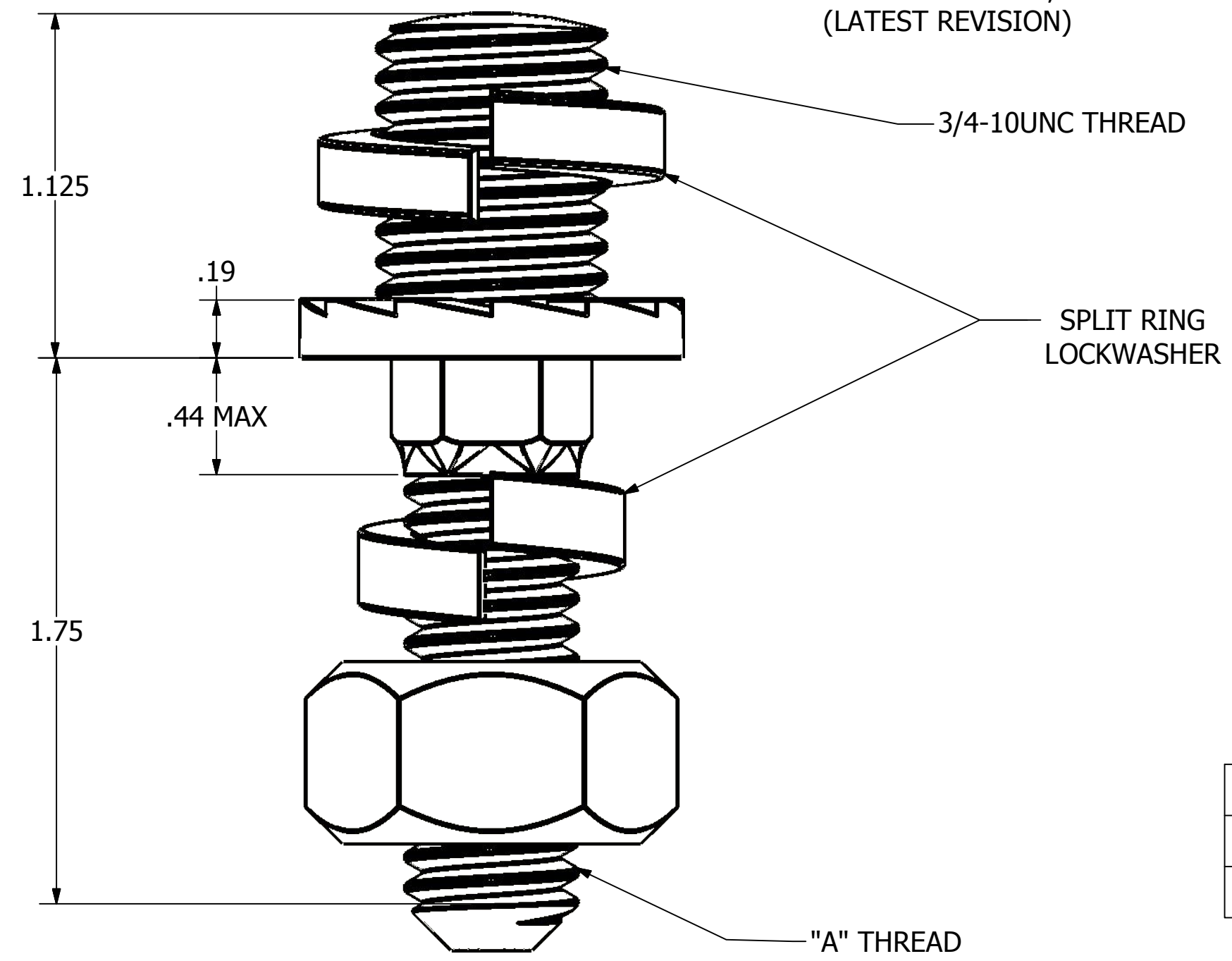

CATALOG NUMBER	"A"
DF19M1	5/8-13UNC-2B
DF19M3	3/4-10UNC-2B

CHANCE [®] <small>CONFIDENTIAL: THIS DRAWING AND ITS CONTENTS ARE CONFIDENTIAL AND THE EXCLUSIVE PROPERTY OF HUBBELL POWER SYSTEMS. NO PUBLICATION, DISTRIBUTION, OR COPIES MAY BE MADE WITHOUT THE WRITTEN CONSENT OF HUBBELL POWER SYSTEMS. HUBBELL POWER SYSTEMS UNPUBLISHED ALL RIGHTS RESERVED UNDER THE COPYRIGHT LAWS.</small>	 HUBBELL [®] <small>POWER SYSTEMS, INC.</small>	HUBBELL POWER SYSTEMS, INC.		
	LINE POST STUDS			
<small>DO NOT SCALE THIS DRAWING</small>	<small>DRN BY MRG</small>	<small>DWG NO.</small> SADF19M1	<small>REV</small> A	<small>SHEET 1 OF 1</small>