

==NOTES==

1. MAT'L: STEEL
2. FINISH: HOT DIP GALV. PER ASTM A153.
3. HARDWARE PACK SECURELY FASTENED TO FRAME FOR SHIPMENT.
4. FOR REPLACEMENT BOLTS ORDER CATALOG NUMBER DF34M1.

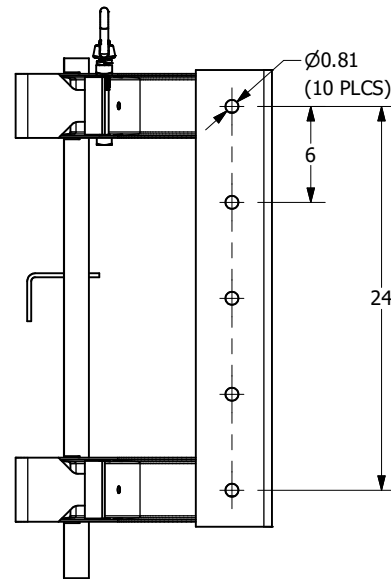
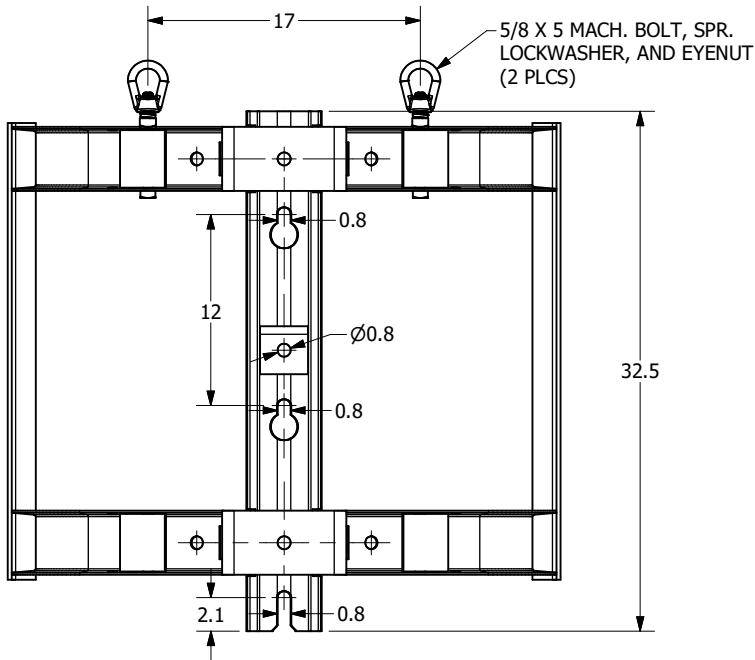
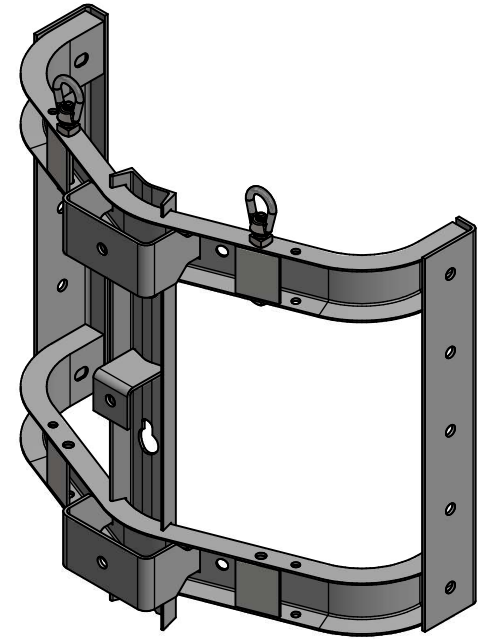
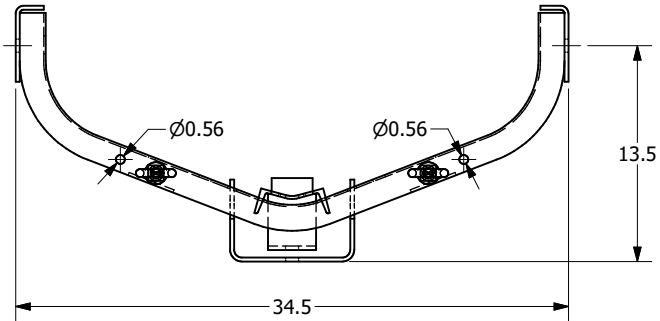

| HARDWARE PACK | |
|---------------|--------------------------------|
| AMOUNT | DESCRIPTION |
| 2 | 5/8 X 3-1/2 SQ. HD. MACH. BOLT |
| 4 | 5/8 X 2 SQ. HD. MACH. BOLT |
| 6 | 5/8 HEX HEAD NUT |
| 4 | 3/4 X 3-1/2 SQ. HD. MACH. BOLT |
| 2 | 3/4 X 2-1/4 SQ. HD. MACH. BOLT |
| 6 | 3/4 HEX HEAD NUT |

CHANCE[®]



HUBBELL POWER SYSTEMS, INC.

TITLE

CLUSTER
MOUNTING BRACKET

CONFIDENTIAL: THIS DRAWING AND ITS CONTENTS ARE CONFIDENTIAL AND THE EXCLUSIVE PROPERTY OF HUBBELL POWER SYSTEMS. NO PUBLICATION, DISTRIBUTION, OR COPIES MAY BE MADE WITHOUT THE WRITTEN CONSENT OF HUBBELL POWER SYSTEMS. HUBBELL POWER SYSTEMS UNPUBLISHED ALL RIGHTS RESERVED UNDER THE COPYRIGHT LAWS.

SIZE CAT / PART / ASSY NO.
C DT8C1L

DWG NO.
SADT8C1L

REV
A

DO NOT SCALE THIS DRAWING DRN BY CBW

DATE 9/14/22

SHEET 1 OF 1