

SQUARE NUT

STEM COLLAR

Ø6-1/2"

GALVANIZED STEEL BOLTS

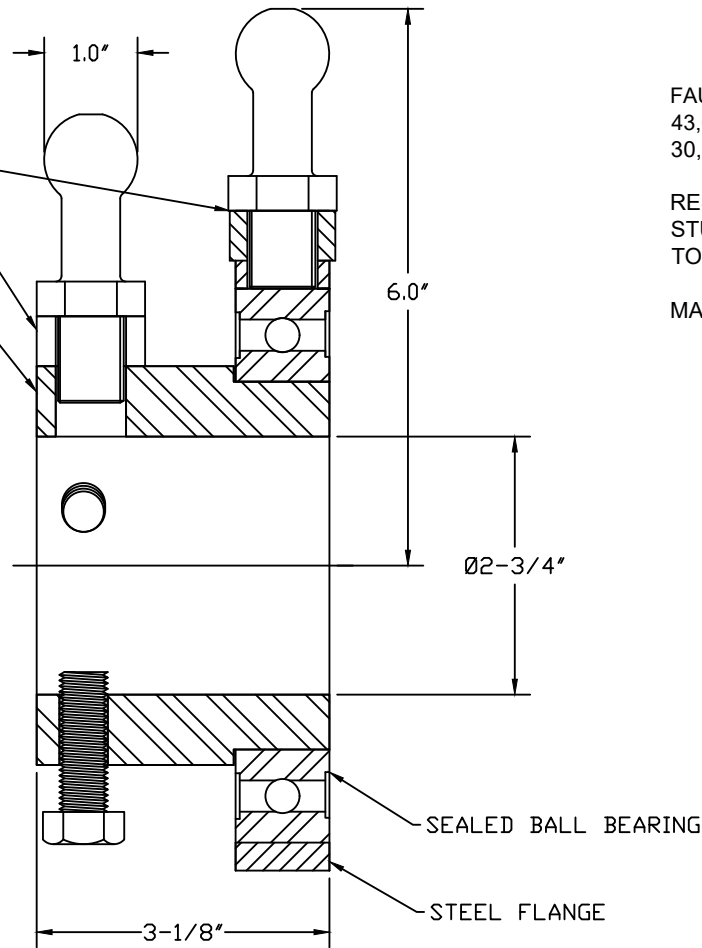

1.0"

6.0"

Ø2-3/4"

3-1/8"

SEALED BALL BEARING

STEEL FLANGE

-NOTES-

FAULT RATING FOR THIS ASSEMBLY:
43,000 AMPS FOR 15 CYCLES,
30,000 AMPS FOR 30 CYCLES.

RESISTANCE FROM BALL STUD TO BALL
STUD SHOULD BE LESS THAN OR EQUAL
TO 200 MILLIOHMS.

MAX PIPE DIAMETER: 2-11/16".

		HUBBELL® POWER SYSTEMS	
POWER SYSTEMS, INC.		TITLE	
SB SAGR43BS2		GR43BS2	
SIZE	DWG NO.	CAT / PART / ASSY NO.	REV
DO NOT SCALE THIS DRAWING	DRN BY HRW	DATE 1/11/2023	SHEET 01 OF 01