

CATALOG NUMBER (NOTES-2 & 3)	"A"	"B"
GS16005CP	5"	12.6"
GS16012CP	12"	19.6"
GS16018CP	18"	25.6"
GS16024CP	24"	31.6"
GS16030CP	30"	37.6"
GS16036CP	36"	43.6"
GS16042CP	42"	49.6"
GS16054CP	54"	61.6"
GS16060CP	60"	67.6"
GS16078CP	78"	85.6"
GS16096CP	96"	103.6"
GS16120CP	120"	127.6"
GS16144CP	144"	151.6"

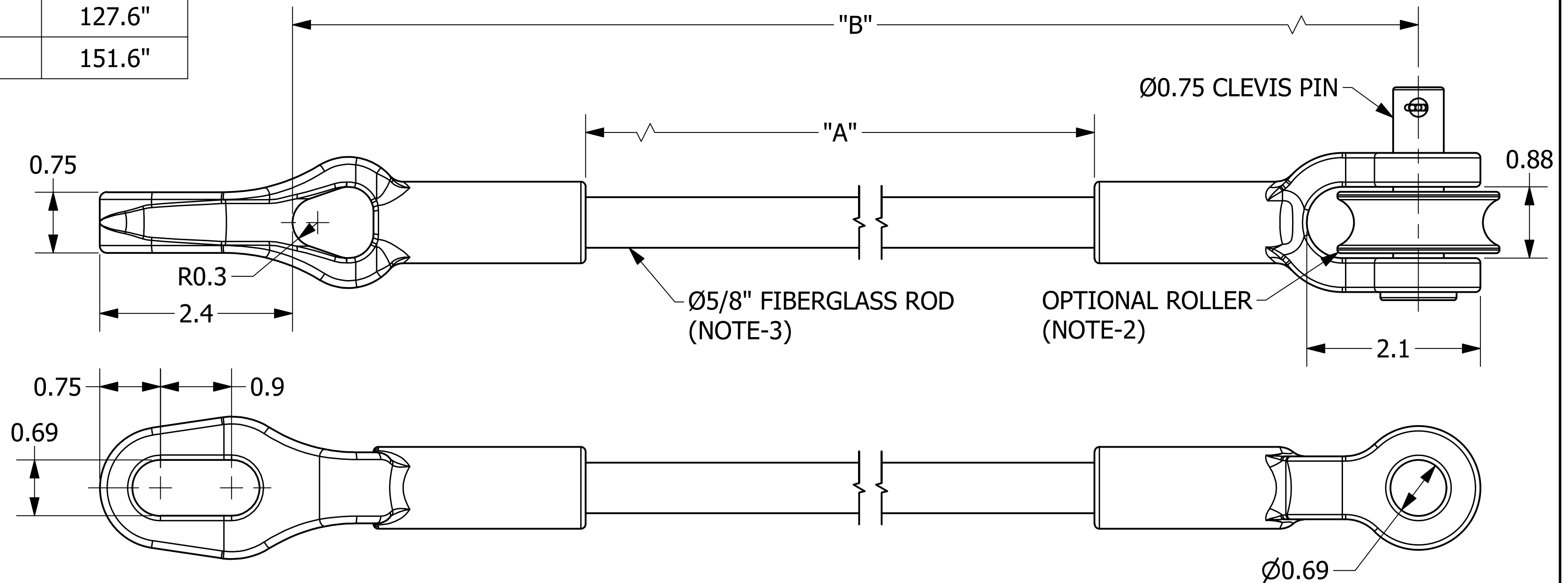
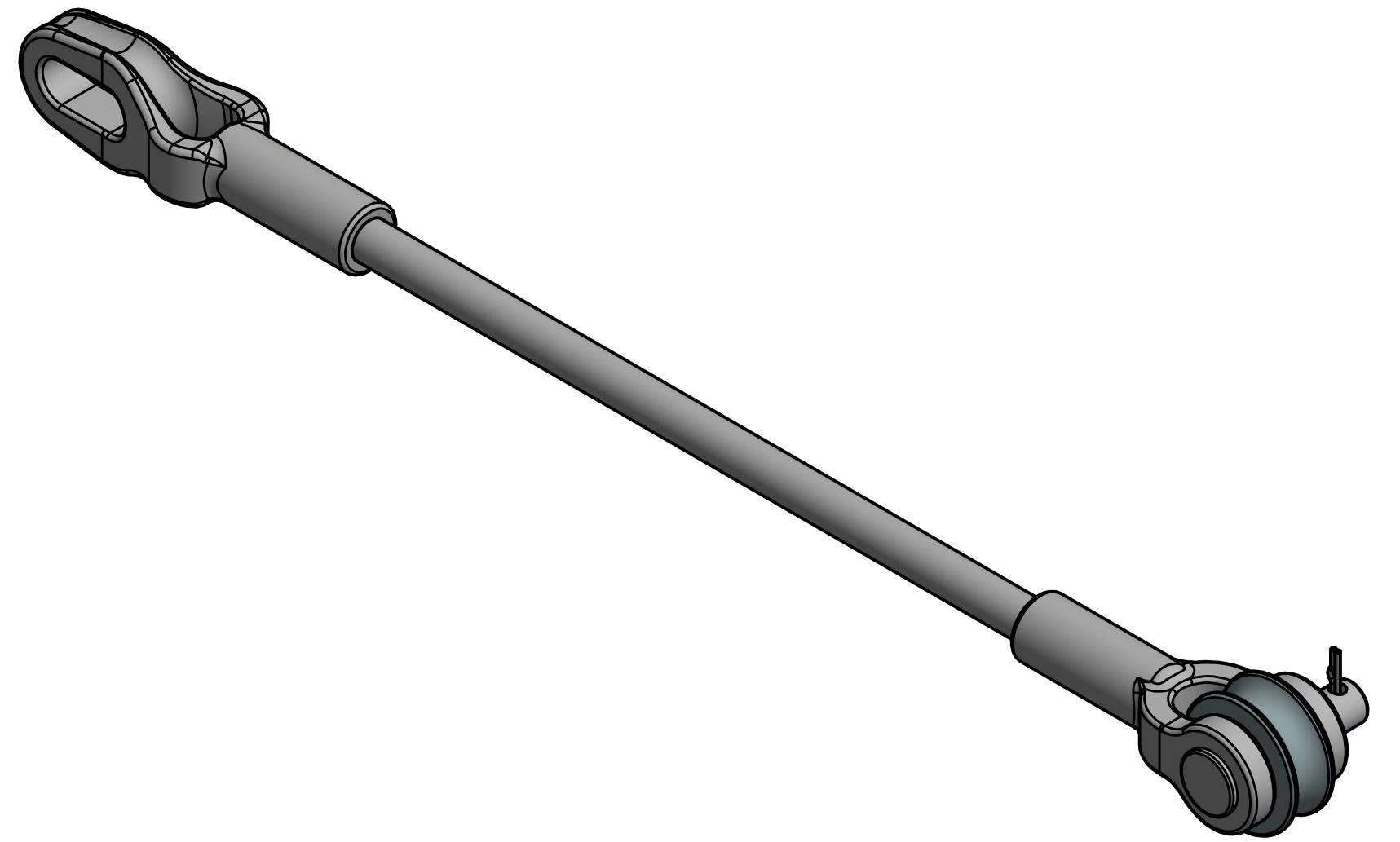

-NOTES-

1. END FITTING MATERIAL: GALVANIZED DUCTILE IRON
2. REPLACE "CP" SUFFIX WITH "CP1" TO DENOTE AN OPTIONAL ROLLER (EX. GS16012**CP1**)
3. ADD "SC" SUFFIX TO THE END OF THE CATALOG NUMBER TO DENOTE SILICONE COATED ROD (EX. GS16012CP1**SC**)
4. ULTIMATE BREAKING STRENGTH IS 16,000 LBS. RECOMMENDED MAXIMUM WORKING LOAD IS 50% OF THE ULTIMATE BREAKING STRENGTH.

CHANCE [®]	HUBBELL [®] HUBBELL POWER SYSTEMS, INC. POWER SYSTEMS, INC.		
	TITLE GUY STRAIN, 16K CLEVIS-THIMBLE/EYE		
SIZE C	CAT / PART / ASSY NO. SEE CHART	DWG NO. GS16XXXCP	REV A
DO NOT SCALE THIS DRAWING	DRN BY HOEK	DATE 11/30/22	SHEET 1 OF 1

CONFIDENTIAL: THIS DRAWING AND ITS CONTENTS ARE CONFIDENTIAL AND THE EXCLUSIVE PROPERTY OF HUBBELL POWER SYSTEMS. NO PUBLICATION, DISTRIBUTION, OR COPIES MAY BE MADE WITHOUT THE WRITTEN CONSENT OF HUBBELL POWER SYSTEMS. HUBBELL POWER SYSTEMS UNPUBLISHED ALL RIGHTS RESERVED UNDER THE COPYRIGHT LAWS.