

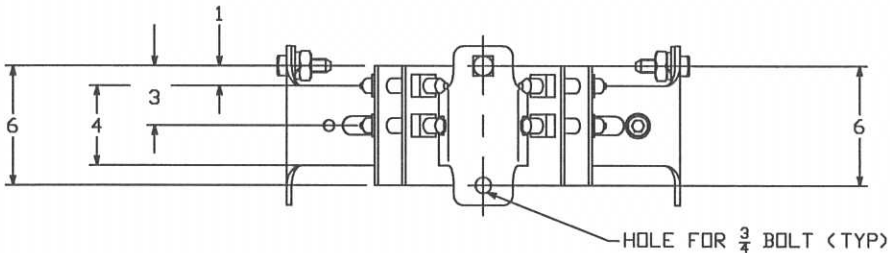

==NOTE==

1. MAT'L: STEEL, HOT DIP GALVANIZED PER ASTM A153 LATEST REVISION.
2. FITS POLE FROM 6 INCHES TO 10-1/2 INCHES IN DIAMETER.
3. ALL MAT'L IS UNASSEMBLED AND PACKAGED ONE PER CORRUGATED CARTON.

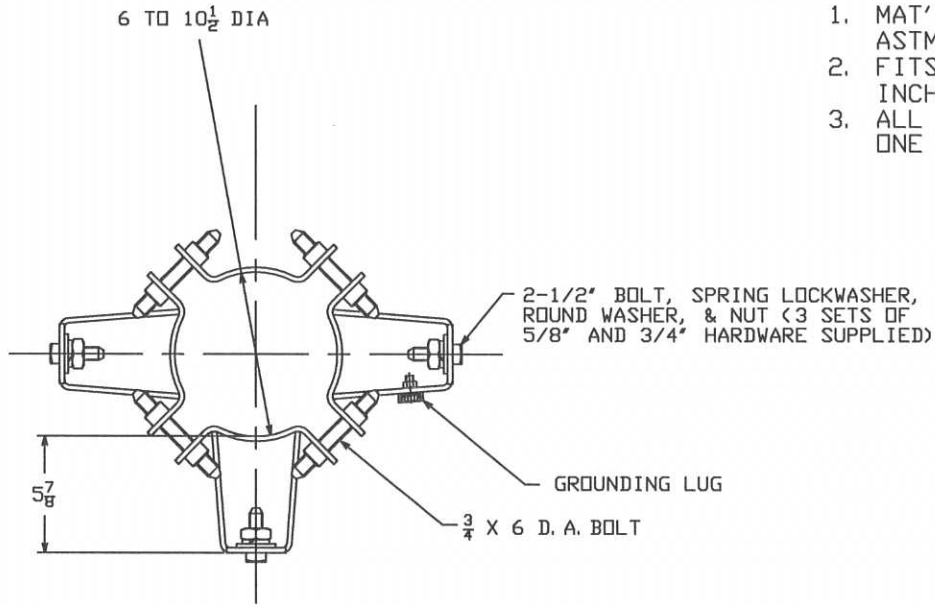

CAT. NO. HD5350BCH

CHANCE TOLERANCE CHART		 HUBBELL POWER SYSTEMS	
CONFIDENTIAL: THIS DRAWING AND ITS CONTENTS ARE CONFIDENTIAL AND THE EXCLUSIVE PROPERTY OF HUBBELL POWER SYSTEMS. NO PUBLICATION, DISTRIBUTION OR COPIES MAY BE MADE WITHOUT THE WRITTEN CONSENT OF HUBBELL POWER SYSTEMS. HUBBELL POWER SYSTEMS UNPUBLISHED ALL RIGHTS RESERVED UNDER THE COPYRIGHT LAWS.		TITLE TRANSFORMER MOUNTING BRACKET	
SIZE SBJ SAHD5350BCH	DWG NO. HD5350BCH	CAT / PART / ASSY NO. HD5350BCH	REV ---
DO NOT SCALE THIS DRAWING	DRN BY WILSON	DATE 08/03/11	SHEET 1 OF 1