

-NOTES-

1. MATERIAL: DUCTILE IRON GRADE 65-45-12 PER ASTM A536 (LATEST REVISION).
2. FINISH: HOT DIP GALVANIZE PER ASTM A153 (LATEST REVISION).
3. BRACKET CANTILEVER RATING: 20,000 IN*LBS.
4. PART IDENTIFIED WITH "CHANCE", "IB2", AND COUNTRY OF ORIGIN WHERE "XX" IS MANUFACTURER'S ID.

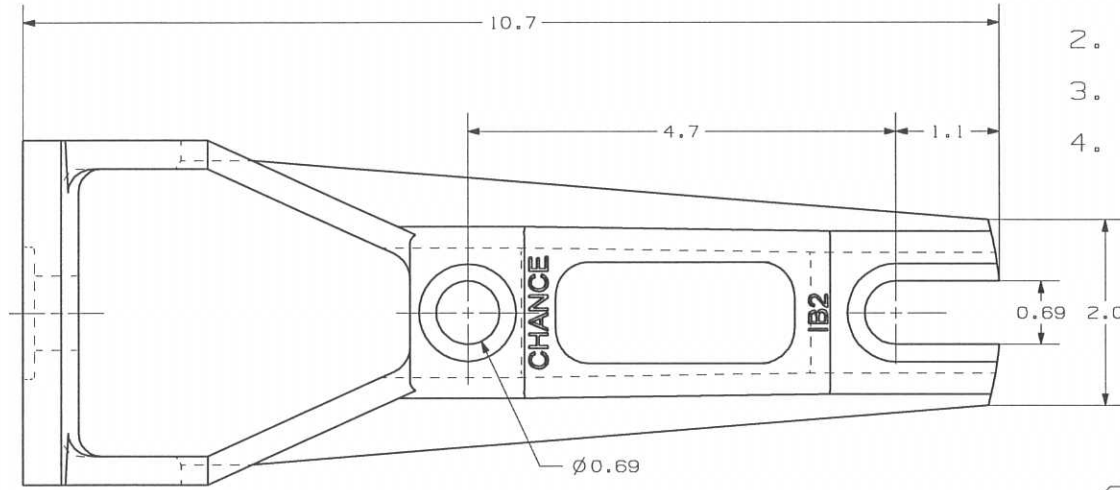

CATALOG NO. IB2

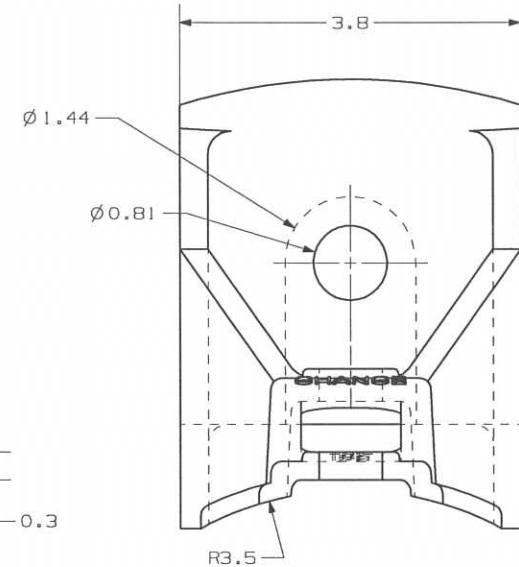
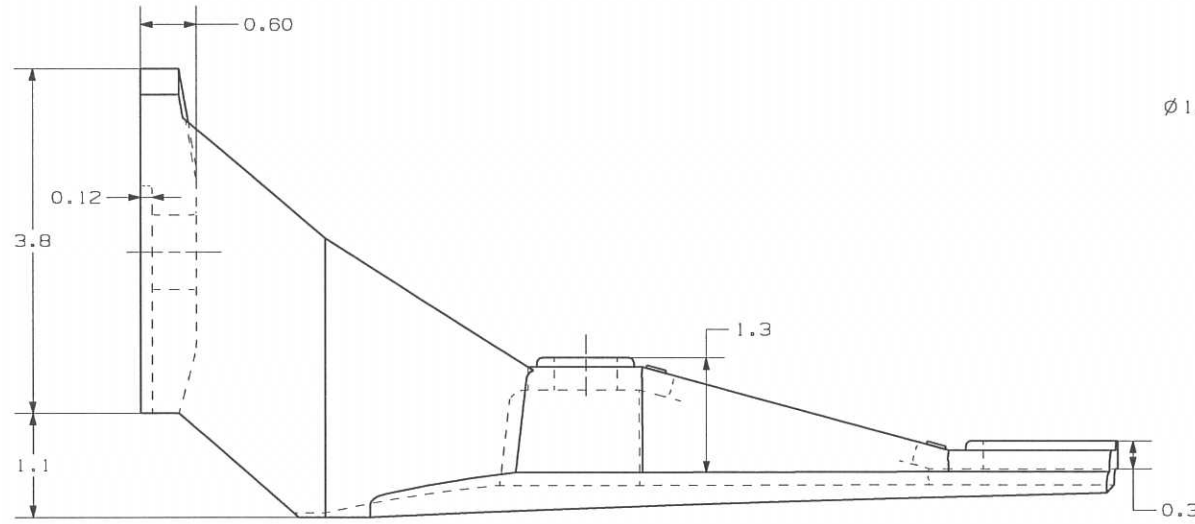

LATEST EC NO:		REV.	DATE	CHANGED BY	RESP ENGINEER
---		-	---	---	---
DO NOT SCALE THIS DWG THIRD ANGLE PROJECTION 1:50 DUAL DIMENSIONS IN-INCH, MM-MILLIMETER					
DRN BY:	DATE:	TITLE:		SIZE:	
WILSON	09/12/11	POLE TOP BRKT		C	
				DWG NO: SAIB2	

CONFIDENTIAL: THIS DRAWING AND ITS CONTENTS ARE CONFIDENTIAL AND THE EXCLUSIVE PROPERTY OF HUBBELL / A.B. CHANCE COMPANY. NO PUBLICATION, DISTRIBUTION OR COPIES MAY BE MADE WITHOUT WRITTEN CONSENT BY HUBBELL / A.B. CHANCE COMPANY. © 2001 HUBBELL/A.B. CHANCE. UNPUBLISHED - ALL RIGHTS RESERVED UNDER THE COPYRIGHT LAWS