

- NOTES -

1. MATERIAL: GRADE 60-40-18 DUCTILE IRON PER ASTM A536.
2. FINISH: HOT DIP GALVANIZED PER ASTM A153 (LATEST REV.).
3. CATALOG NUMBER PBA841P DOES NOT INCLUDE HARDWARE.

PART NUMBER	"A" BOLT	"B" SQUARE WASHER	"C" SQUARE NUT	"D" MF LOCKNUT
PSC2061101P	5/8" x 7" MACHINE BOLT	2-1/4" SQUARE WASHER	5/8" SQUARE NUT	5/8" MF LOCKNUT
PSC2060671P	5/8" x 8" CROSSARM BOLT	2" SQUARE WASHER	5/8" SQUARE NUT	5/8" MF LOCKNUT

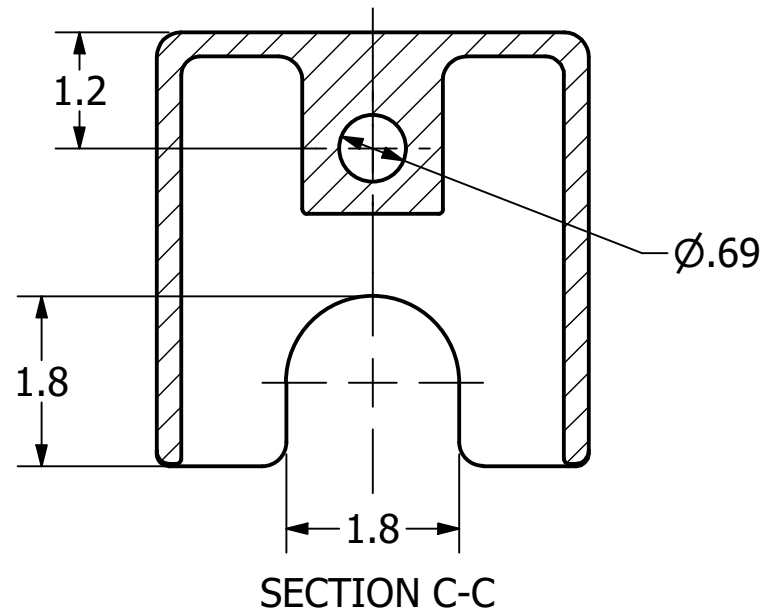

"A" MACHINE BOLT  
(NOTE 3)

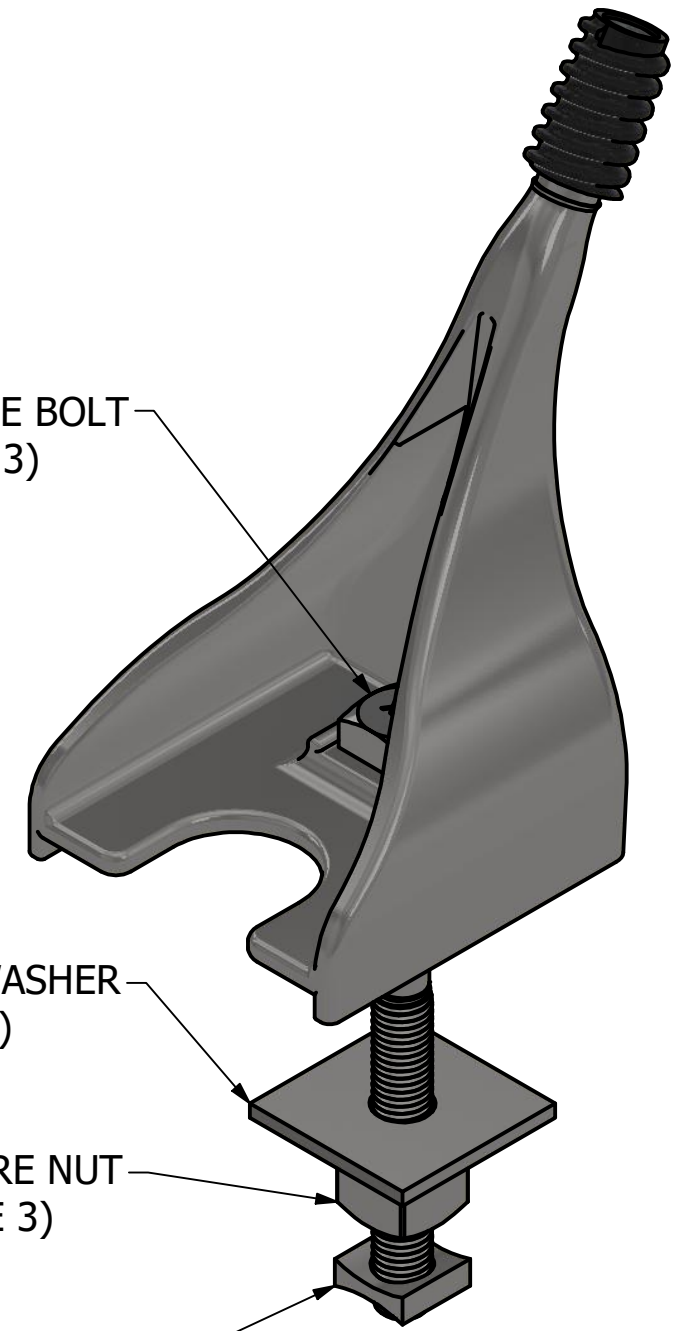

"B" SQUARE WASHER  
(NOTE 3)

"C" SQUARE NUT  
(NOTE 3)

"D" MF LOCKNUT  
(NOTE 3)

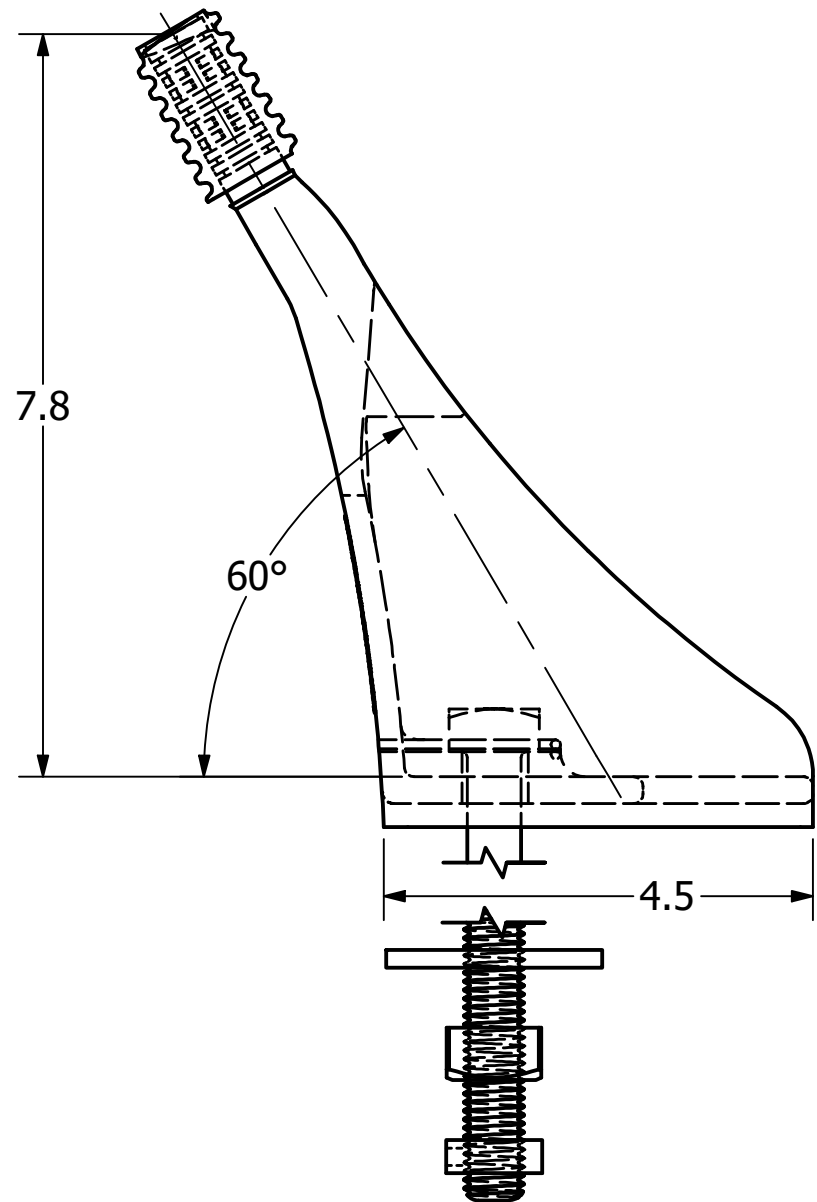

1" NYLON THREADS

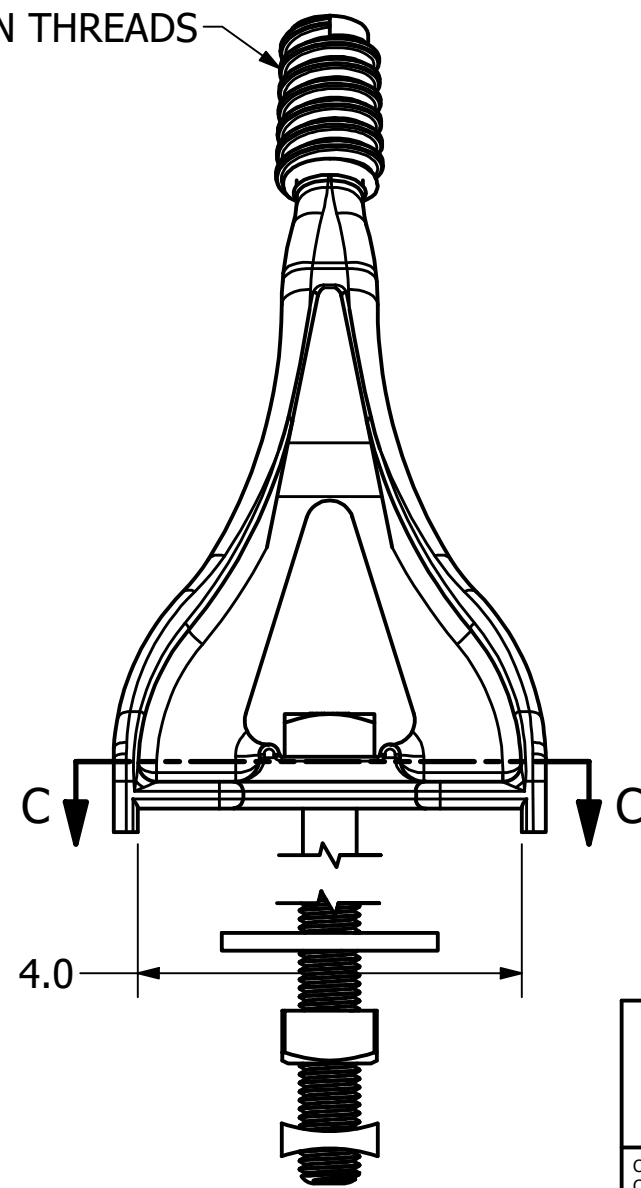

CATALOG NUMBERS: PBA841P, PSC2061101P AND PSC2060671P

<b>CHANCE</b> <sup>®</sup>	<b>HUBBELL</b> <sup>®</sup> HUBBELL POWER SYSTEMS, INC. POWER SYSTEMS, INC.		
	TITLE <b>NYLON CROSSARM ANGLE PIN</b>		
SIZE <b>B</b>	CAT / PART / ASSY NO. <b>SEE NOTE</b>	DWG NO. <b>SAPBA841P</b>	REV <b>A</b>
DO NOT SCALE THIS DRAWING	DRN BY HINKLE	DATE 12/28/2017	SHEET 1 OF 1

CONFIDENTIAL: THIS DRAWING AND ITS CONTENTS ARE CONFIDENTIAL AND THE EXCLUSIVE PROPERTY OF HUBBELL POWER SYSTEMS. NO PUBLICATION, DISTRIBUTION, OR COPIES MAY BE MADE WITHOUT THE WRITTEN CONSENT OF HUBBELL POWER SYSTEMS. HUBBELL POWER SYSTEMS UNPUBLISHED ALL RIGHTS RESERVED UNDER THE COPYRIGHT LAWS.