

=NOTES=

1. MATERIAL: 65-45-12 DUCTILE IRON PER ASTM A536 (LATEST REVISION).
2. HOT DIP GALVANIZE PER ASTM A153 (LATEST REVISION).
3. POLE RANGE - 10" DIA TO 16" DIA.

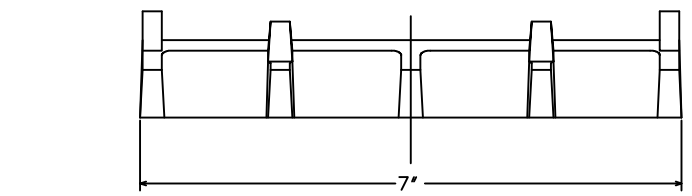

SECTION "A-A"

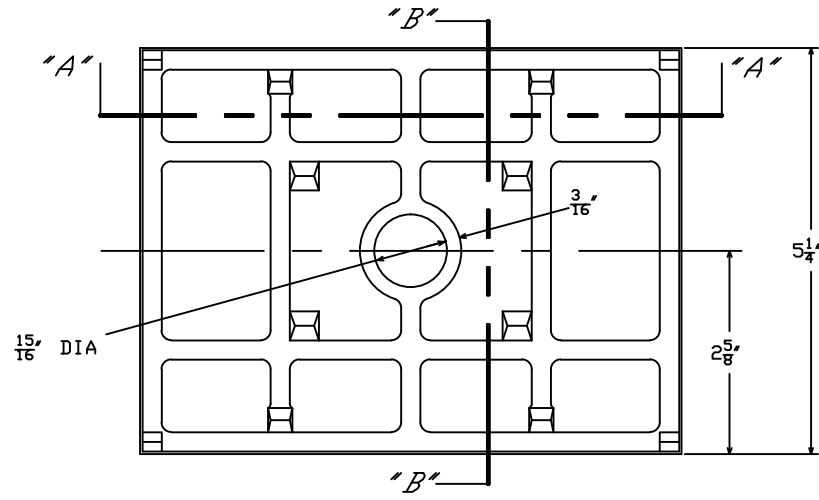
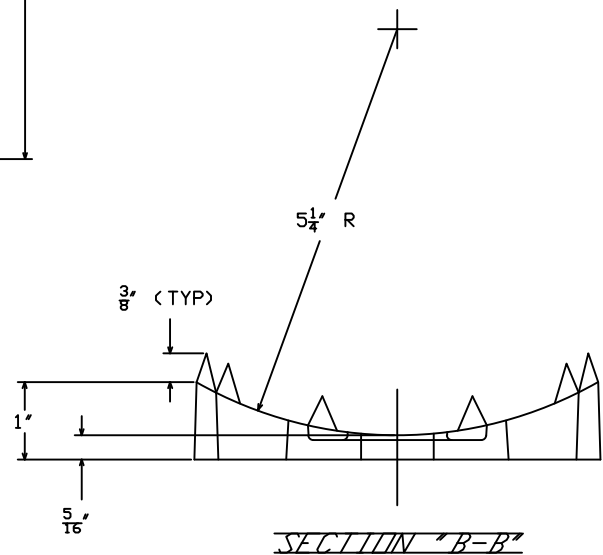

SECTION "B-B"

CATALOG NO.: PG5  
 WEIGHT: 3.7 LBS.

CHANCE TOLERANCE CHART		 <b>HUBBELL® POWER SYSTEMS</b> <small>POWER SYSTEMS, INC.</small>	
CONFIDENTIAL: THIS DRAWING AND ITS CONTENTS ARE CONFIDENTIAL AND THE EXCLUSIVE PROPERTY OF HUBBELL POWER SYSTEMS. NO PUBLICATION, DISTRIBUTION OR COPIES MAY BE MADE WITHOUT THE WRITTEN CONSENT OF HUBBELL POWER SYSTEMS. HUBBELL POWER SYSTEMS UNPUBLISHED. ALL RIGHTS RESERVED UNDER THE COPYRIGHT LAWS.		TITLE <b>POLE GAIN</b>	
SIZE SB	DWG NO. SAPG5	CAT / PART / ASSY NO. PG5	REV B
DO NOT SCALE THIS DRAWING	DRN BY WILSON	DATE 02/15/13	SHEET 1 OF 1