

- NOTES-
1. MATERIAL: HOT ROLLED STEEL
  2. FINISH HOT DIP GALVANIZE PER ASTM A153

3/8-16 X "B" BOLT, FLAT WASHER, LOCKWASHER, AND SQUARE NUT

1/2-13 X "C" CAPTIVE BOLT, EXT TOOTH WASHER, LOCKWASHER, AND HEX NUT

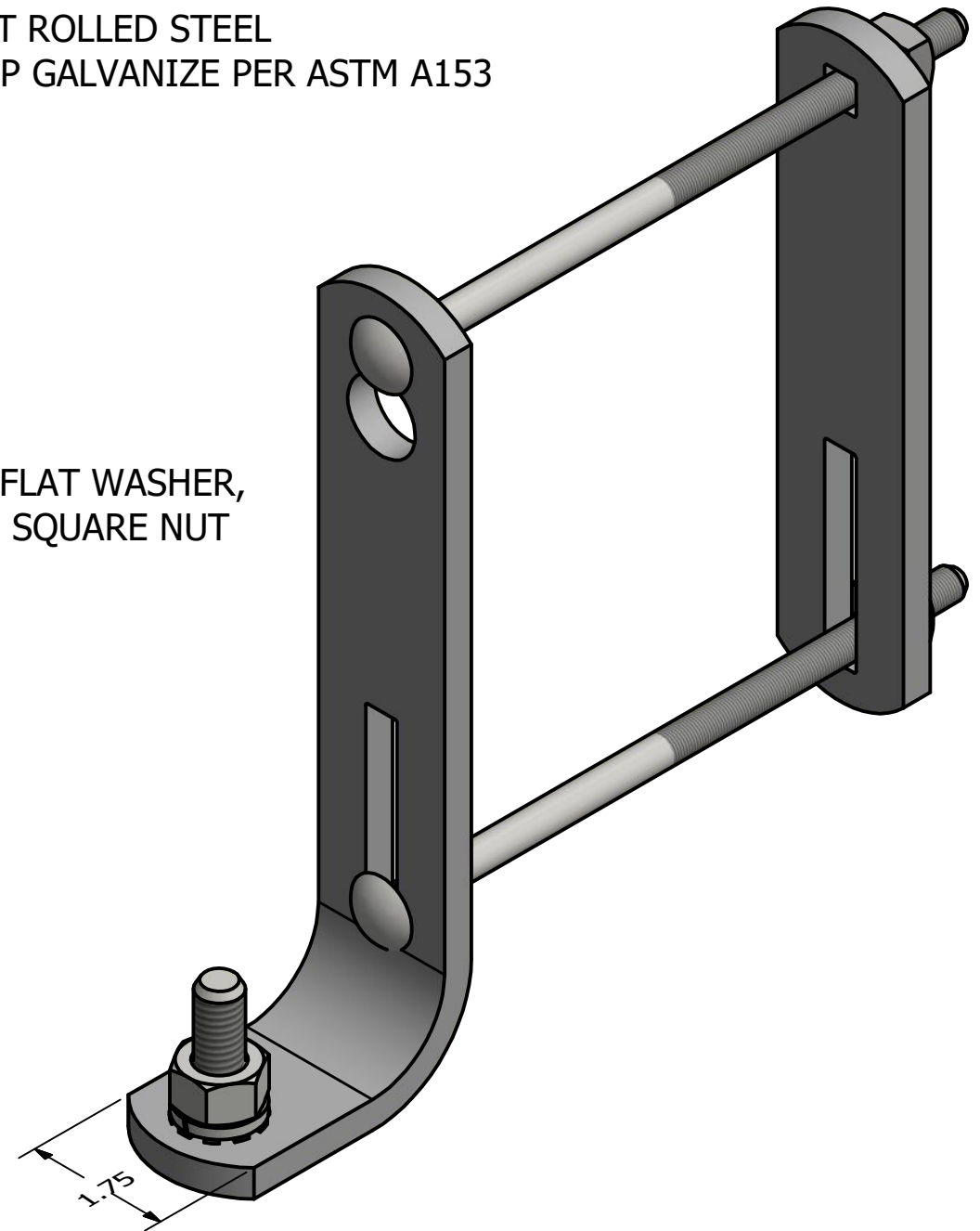

CATALOG NUMBER	A	B	C
PSC2060980	3 1/2" - 6"	8"	2"
PSC2061042	3 1/2" - 6"	8"	1 1/2"
PSC2061043	2 3/4" - 4"	6"	2"
PSC2061044	2 3/4" - 4"	6"	1 1/2"
PSC2061150	2 3/4" - 4.5"	6 1/2"	2"

<h1>CHANCE<sup>®</sup></h1>	<b>HUBBELL POWER SYSTEMS, INC.</b>			
	<b>EASY ON BRACKET</b>			
CONFIDENTIAL: THIS DRAWING AND ITS CONTENTS ARE CONFIDENTIAL AND THE EXCLUSIVE PROPERTY OF HUBBELL POWER SYSTEMS. NO PUBLICATION, DISTRIBUTION, OR COPIES MAY BE MADE WITHOUT THE WRITTEN CONSENT OF HUBBELL POWER SYSTEMS. HUBBELL POWER SYSTEMS UNPUBLISHED ALL RIGHTS RESERVED UNDER THE COPYRIGHT LAWS.	SIZE <b>B</b>	CAT / PART / ASSY NO. <b>SEE CHART</b>	DWG NO. <b>SAPSC2060980</b>	REV <b>A</b>
DO NOT SCALE THIS DRAWING	DRN BY HOEK	DATE 2/18/19	SHEET 1 OF 1	