

-NOTES-

1. ASSEMBLED COMPLETE AS SHOWN
2. MATERIAL: STEEL
3. FINISH: HOT DIP GALVANIZE PER ASTM A-153
4. ASSEMBLED WEIGHT: 105 LBS
5. ALL ASSEMBLY HARDWARE TO BE 5/8"
6. ACCEPTS 3/4" HARDWARE FOR POLE OR WALL MOUNT

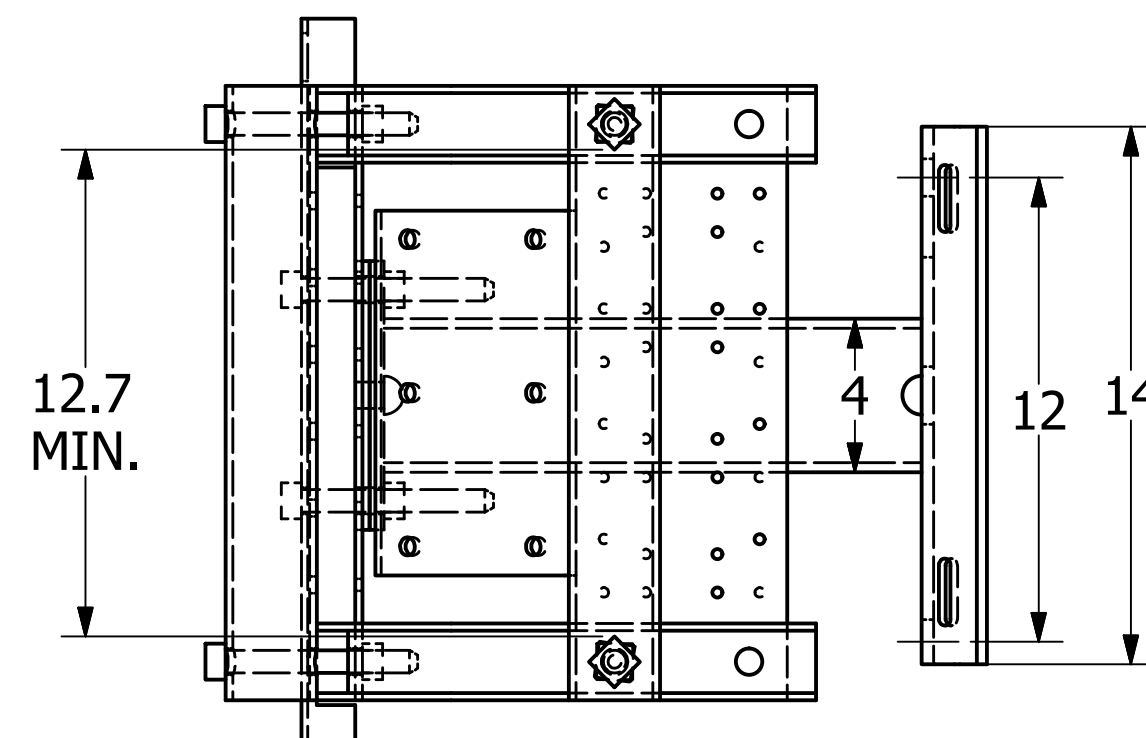
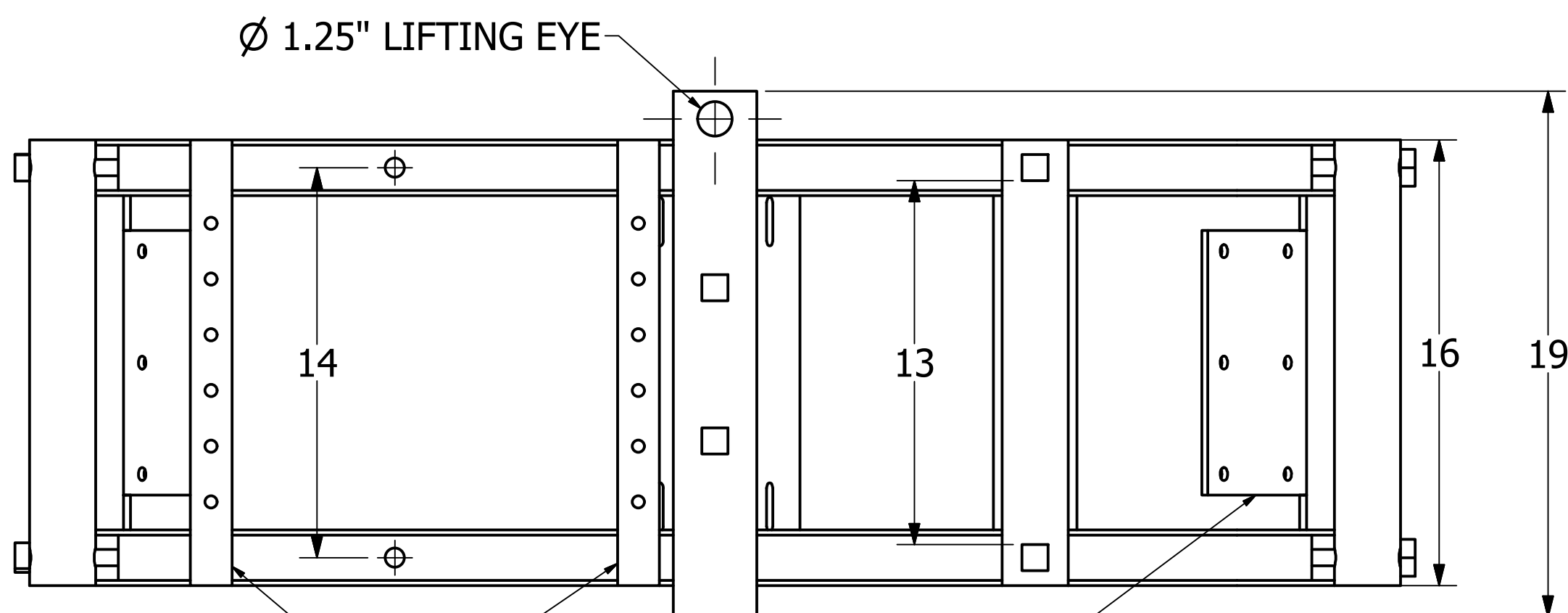
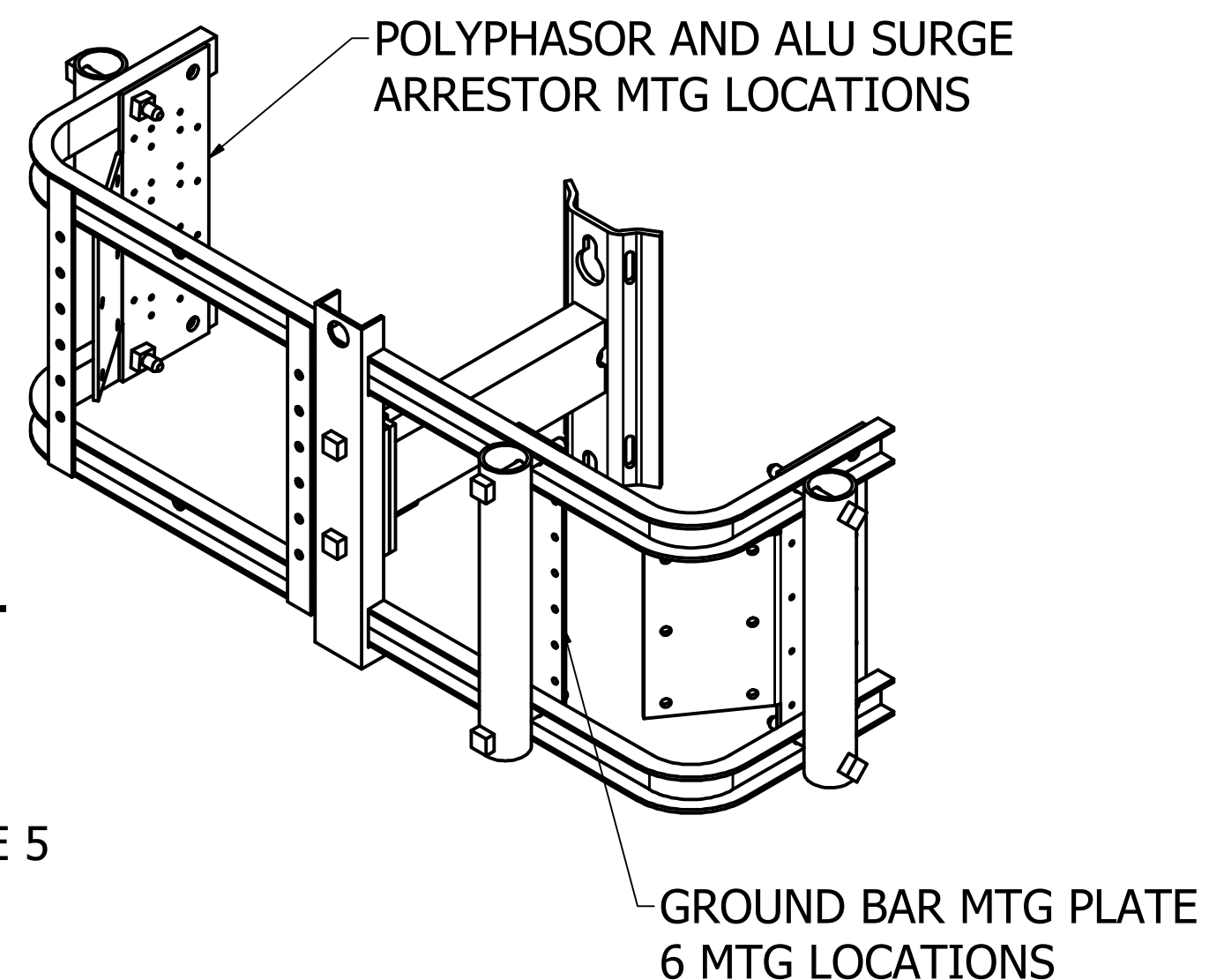
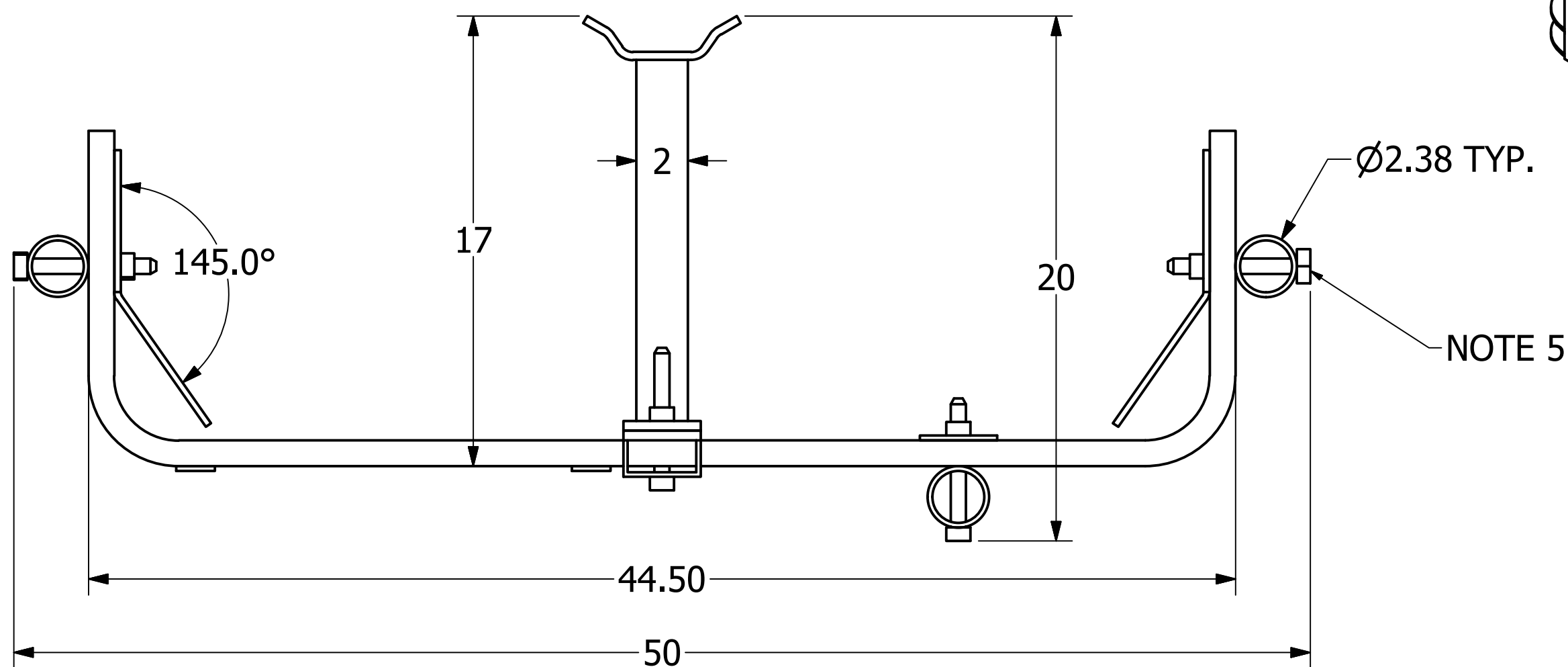

CIENA MTG BRACKETS

AMPHENOL ANTENNA MTG PLATE
UPPER AND LOWER POSITION

CHANCE®

HUBBELL® HUBBELL POWER SYSTEMS, Inc.
POWER SYSTEMS, INC.

CONFIDENTIAL: THIS DRAWING AND ITS CONTENTS ARE CONFIDENTIAL AND THE EXCLUSIVE PROPERTY OF HUBBELL POWER SYSTEMS. NO PUBLICATION, DISTRIBUTION OR COPIES MAY BE MADE WITHOUT THE WRITTEN CONSENT OF HUBBELL POWER SYSTEMS. HUBBELL POWER SYSTEMS UNPUBLISHED ALL RIGHTS RESERVED UNDER THE COPYRIGHT LAWS.

TITLE -			
SMALL CELL UNIVERSAL BRACKET			
SIZE	CAT / PART / ASSY NO.	DWG NO.	REV
SC	PSC208-0261	SAPSC208-0261	-
DO NOT SCALE THIS DRAWING	DRN BY ADAMS	DATE 03/10/14	SHEET - OF -