

I.P.S. PIPE ACCOMMODATED		WIRE RANGE		
NOMINAL SIZE	ACTUAL OUTER DIAMETER		AWG	METRIC WIRE SIZE
	(IN)	(mm)		
1 1/4	1.660	[42]	6 STR (.184) - 250kcmil (.575)	16mm ² STR [5.1] 120mm ² STR [14.4]
1 1/2	1.900	[48]		
2	2.375	[60]		

REV	DATE	DESCRIPTION	ECO	BY	CHK.
B	06/09/2020	REDRAWN IN INVENTOR AND CONDUCTOR HOLE CHAMFER REMOVED	53668	PB	RG

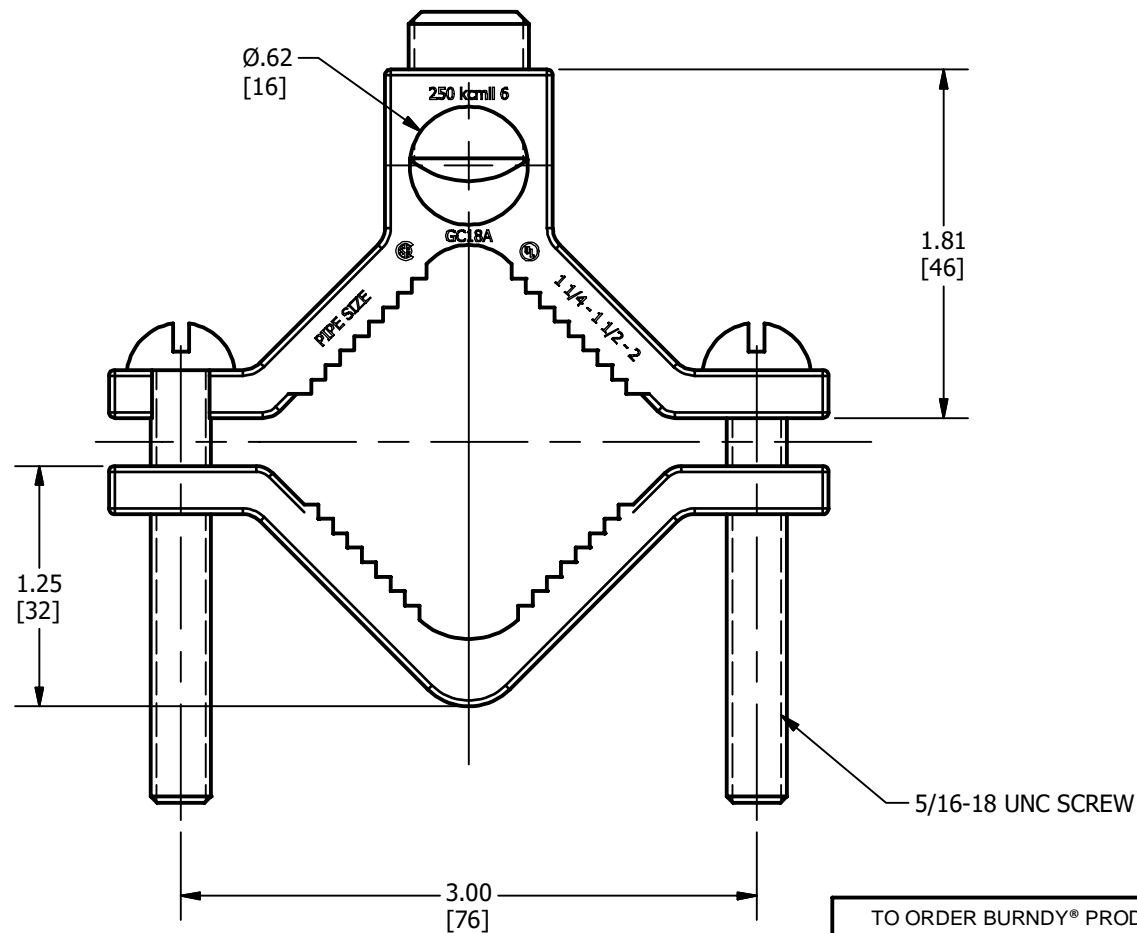
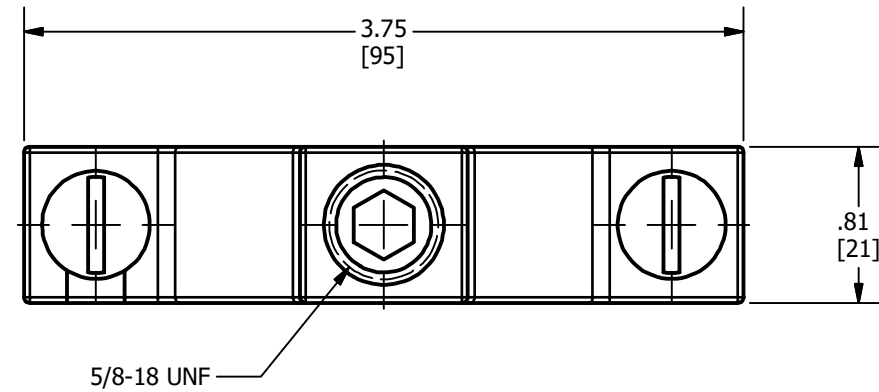

NOTES:

1. MATERIAL: ALUMINUM (5/16 - 18 UNC SCREWS ARE STEEL).
2. DIMENSIONS IN BRACKETS [] ARE IN MILLIMETERS ROUNDED OFF TO THE NEAREST MILLIMETER, UNLESS OTHERWISE SPECIFIED AND ARE FOR REFERENCE ONLY.
3. UL467 LISTED, FILE NO. E9999.
4. PENETROX™ OXIDE INHIBITING JOINT COMPOUNDS ARE RECOMMENDED. FOR ALL ALUMINUM APPLICATIONS.
5. RECOMMENDED TORQUE: 180 LBin [20.3Nm].

TO ORDER BURNDY® PRODUCTS CALL
 UNITED STATES
 1-800-346-4175 (LONDONDERRY, NH)
 CANADA:
 1-800-361-6975 (QUEBEC)
 1-800-387-6487 (ALL OTHER PROVINCES)
 FOR PRODUCT INFO: <http://www.burndy.com>

GROUND CLAMP	
ITEM NO: 262003	
CAT. NO: GC18A	
DRAWN BY: D. BOISVERT 04/12/1999	
CHECKER: J. MICHAUD 04/19/1999	
DSN APRVL: G. DITROIA 05/25/1999	
MFG APRVL: --	
QA APRVL: J. BRODEUR 05/26/1999	
MKT APRVL: P. MITCHELL 05/24/1999	
PROD FAM: --	
PROJECT #: --	SIZE
DOCUMENT TYPE: SALES	B
REL LEVEL: Released	
DRAWING NO	REV
SC212058-01	B
SHEET 1 OF 1	

