

CATALOG NUMBER	CONDUCTOR SEE LAST COLUMN		O.D.	B APPROXIMATE	L APPROXIMATE	TOOLS, DIE SET CATLOG NUMBER & (CRIMPS PER END)						INSTALLATION TOOL INDEX NUMBER	ALSO ACCOMMODATES			
	ACSR	STR				MD7, MD6	Y35, Y750	Y45	Y46	Y48B	Y60BHU		ALUMINUM	STR.		
YCS4R	#4 (.250)	6-1	0.397	2.38	4.91	W237(4)	U237(2)	U237(2)	U237(2)	--	--	237	4(.232)	5	7	
	#4 (.257)	7-1														
YCS2R	#2 (.316)	6-1	0.500	2.38	4.91	W239(4)	U239(2)	U239(2)	U239(2)	--	--	239	2(.292)	5	7	
	#2 (.325)	7-1														
YCS1R	#1 (.355)	6-1	0.563	3.12	6.37	W241(8)	U241(4)	U241(4)	U241(4)	--	--	241	--	--	--	
YCS25R	1/0 (.398)	6-1	0.621	3.48	7.09	W-BG(5)	U-BG(6)	U-BG(6)	U-BG(6)	--	--	243	1/0 (.368)	7	19	
						W243(7)	U243(4)	U243(4)	U243(4)	--	--					1/0 (.373)
YCS26R	2/0 (.447)	6-1	0.696	3.55	7.05	W245(8)	U245(4)	U245(4)	U245(4)	--	--	245	2/0 (.414)	7	19	
YCS27R	3/0 (.502)	6-1	0.781	2.81	5.75	W247(6)	U247(3)	U247(3)	U247(3)	--	--	247	3/0 (.464)	7	19	
	110.8 kcmil	12-7														3/0 (.470)
YCS28R	4/0 (.563)	6-1	0.875	2.81	5.75	W249(6)	U249(3)	U249(3)	U249(3)	--	--	249	4/0 (.522)	7	19	
		6-7														L249(2)
YCS30R	266.8 kcmil (.608)	18-1	1.000	3.18	6.47	W251(12)	U251(6)	U251(6)	U251(6)	--	--	251	266.8 kcmil (.586)	7	19	
	266.8 kcmil (.633)	6-7											266.8 kcmil (.593)			
	266.8 kcmil (.642)	26-7														
YCS31R	300 kcmil (.680)	26-7	1.062	3.96	8.00	--	--	--	--	--	--	315	--	--	--	
YCS321R	336.4 kcmil (.684)	18-1	1.125	3.18	6.47	--	U490(5)	U490(5)	U490(5)	--	--	L490(2)	490 OR 547	3	336.4 kcmil (.666)	19
YCS33R	336.4 kcmil (.721)	26-7	1.141	4.31	8.74	--	U316(6)	U316(6)	U316(6)	--	--	L316(2)	316	397.5 kcmil (.724)	19	
	336.4 kcmil (.741)	30-7														
	397.5 kcmil (.783)	26-7														
YCS35R	397.5 kcmil (.806)	30-7	1.250	4.31	8.80	--	U317(6)	U317(6)	U317(6)	--	--	L317(2)	317	477 kcmil (.783)	19	
	397.5 kcmil (.743)	18-1												477 kcmil (.795)	37	
														500 kcmil (.813)	37	
														500 kcmil (.815)	61	
YCS361R	477 kcmil (.814)	18-1	1.300	4.06	8.25	--	U327(6)	U327(6)	U327(6)	--	--	L327(2)	327	500 kcmil (.813)	37	
YCS37R	477 kcmil (.858)	26-7	--	4.31	8.75	--	U261(6)	U261(6)	U261(6)	--	--	L261(2)	261	--	--	
	477 kcmil (.883)	30-7														
	477 kcmil (.846)	24-7														
YCS33RGI	336.4 kcmil (.721)	26-7	1.062	2.56	5.25	--	--	--	--	--	--	193	--	--	--	
	336.4 kcmil (.741)	30-7														
YCS011R	80 kcmil (.367)	8-1	0.696	3.55	7.18	--	U245(4)	U245(4)	U245(4)	--	--	L245(2)	245	--	--	
YCS261R	134.6 kcmil (.530)	12-7	1.141	4.33	8.77	--	U316(7)	U316(7)	U316(7)	--	--	L316(2)	316	--	--	
		5														
YCS271R	159 kcmil (.576)	12-7	1.250	4.31	8.80	--	U317(7)	U317(7)	U317(7)	C317(2)	L317(2)	317	--	--	--	
YCS284R	211.3 kcmil (.663)	12-7	1.250	4.33	8.81	--	U317(7)	U317(7)	U317(7)	C317(2)	L317(2)	317	--	--	--	
YCS251R	101.8 kcmil (.461)	12-7	1.141	4.30	8.76	--	U316(7)	U316(7)	U316(7)	--	--	L316(2)	316	--	--	
YCS321RGI	336.4 kcmil (.684)	18-1	1.141	4.03	8.18	--	--	--	--	--	--	--	--	--	--	
YCS38R	500 kcmil (.904)	30-7	1.500	3.75	7.62	--	--	--	--	--	--	614	--	--	--	

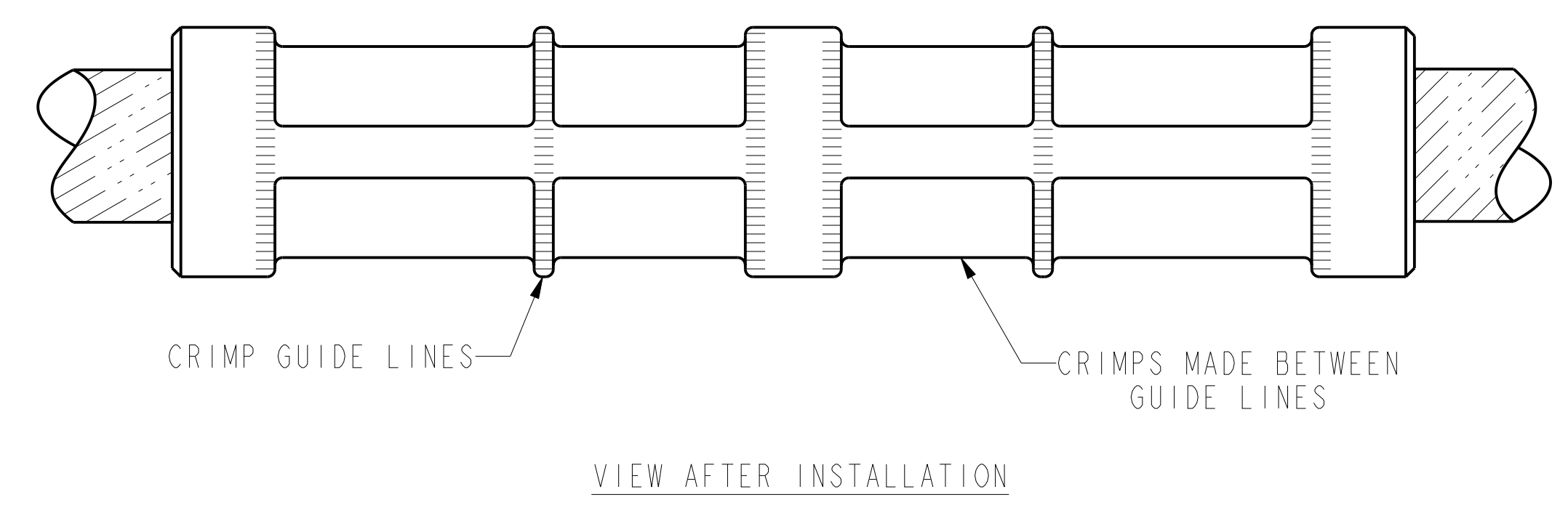
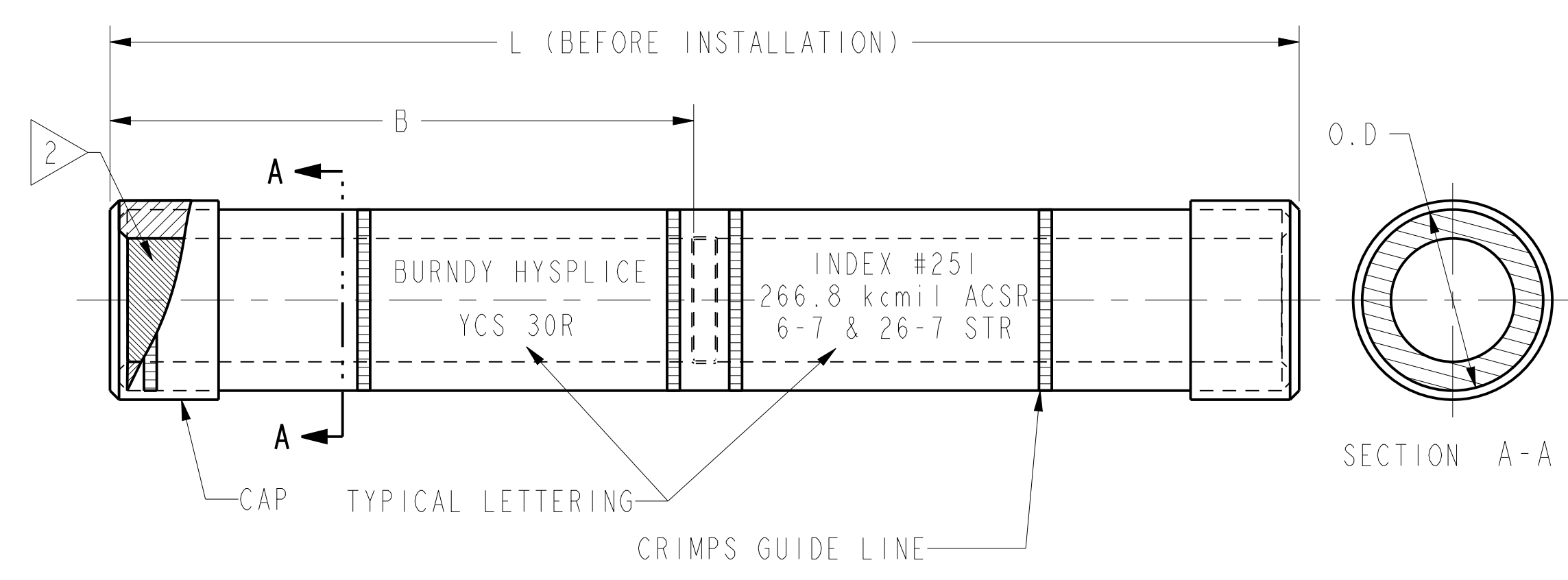

- NOTES:
- MATERIAL: ALUMINUM.
  - BARRELS FILLED HALF FULL WITH PENETROX™ AND CAPPED.
  - INCLUDED KEARNEY DIE 1-1/8 UNDER INDEX COLUMN TO CATALOG NUMBER YCS321R.
  - YCS27R CAN BE USED AS A REDUCER LOOP SPLICE FPR 3/0 A.C.S.R. TO 2/0 A.C.S.R.
  - THESE LOOP HYSPLICES™ ARE DESIGNED FOR INSTALLATION WITH THE SAME DIE SETS USED FOR INSTALLING FULL TENSION HYSPLICES™. NOTE THAT Y458 HYPRES™ MUST BE USED.
  - "U" DIES USED WITH ADAPTER PT6515.
  - FLAT SIDED.
  - FOR ADDITIONAL INSTALLATION DATA SEE SA039023.
  - MD6 USE BG GROOVE, 12 CRIMPS PER END.
  - ALSO ACCOMMODATES 556.5(.879) ACSR 18-1
  - "U" DIES USED WITH ADAPTER PUADP-1

TO ORDER BURNDY® PRODUCTS CALL

UNITED STATES  
1-800-346-4175 (LONDONDERRY, NH)

CANADA:  
1-800-361-6975 (QUEBEC)  
1-800-387-6487 (ALL OTHER PROVINCES)

FOR PRODUCT INFO: <http://www.burndy.com>

HYSPLICE™, LOOP (ACSR)

ITEM NO: --

CAT. NO: YCS-P (TABLE)

DRAWN BY: E.T.S 08/29/1949

CHECKER: C.S 02/23/1950

DSN APPVL: B.KEENAN 02/01/2014

MFG APPVL: W.ZAHLMAN 01/25/2014

QA APPVL: C.ACKERMAN 01/27/2014

MKT APPVL: J.HALL 02/11/2014

PROD FAM: --

PROJECT #: --

DOCUMENT TYPE: Sales

REL LEVEL: Released

SCALE: 2:1

DRAWING NO: SD021209-01

REV: C

SHEET 1 OF 1

**BURNDY**