

CATALOG NUMBER	STRANDED COPPER CONDUCTOR ACCOMMODATED			BOLT SIZE	METRIC BOLT SIZE	DIMENSIONS								
	CODE (AWG)	NAVY	METRIC SIZE (CLASS 2)			B	C	E	K DIA.	L	N	O.D.	T REF.	Z MIN.
YA472N	1750 kcmil	-----	-----	1/2	M12	3.44 [87]	2.90 [74]	1.75 [44]	.56 [14]	7.89 [200]	.63 [16]	1.98 [50]	.42 [11]	.64 [16]
YA482N	2000 kcmil (1.632 DIA.)	-----	1000mm ² STR [42.2]	1/2	M12		3.10 [79]			7.98 [203]		2.13 [54]	.46 [12]	

REV	DATE	DESCRIPTION	ECO	BY	C.H.K.
C	2018-03-23 00:00:00 EDT	DRAWING UPDATED AS PER MARKUP	48772	YR	VS

INSTALLATION TOOLING (# CRIMPS)																
CATALOG NO.	COLOR CODE	DIE INFORMATION		MECHANICAL RATCHET					HYDRAULIC					DIELESS (# CRIMPS)	WIRE STRIP LENGTH	
		DIE INDEX	TYPE	Y1MRTC	OUR840	MD6 MD7	MD6--R2 BAT500	MD7-34R	Y34A Y34B Y34BH	Y35, Y39 Y750, BAT35 BAT750	Y46	Y45	Y48B			Y60BHU
YA472N	GRAY	33	GRAY DIE SET	-----	-----	-----	-----	-----	-----	-----	-----	-----	-----	C47R(6)	L47RT(3)	3-1/2"
			NEST INDENTOR	-----	-----	-----	-----	-----	-----	-----	-----	-----	-----	-----	C47D(3) Y48PR	
YA482N	BROWN	34	BROWN DIE SET	-----	-----	-----	-----	-----	-----	-----	-----	-----	-----	-----	L48RT(4)	3-1/2"
			NEST INDENTOR	-----	-----	-----	-----	-----	-----	-----	-----	-----	-----	-----	C48D(3) Y48PR	

CONNECTOR SIZE	TOLERANCES						
	B	C	E	K DIA.	L	N	O.D.
-6C THRU -25	±.06	±.04	±.02	±.02	±.09	±.03	±.01
-26 THRU -34	±.08	±.04	±.02	±.02	±.12	±.03	±.01
-35 AND UP	±.09	±.06	±.02	±.02	±.15	±.06	±.01

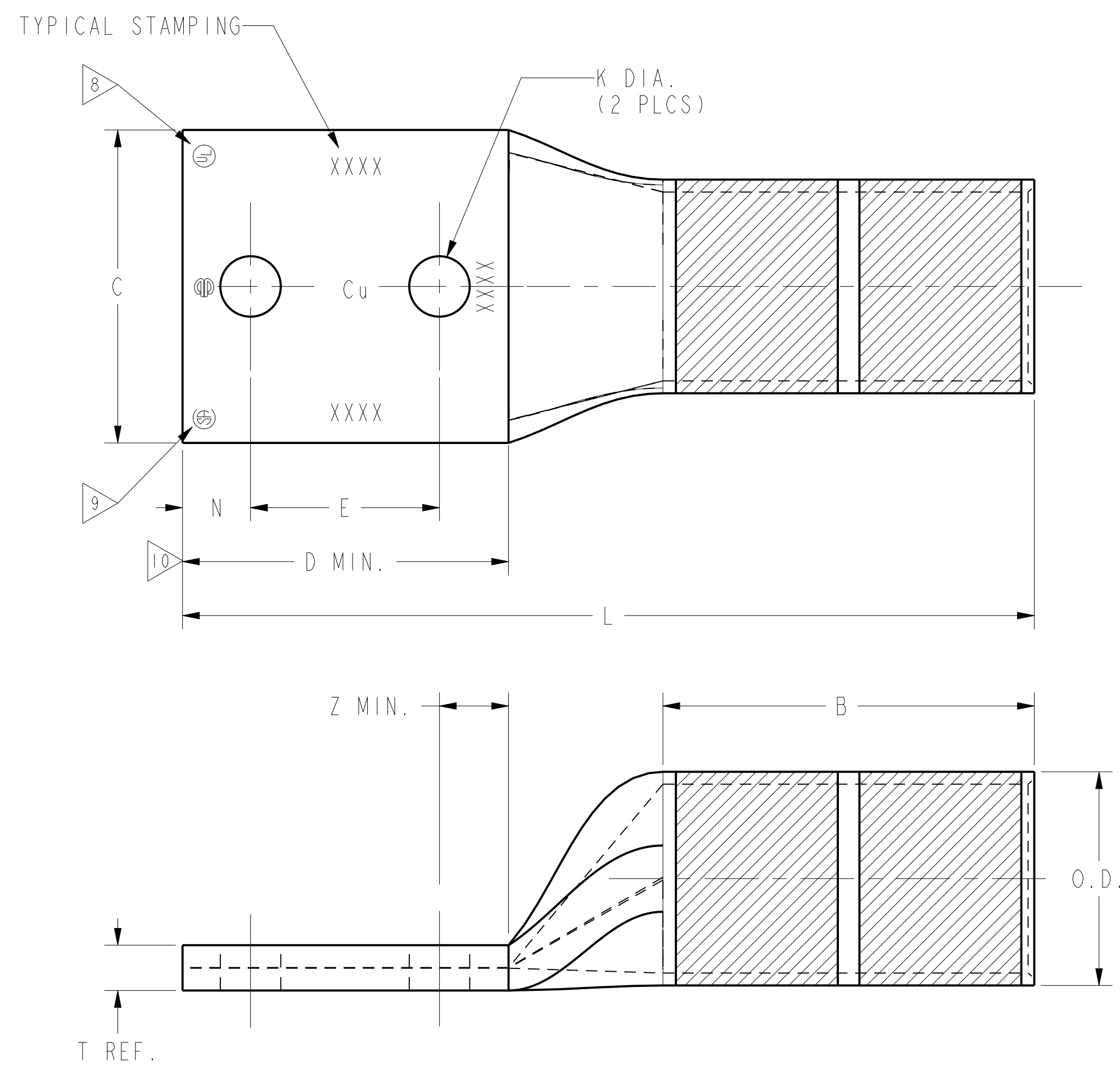

- NOTES:
- MATERIAL: COPPER TUBING.
 - FINISH: TIN PLATED. FOR UNPLATED VERSION, ADD SUFFIX "BR" TO CATALOG NUMBER EX. YA472NBR.
 - CATALOG # PT6515 ADAPTOR IS REQUIRED TO USE "U" DIES IN Y45 SERIES TOOLS.
 - CATALOG # PUADP-1 ADAPTOR IS REQUIRED TO USE "U" DIES IN Y46 SERIES TOOLS.
 - PERMANENT DIE IN TOOLING.
 - DIMENSIONS IN BRACKETS [] ARE IN MILLIMETERS ROUNDED OFF TO THE NEAREST MILLIMETER, UNLESS OTHERWISE NOTED, AND ARE FOR REFERENCE ONLY.
 - FOR USE BY CUSTOMERS THAT HAVE THIS HYPRESSM NO NEW Y34A HYPRESSESM ARE BEING PROCESSED. Y34A USES A--D TYPE NEST DIES.
 - CONNECTORS ARE UL LISTED; UNDRILLED VERSIONS ARE NOT UL LISTED.
 - CONNECTORS ARE CSA CERTIFIED; UNDRILLED VERSIONS ARE NOT CSA CERTIFIED.
 - FOR UNDRILLED VERSIONS ADD SUFFIX "-U" TO END OF CATALOG NUMBER. FOR UNDRILLED VERSIONS, USE D MIN. = N MAX. + E MIN. + Z MIN.
 - "X", "W-RT", "W-VT", "U", & "L" DIE SETS ARE COLOR CODED. "A", "B", AND "C" DIES ARE NOT COLOR CODED. NESTS AND INDENTOR TYPE ARE NOT COLOR CODED.
 - ADD SUFFIX "DT" OR "DTS" TO ORDER LUGS WITH CRIMP BARREL SEALED AIR TIGHT INSIDE THE TRANSITION.

REFERENCE: SE209513

TO ORDER BURNDY® PRODUCTS CALL		HYLUG™	
UNITED STATES 1-800-346-4175 (LONDONDERRY, NH)		ITEM NO: N/A	CAT. NO: YA--2N (SEE TABLE)
CANADA: 1-800-361-6975 (QUEBEC) 1-800-387-6487 (ALL OTHER PROVINCES)		DRAWN BY: J MICHAUD 11/18/94	CHECKER: D FILLION 11/18/94
FOR PRODUCT INFO: http://www.burndy.com		DSN APPVL: C PALAGI 10/24/94	MFG APPVL: --
		QA APPVL: C ACKERMAN 11/17/94	MKT APPVL: T NELSON 11/10/94
		PROD FAM: CM&R COMPRESSION	DRAWING NO: SD031189
		PROJECT #: --	SCALE: 1:1
		DOCUMENT TYPE: Sales	REV: C
		REL LEVEL: Released	SHEET 8 OF 10

REV: PEO200