

CONDUCTOR ACCOMMODATION					
CATALOG NO.	RUN	TAP	A	B	C
YG14BTC26	1/4" [6.35mm] THICK STEEL AND COPPER BUSBAR	2/0 AWG FLEX DOWN TO #2 AWG STR COPPER	1.378" [35mm]	.812" [20.6mm]	1.500" [38.1mm]
YG14BTC28	1/8" [3.18mm] - 1/4" [6.35mm] THICK STEEL AND COPPER BUSBAR	4/0 AWG STR TO 1/0 AWG STR COPPER	1.378" [35mm]	.812" [20.6mm]	1.500" [38.1mm]

REV	DATE	DESCRIPTION	ECO	BY	CHK.
F	09/17/2019	REDRAWN IN INVENTOR AND .13 RADIUS ADDED TO THE MODEL	52178	PB	RG

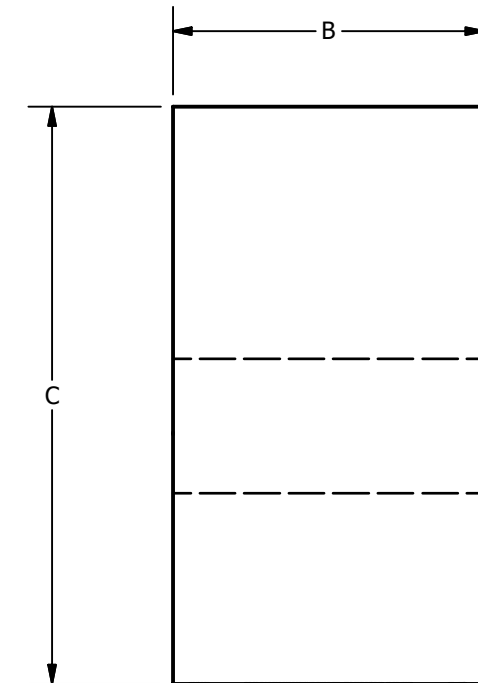
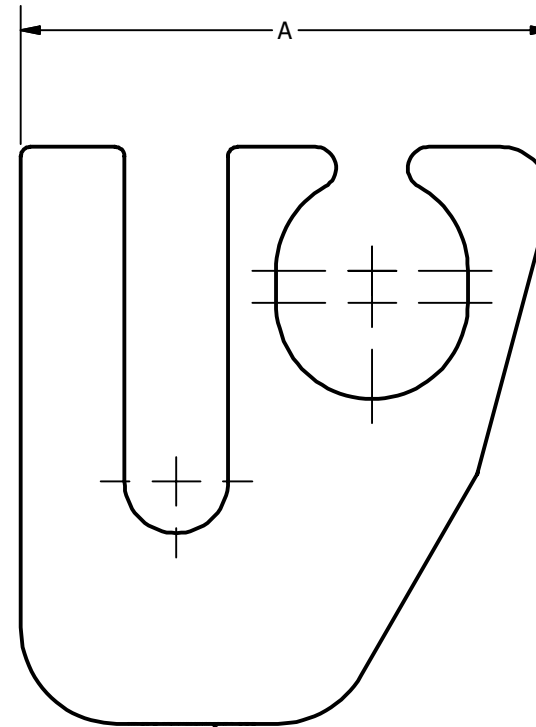
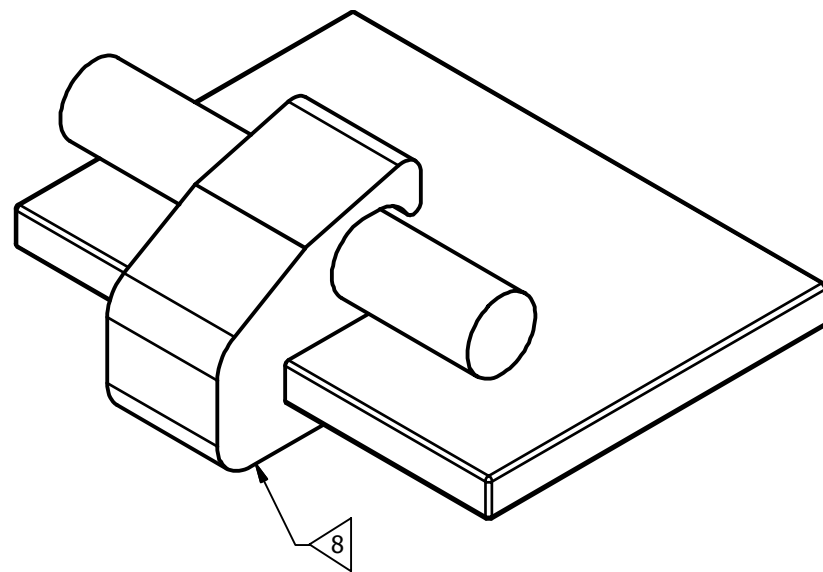

NOTES:

1. MATERIAL: PURE WROUGHT COPPER ALLOY.
2. CONDUCTOR AND BUSBAR GROOVES PREFILLED WITH PENETROX™S4.
3. ACCOMMODATES: SEE TABLE.
4. INSTALLED WITH ONE CRIMP USING THE U1105 DIE SET, WITH THE Y750 (DIE U1105) OR Y46 (DIE P1105) HYPRESS™ SERIES HYDRAULIC TOOL.
5. DIMENSIONS IN BRACKETS [] ARE IN MILLIMETERS ROUNDED TO THE NEAREST MILLIMETER, UNLESS OTHERWISE SPECIFIED, AND ARE FOR REFERENCE ONLY.
6. YG14BTC26 AND YG14BTC26TP ARE cULus (CANADA AND USA) LISTED TO UL467 GROUNDING AND BONDING EQUIPMENT.
YG14BTC28 AND YG14BTC28TP ARE cULus (CANADA AND USA) LISTED TO UL467 GROUNDING AND BONDING EQUIPMENT.

7 TO ORDER TIN PLATED ADD SUFFIX "TP" TO THE END OF THE CATALOG NUMBER. EXAMPLE: YG14BTC28TP

8 IT IS RECOMMENDED TO PRE-CRIMP USING DIE COMBINATION U1BEWP1/U1BEUP1 FOR ADDITIONAL HOLDING STRENGTH.

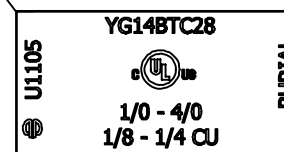

TYPICAL STAMPING

TO ORDER BURNDY® PRODUCTS CALL
 UNITED STATES
 1-800-346-4175 (LONDONDERRY, NH)
 CANADA:
 1-800-361-6975 (QUEBEC)
 1-800-387-6487 (ALL OTHER PROVINCES)
 FOR PRODUCT INFO: <http://www.burndy.com>

BUSBAR CONNECTOR			
ITEM NO: SEE TABLE			
CAT. NO: YG14BTC--TABLE			
DRAWN BY: --			
CHECKER: --			
DSN APRVL: G.DITRIOA 01/01/2001			
MFG APRVL: --			
QA APRVL: J.BRODEUR 01/01/2001			
MKT APRVL: R.ROBICHEAU 01/01/2001	PROJ #:	SIZE:	DRAWING NO:
PROJ #:	SIZE:	SD214246-01	REV:
REL LEVEL: Released	B	SHEET 1 OF 1	F