

REV	DATE	DESCRIPTION	ECO	BY	CHK.
A	11/08/2012	SALES DRAWING REDRAW IN INVENTOR	29204	PM	MB

CONDUCTOR (COPPER)				CATALOG NUMBER	B	BB	H	L APPROX.	O.D.	Q	W	Y	INSTALLATION DATA					
RUN 'A'		TAP 'AA'											INDEX NO.	RUN HYPRESS™ WITH DIE SET WITH NO. OF CRIMPS PER END		INDEX NO.	TAP HYPRESS™ WITH DIE SET WITH NO. OF CRIMPS PER END	
SIZE	STR	SIZE	STR											Y35, Y750	Y60B		Y35, Y750	Y60B
250 Kcmil	19, 37	250 Kcmil	19, 37	YOT2929	1.75	1.84	3.82	7.00	.98	3.31	1.34	1.00	169			169		
		4/0 STR	7,12,19	YOT2928		1.84	3.82	7.00	.98	3.31	1.34	1.00		169				
		1/0 STR	7, 19	YOT2925		1.86	3.32	7.00	.62	2.83	.96	.62		165				
		2/0 STR	7, 19	YOT2926	2.00	4.14	9.50	.72	3.65	1.08	.72	166						
		500 Kcmil	19, 37	YOT2934	3.56	3.00	4.90	12.91	1.41	4.40	1.41	1.16	169			210		
		3 SOL		YOT293W	1.75	1.57	2.98	7.00	.48	2.48	.89	.56	169			163		
																308		
300 Kcmil	19, 37	300 Kcmil	19, 37	YOT3030	1.75	1.75	4.16	7.75	1.07	3.62	1.39	1.11	170			170		
		250 Kcmil	19, 37	YOT3029		1.75	3.92	7.61	.97	3.38	1.34	1.01		169				
		4/0 STR	7, 12, 19	YOT3028		1.75	3.92	7.61	.97	3.38	1.34	1.01		169				
350 Kcmil	12, 19, 37	350 Kcmil	12, 19, 37	YOT3131	2.50	2.50	4.60	10.16	1.18	4.01	1.60	1.22	267			267		
		4/0 STR	7,12,19	YOT3128		1.56	3.74	10.16	.89	3.12	1.35	.93		168				
		2/0 STR	7, 19	YOT3126		1.62	3.92	10.16	.72	3.33	1.14	.75		166				
		1/0 STR	7, 19	YOT3125		1.62	3.92	10.16	.62	3.33	1.09	.70		165				
400 Kcmil	19, 37	400 Kcmil	19, 37	YOT3232	2.81	2.81	4.89	11.12	1.24	4.27	1.68	1.28	209			209		
		4/0 STR	7,12,19	YOT3228		1.56	3.69	10.75	.89	3.06	1.31	.93		168				
500 Kcmil	19, 37	500 Kcmil	19, 37	YOT3434	2.50	2.50	4.82	10.38	1.40	4.12	1.92	1.44	210	U210 (6)	U210 (2)	210	U210 (6)	U210 (2)
		350 Kcmil	12, 19, 37	YOT3431		2.50	4.82	10.38	1.18	4.12	1.71	1.22				267		
		4/0 STR	7,12,19	YOT3428		1.56	3.84	9.88	.89	3.14	1.41	.93				168		
		2/0 STR	7, 19	YOT3426		1.62	4.14	9.70	.72	3.44	1.23	.75				166		
600 Kcmil	37, 61	600 Kcmil	37, 61	YOT3636	2.03	2.21	4.94	10.75	1.55	4.16	1.88	1.35	576			576		
		300 Kcmil	19, 37	YOT3630		1.74	4.47	10.75	1.05	3.69	1.88	1.35		170				
750 Kcmil M.H.D.	37	750 Kcmil M.H.D.	37	YOT3939	3.09	3.46	5.82	12.19	1.70	4.97	2.25	1.73	627			627		

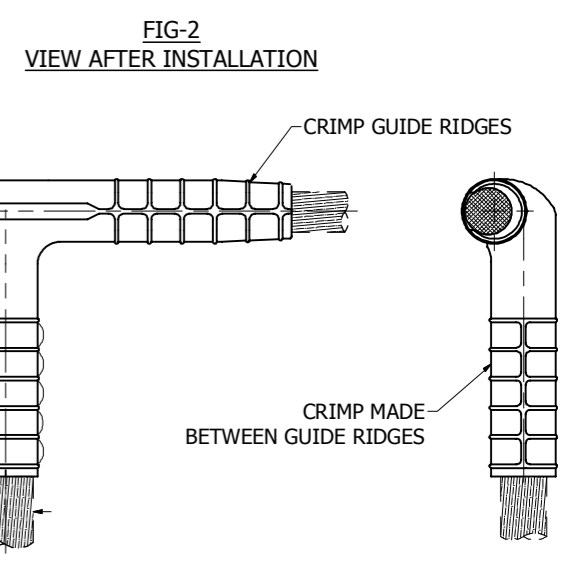
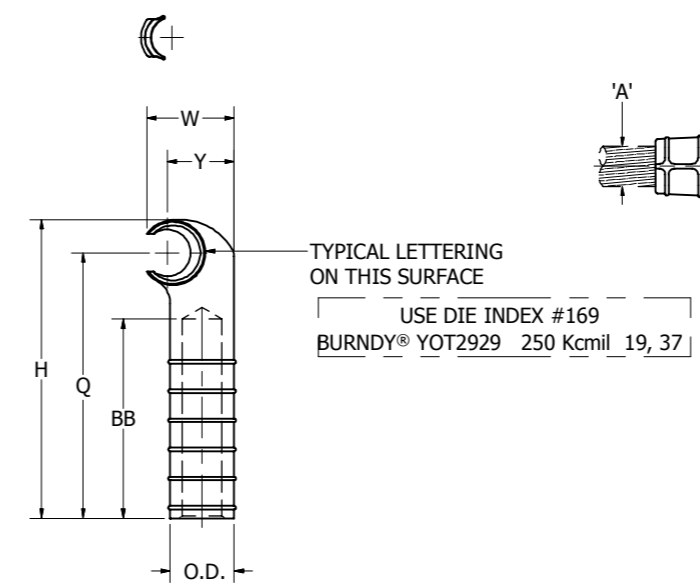
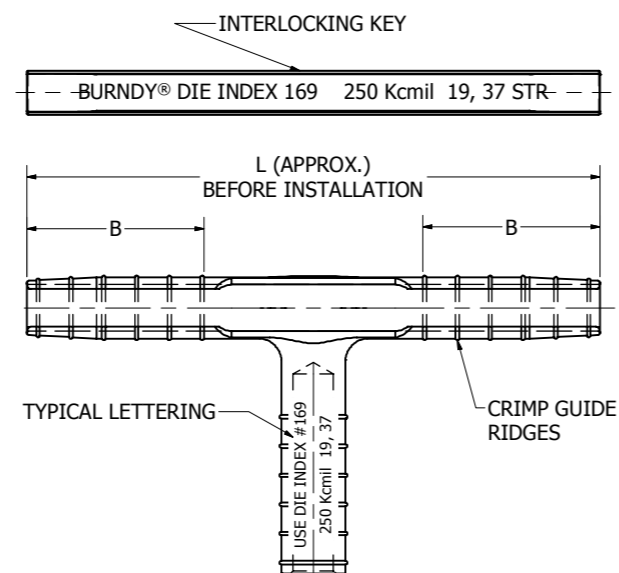

- NOTES:
- INSTALLATION NOTE:
- INDEX #308-2 CRIMPS MADE SIMULTANEOUSLY. INDEX #163-3 CRIMPS MADE SIMULTANEOUSLY, AND WILL OVERLAP.
 - YOT2629 CAN BE INSTALLED ALSO WITH Y60 HYPRESS™. L169 DIE SET FOR RUN, L166 DIE SET FOR TAP.
 - MATERIAL : CAST COPPER ALLOY
 - FINISH : RUN GROOVE AND TAP BARREL LINED WITH BERYLLIUM COPPER PARTICLES.

REFERENCE : SD033889N19
SUPERSEDES : SD024930-13

TO ORDER BURNDY® PRODUCTS CALL UNITED STATES 1-800-346-4175 (LONDONDERRY, NH) CANADA: 1-800-361-6975 (QUEBEC) 1-800-387-6487 (ALL OTHER PROVINCES) FOR PRODUCT INFO: http://www.burndy.com	HYTEE (COPPER)	
	ITEM NO: N/A	
	CAT. NO: SEE TABLE	
	DRAWN BY: P. HARRICK 01/10/1958 CHECKER: W ZAHLMAN 06/05/2014 DSN APRVL: -- MFG APRVL: -- QA APRVL: J HILLMAN 06/09/2014 MKT APRVL: J HALL 07/16/2014	
PROJECT #: -- DOCUMENT TYPE: SALES REL LEVEL: Released	SIZE: D	DRAWING NO: SD024930-01 REV: A SHEET 1 OF 1