

CATALOG NUMBER	STRANDED COPPER CONDUCTOR ACCOMMODATED			BOLT SIZE	METRIC BOLT SIZE	DIMENSIONS								
	CODE (AWG)	NAVY	METRIC SIZE (CLASS 2)			B	C	E	K DIA.	L	N	O.D.	T REF.	Z MIN.
YA8CL2TC10E2	#8 STR	23	-----	#10	----	.44 [11]	.41 [10]	.75 [19]	.21 [5]	1.95 [50]	.25 [6]	.27 [7]	.08 [2]	.26 [7]
YA8CL2TC14				1/4	M6	.44 [11]	.62 [16]	.27 [7]	1.95 [50]	.31 [8]	.08 [2]	.33 [8]		
YA8CL2TC14E2				1/4	M6	.44 [11]	.75 [19]	.27 [7]	2.08 [53]	.31 [8]	.08 [2]	.33 [8]		
YA8CL2TC14E1				1/4	M6	.44 [11]	1.00 [25]	.27 [7]	2.33 [59]	.31 [8]	.08 [2]	.33 [8]		
YA8CL2TC38				3/8	-----	.58 [15]	1.00 [25]	.39 [10]	2.52 [64]	.41 [10]	.06 [2]	.42 [11]		
YA8C2LN				1/2	M12	.44 [11]	.83 [21]	1.75 [44]	.56 [14]	3.75 [95]	.62 [16]	.12 [3]	.64 [16]	

REV	DATE	DESCRIPTION	ECO	BY	C.H.K.
E	2019-11-18 00:00:00 EST	REMOVED CAT. #YA8CL2TC14 FROM TABLE	53047	JL	TR

CONNECTOR SIZE	TOLERANCES						
	B	C	E	K DIA.	L	N	O.D.
-8C THRU -25	±.06	±.04	±.02	±.02	±.09	±.03	±.01
-26 THRU -34	±.08	±.04	±.02	±.02	±.12	±.03	±.01
-35 AND UP	±.09	±.06	±.02	±.02	±.15	±.06	±.01

TOLERANCE BLOCK

CATALOG NO.	COLOR CODE	DIE INFORMATION		MECHANICAL				HYDRAULIC						DIELESS (# CRIMPS)	WIRE STRIP LENGTH		
		DIE INDEX	TYPE	Y1MRTC Y122CMR	OUR840	MD6 MD7	MD6--R2 MD7-34R	PAT600 Y500CT PATMD6	Y34A Y34B Y34BH	Y35,Y39 Y750, PAT750	Y46 PAT46	Y45	Y48B			Y60BHU	
YA8CL2TC10E2 YA8CL2TC14 YA8CL2TC14E2 YA8CL2TC14E1 YA8CL2TC38 YA8C2LN	RED	49	RED DIE SET	RED (1)	X8CRT(1)	W8CVT(1) W8CRT(1)	W8CVT(1) W8CRT(1)	W8CVT(1) W8CRT(1)		5	U8CRT(1)	U8CRT(1)	U8CRT(1)			RATCHET: Y8MRB-1(1) MECHANICAL: MY29-3(1) MY29-11(1) MRC840(1) HYDRAULIC: Y81KFT (1) Y4PC834 (1)	7/16"
			NEST														
			INDENTOR														

- NOTES:
- MATERIAL: COPPER TUBING.
 - FINISH: TIN PLATED.
 - CATALOG # PT6515 ADAPTOR IS REQUIRED TO USE "U" DIES IN Y45 SERIES TOOLS.
 - CATALOG # PUADP-1 ADAPTOR IS REQUIRED TO USE "U" DIES IN Y46 SERIES TOOLS.
 - Y35P3 INDENTOR ADAPTOR REQUIRED FOR Y34PR INDENTOR.
 - PERMANENT DIE IN TOOLING.
 - DIMENSIONS IN BRACKETS [] ARE IN MILLIMETERS ROUNDED OFF TO THE NEAREST MILLIMETER, UNLESS OTHERWISE NOTED, AND ARE FOR REFERENCE ONLY.
 - FOR USE BY CUSTOMERS THAT HAVE THIS HYPRESS™ NO NEW Y34A HYPRESS™ TOOLS ARE BEING PROCESSED. Y34A USES A-D TYPE NEST DIES.
 - CONNECTORS ARE UL LISTED; UNDRILLED VERSIONS ARE NOT UL LISTED.
 - CONNECTORS ARE CSA CERTIFIED; UNDRILLED VERSIONS ARE NOT CSA CERTIFIED.
 - FOR UNDRILLED VERSIONS ADD SUFFIX "-U" TO END OF CATALOG NUMBER. FOR UNDRILLED VERSIONS, USE D MIN. = N MAX. + E MIN. + Z MIN.
 - "X", "W-RT", "W-VT", "U", & "L" DIE SETS ARE COLOR CODED. "A", "B", AND "C" DIES ARE NOT COLOR CODED. NESTS AND INDENTOR TYPE ARE NOT COLOR CODED.
 - FINISH: TIN PLATED. THE FOLLOWING SUFFIXES DENOTE OPTIONAL PLATING TYPES. BR = BARE; LD = LEAD; NK = NICKEL; SV = SILVER. (EXAMPLE: YAV4L2TC14NK)

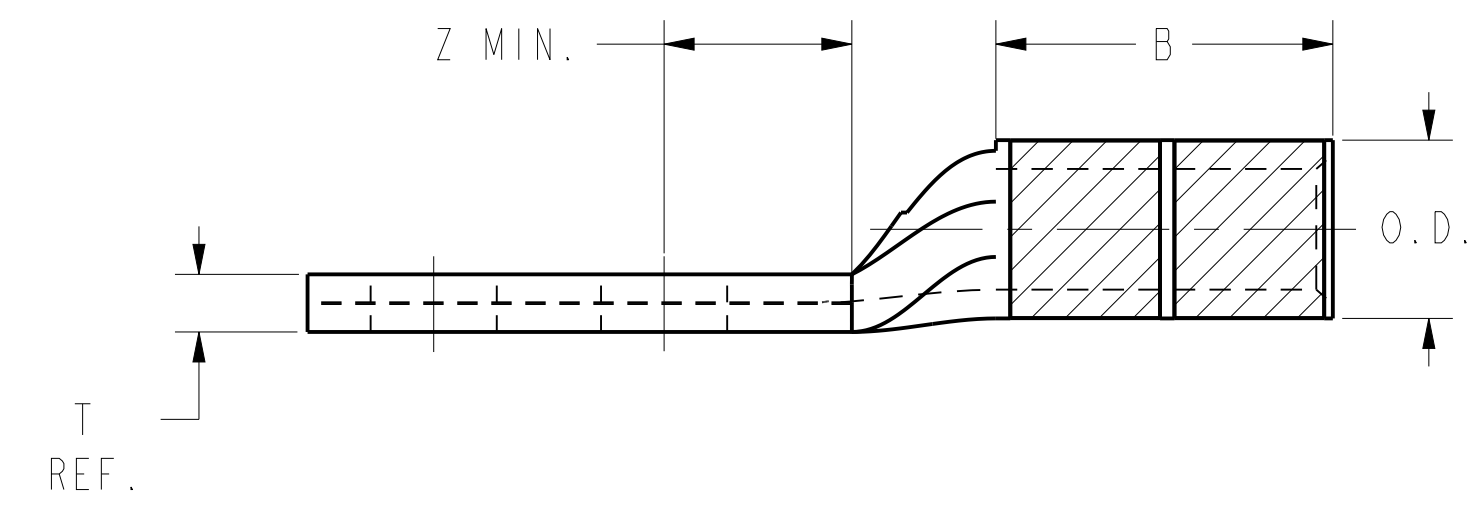
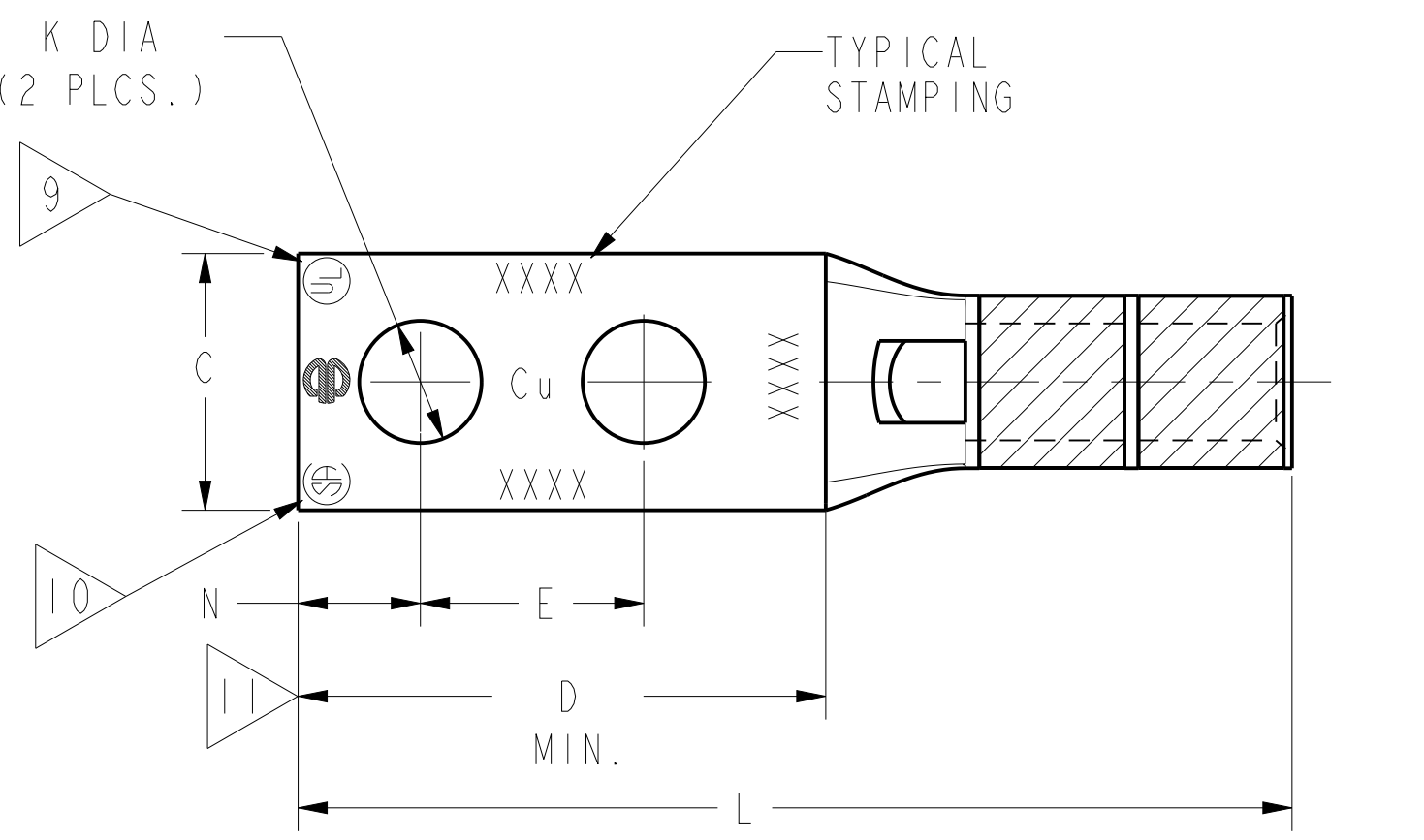

REFERENCE : SE209512
SUPERSEDES : SC91923

TO ORDER BURNDY® PRODUCTS CALL UNITED STATES 1-800-346-4175 (LONDONDERRY, NH) CANADA: 1-800-361-6975 (QUEBEC) 1-800-387-6487 (ALL OTHER PROVINCES) FOR PRODUCT INFO: http://www.burndy.com	COPPER HYLUG™			
	ITEM NO:	N/A		
	CAT. NO:	YA-L-2TC, YA--2NT-, YA-4L (TABLE)		
	DRAWN BY:	C. RACANO	4/15/78	
	CHECKER:	C. A. R.	4/15/78	
	DSN APPVL:	LB.	4/17/78	
	MFG APPVL:	--	--	
	QA APPVL:	C. ACKERMAN	11/17/94	
	MKT APPVL:	T. NELSON	11/10/94	
	PROD FAM:	CM&R COMPRESSION	DRAWING NO	REV
PROJECT #:	--	SIZE	SD035209	
DOCUMENT TYPE:	Sales		E	
REL LEVEL:	Released	D	SHEET 2 OF 18	

REV: PEO200