

REV	DATE	DESCRIPTION	EC	BY	C.H.K.
C	2021-09-21 00:00:00 EDT	DRAWING RELEASED	210921012586	MM	NJS

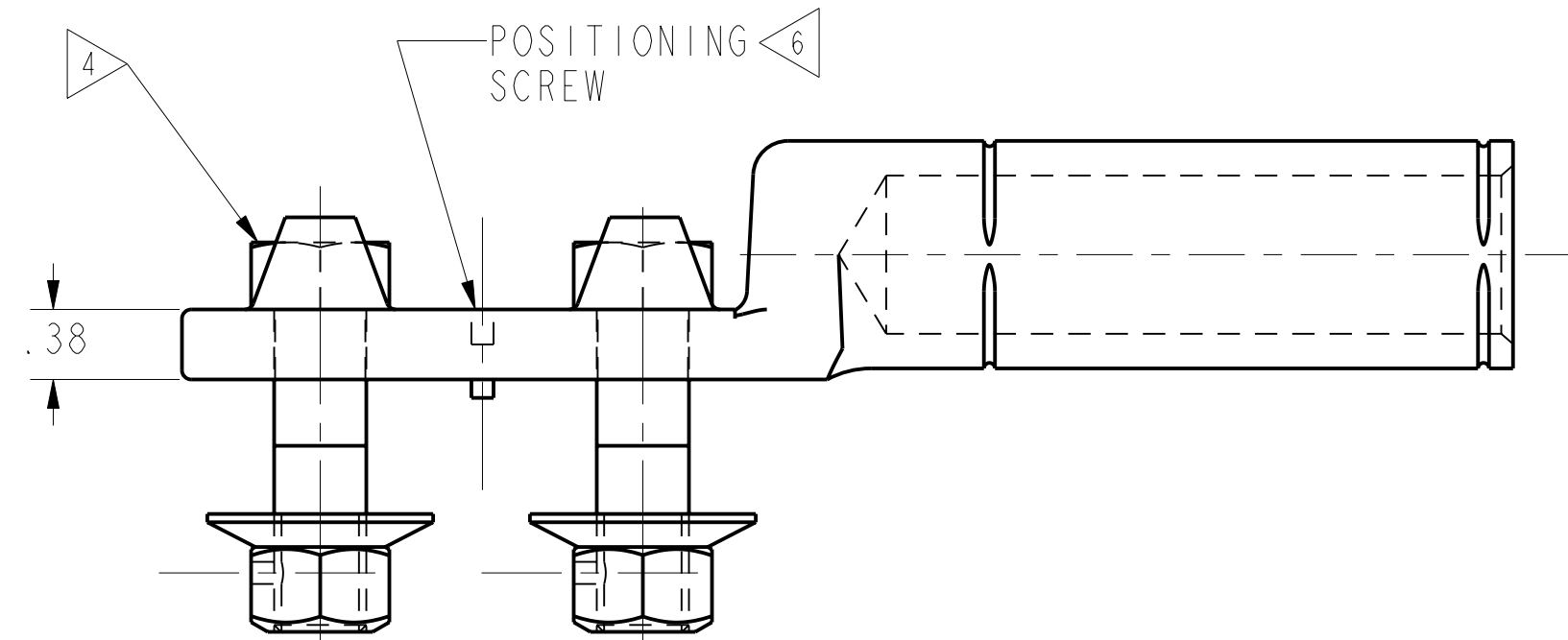
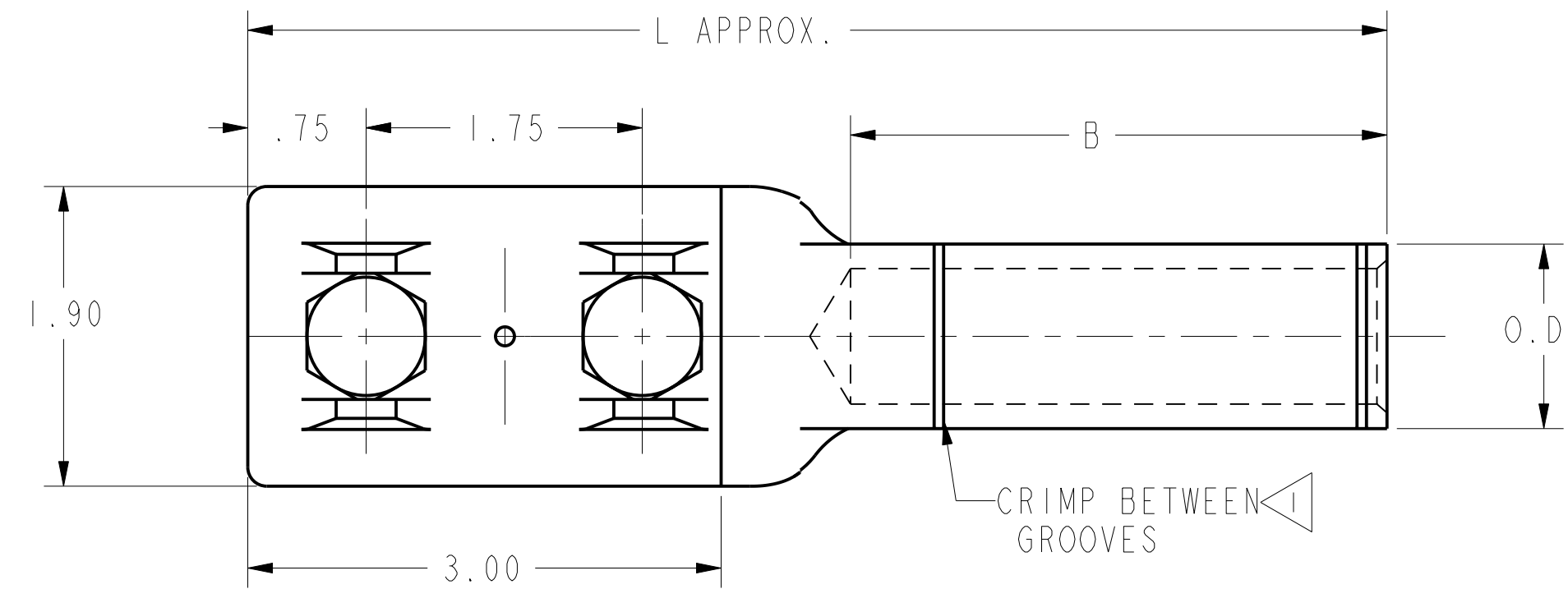

MATERIAL:
CAST ALUMINUM
BARREL PARTIALLY FILLED WITH
"PENETROX" AND SEALED.
TONGUES COATED WITH AN OXIDE RETARDANT.

TYPICAL LETTERING ON CONNECTOR

BURNDY CU. OR AL USE DIE L 705 251 K I 1/8-1 KI
4/0 ACSR 4/0STR
YKA28R-2N

NOTES:

- 1 RECOMMENDED NO. OF CRIMPS LISTED.
- 2 TWO CRIMPS MADE SIMULTANEOUSLY.
- 3 FLAT SIDED BARREL.
- 4 CAPTURED HARDWARE INCLUDED IN CATALOG NUMBER
1/2"-13X1 3/4" LG. ALUM BOLTS & ALUM. CONTACT NUTS (SELF LOCKING).
- 5 SAME AS YKA26R-2N EXCEPT WITH A PAPER LABEL READING ACSR & STR. DIE INDEX 705
- 6 SAME AS YKA28R-2N EXCEPT WITH A PAPER LABEL READING MAY ALSO BE INSTALLED WITH T & B DIE 76.
- 7 SAME AS YKA361R-2N EXCEPT WITH A PAPER LABEL READING: MAY ALSO BE INSTALLED WITH T & B DIE 106 & BURNDY INDEX 719.

INSTALLATION NOTE:

SCRATCH BRUSH CONDUCTOR AND CONNECTOR CONTACT SURFACES DRY, THEN APPLY 'PENETROX-A' (NOT INCLUDED IN CAT.NO.) CAN BE PURCHASED FROM THE BURNDY CORP. IN CANS OR PLASTIC SQUEEZE BOTTLES.

- 5 USE BURNDY HYPRESSES
a) Y48B & DIE SET C45RYF OR C451RYF.
b) Y486RB & DIESET F45RYF.
- 6 SCREW MAY BE REMOVED FOR USE ON STANDARD TERMINAL PADS.

TO ORDER BURNDY@PRODUCTS CALL UNITED STATES: 1-800-346-4175 (LONDONDERRY, NH)		CANADA: 1-800-361-6975 (QUEBEC) 1-800-387-6487 (ALL OTHER PROVINCES)		FOR PRODUCT INFO: http://www.burndy.com	
HYLUG (CU. ACSR)					
ITEM NO: ----					
CAT. NO: YKA-R-2N, YKA-42-N, YKA-R-2NG (TABLE)					
DRAWN BY: JMC					
CHECKER: --					
DSN APPVL: S RALPHS 02/08/22					
MFG APPVL: B MERRITT 10/08/21					
QA APPVL: J BRODEUR 10/08/21					
MKT APPVL: --					
PROD FAM: --				SCALE: 1:1	
PROJECT #: --				DRAWING NO	
DOCUMENT TYPE: Sales				SD051205	
REL LEVEL: Released				SHEET 1 OF 3	

REV: CREO 08/10/21

REV	DATE	DESCRIPTION	EC	BY	C'H'K.
C	2021-09-21 00:00:00 EDT	DRAWING RELEASED	210921012586	MM	NJS

D

D

CONDUCTOR RANGE						CAT. NO.	B	L	O.D.	INSTALLATION DATA \triangleleft								REFERENCE	REV.	
ACSR		COPPER		ALUM.						TOOL INDEX NO.	BURNDY DIE SET & NO. OF CRIMPS				KEARNEY DIE SETS & NO. OF CRIMPS					
AWG. Kcmil	STR	AWG. Kcmil	STR	AWG. Kcmil	STR						MD6 HYTOOL		Y35 HYPRESS		'U' TYPE HAND TOOL		WH2 TYPE PRESS			
-----	---	#8 STR. (.146) #6 SOL. (.162)	7 1	#8 STR (.146) #6 SOL (.162)	7 1	YKA6WA2N														
#6 STR. (.198)	6-1	#6 STR. (.184) #4 SOL. (.204) #5 STR. (.206)	7 1 7	#6 STR (.184) #4 SOL (.204) #5 STR (.206)	7 1 7	YKA4WA2N	1.68	5.51	.65	B-G OR 243	GROOVE BG W243	8 4	U2YLMT U2YLCMT U25RYFT	6 2 \triangleleft	5/8-1	8	5/8-1	4	PC51216	9
#4 STR (.250) (.257)	6-1 7-1	#4 STR. (.232) #2 SOL. (.258) #3 STR. (.260)	7 1 7	#4 STR. (.232) #2 SOL. (.258) #3 STR. (.260)	7 1 7	YKA2WA2N														
#2 STR (.316) (.325)	6-1 7-1	#1 STR. (.328) #2 STR (.292) (.320)	7 7 3	#1 STR. (.328) #2 STR (.292)	7 7	YKA2R2N														2
1/0 STR. (.398)	6-1	1/0 STR. (.368) (.390) (.373)	7 12 19	1/0 STR. (.368) (.373)	7 19	YKA25R2N	1.64	5.56	.80	C 65B OR 247	W-C W247	8 4	U2YCMT U26RLYRT U247	6 2 \triangleleft 2	.737	8	737	4	PC51217	13
2/0 STR. (.447)	6-1	2/0 STR. (.414) (.438) (.419)	7 12 19	2/0 STR. (.414) (.419)	7 19	YKA26R2N YKA25R2NG3 \triangleleft														14 16
3/0 STR. (.502) 110.8 (.481)	6-1 12-7	3/0 STR. (.464) (.492) (.470)	7 12 19	3/0 STR. (.464) (.470)	7 19	YKA27R2N	1.97	6.02	1.06	L 251 OR 705	W-L	4	U28YTT U30RYFT	2 3	NONE	---	1" OR 1 1/8-1	2	PC51209	14
4/0 STR. (.563)	6-1	4/0 STR. (.522) (.552) (.528)	7 12 19	4/0 STR. (.522) (.528)	7 19	YKA28R2N YKA28R2NG3 \triangleleft							U705	2						14 16
266.8 (.609) (.633) (.642)	18-1 6-7 26-7	250 (.600) (.575) 300 (.628) (.630)	12 19,37 19 37	250 (.575) (.586) 266.8 (.593) 300 (.629) (.631)	37 7 19 37 61	YKA30R2N														
336.4 (.684) 300 (.680)	18-1 26-7	350 (.678) (.681)	19 37	350 (.681)	37,61	YKA321R2N	3.06	7.22	1.24	M 317 OR 705	NONE	---	U33YTT U35RYFT	3 4	NONE	---	1 1/4 OR 1 1/8-1	3	PC51218	14
336.4 (.721) (.741) 397.5 (.748)	26-7 30-7 18-1	-----	---	397.5 (.724) 400 (.728)	19 37	YKA33R2N			\triangleleft											14 14
392.5 (.721) (.806) 477 (.814)	26-7 30-7 18-1	-----	---	477 (.795) 500 (.815)	19,37 37,61	YKA361R2N YKA861R2NG3 \triangleleft							U705	3	NONE	---	1 8/16 OR 1 1/8-1	3	PC51915	14 16
477 (.846) (.858) (.883)	24-7 26-7 30-7	-----	---	556.5 (.256) (.858)	19 37	YKA37R2N	3.06	7.33	1.36	M OR 318	NONE	---	U33YTT U37RYFT	3 4	NONE	---	1 5/16	3	PC51219	14
397.5 (.783) (.806) 477 (.814)	26-7 30-7 18-1	500 (.811) (.813)	19 37	477 (.795) 500 (.815)	19,37 37,61	YKA34CA2N	5.25	9.42	1.84 \triangleleft					3	NONE	---	NONE	---	PC52049	16

C

C

B

B

A

A

REV: CREO 08/10/21

TO ORDER BURNDY@PRODUCTS CALL		HYLUG (CU. ACSR)	
UNITED STATES: 1-800-346-4175 (LONDONDERRY, NH)		ITEM NO: -----	SCALE: 1:1
CANADA: 1-800-361-6975 (QUEBEC) 1-800-387-6487 (ALL OTHER PROVINCES)		CAT. NO: YKA-R-2N, YKA-42-N, YKA-R-2NG (TABLE)	
FOR PRODUCT INFO: http://www.burndy.com		DRAWN BY: JMC	
		CHECKER: --	
		DSN APPVL: S RALPHS 02/08/22	
		MFG APPVL: B MERRITT 10/08/21	
		QA APPVL: J BRODEUR 10/08/21	
		MKT APPVL: --	
		PROD FAM: --	DRAWING NO
		PROJECT #: --	SD051205
		DOCUMENT TYPE: Sales	C
		REL LEVEL: Released	SHEET 2 OF 3

REV	DATE	DESCRIPTION	EC	BY	C'H'K.
C	2021-09-21 00:00:00 EDT	DRAWING RELEASED	210921012586	MM	NJS

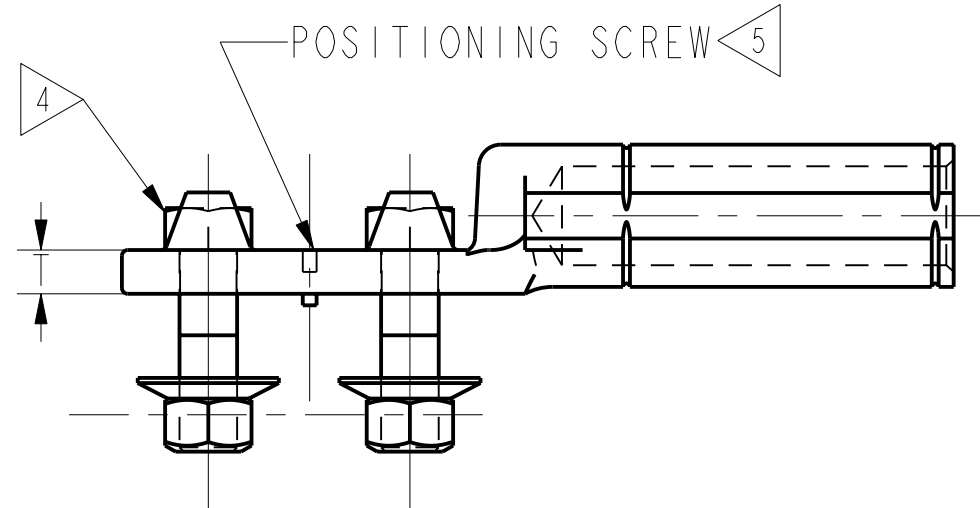
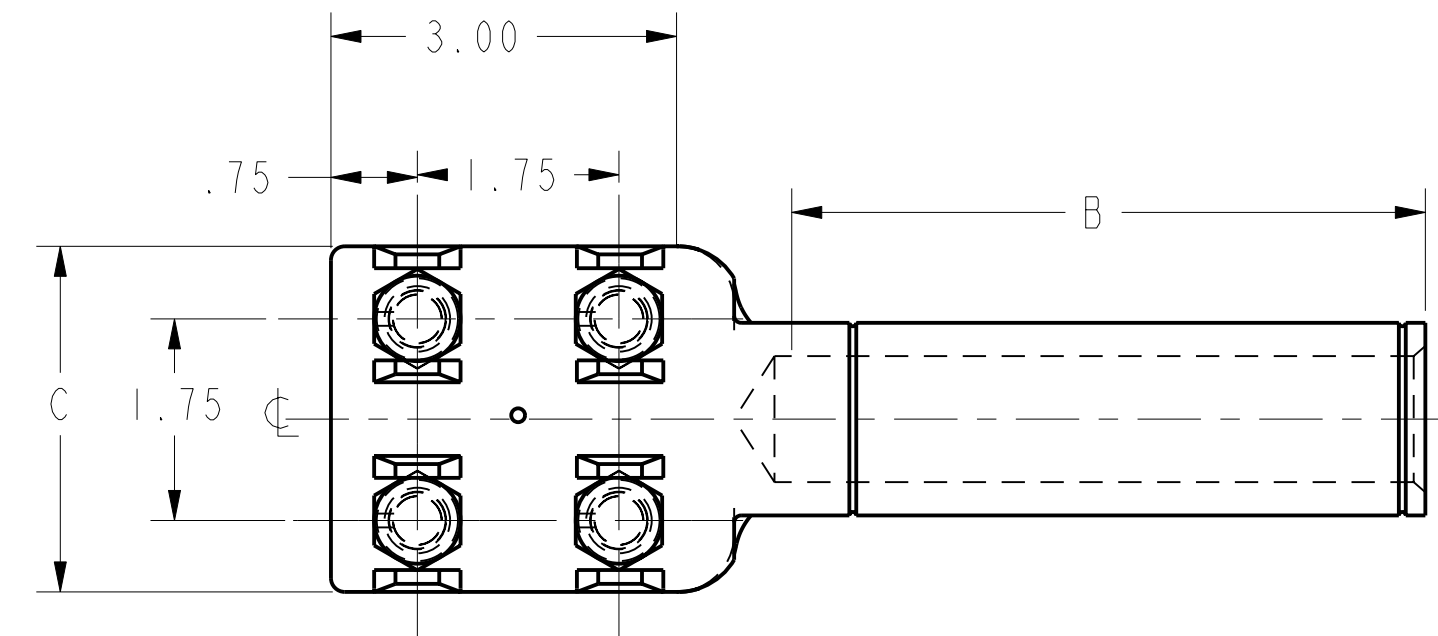
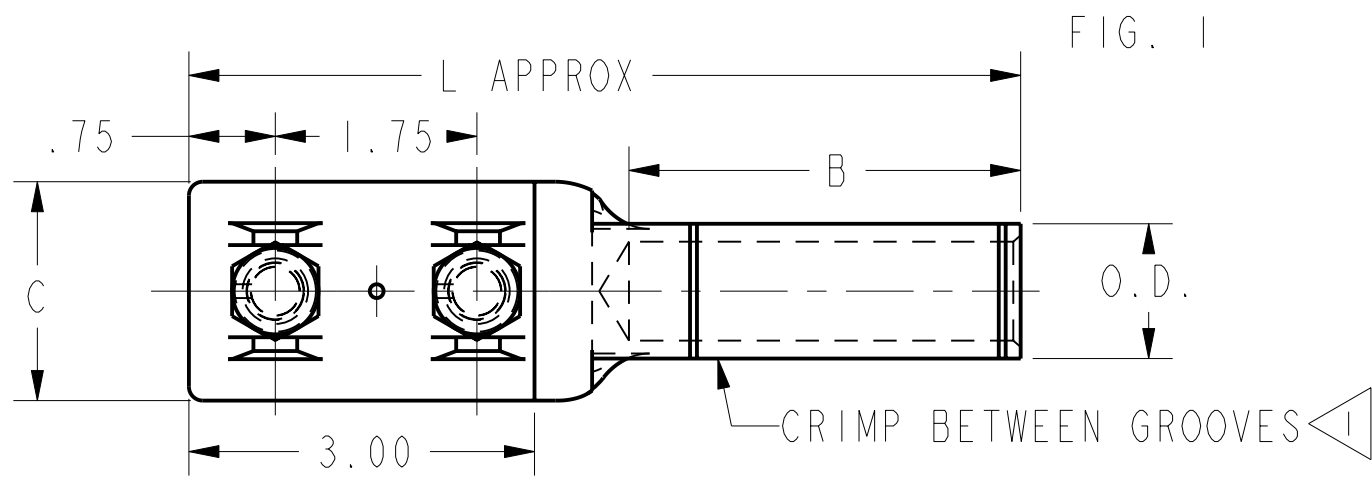

FIG. 2

TYPICAL LETTERING ON CONNECTOR
 BURNDY CU OR AL USE DIE 251/L/1"
 4/0 ACSR 4/0 STR
 YKA28R2N

FIG. NO.	CONDUCTOR RANGE						CAT. NO	B	C	L	O.D.	T	BOLT LENGTH	INSTALLATION DATA										REFERENCE	REV.			
	ACSR		COPPER		ALUM.									TOOL INDEX NO.	BURNDY TOOL, DIE SET & NO. OF CRIMPS						YEARNEY DIE SET & NO. OF CRIMPS							
	AWG. Kcmil	STR	AWG. Kcmil	STR	AWG. Kcmil	STR									MD6 HYTOOL	Y35 HYPRESS	Y48B HYPRESS	Y486RB HYPRESS	'O' TYPE HAND TOOL	WH-2 TYPE PRESS								
1	605 (.994) 636 (.977) 636 (.990) 636 (1.019) 666.6 (1.000)	30-19 24-7 26-7 30-19 24-7	-----	---	795 (1.026) 795 (1.028)	37 61	YKA43R2N	5.25	3.00	9.52	1.84	.56	2.25	292 578 OR 319	---	---	---	---	C412RYF1 C43RYF	3	F412RYF1 F43RYF	3	-----	---	---	---	PC57701	11
1	-----	---	-----	---	795 (1.026) 795 (1.028)	37 61	YKA391A2N YKA391A4NG1	5.25	3.00	9.50	1.67	.56 .38	2.25 1.75	342	---	---	-----	---	C391AYD	3	-----	---	-----	---	-----	---	PC54316	11
1	-----	---	350 (.678) 350 (.681)	19 37	350 (.678) 350 (.681)	19 37	YKA31CA2N	3.06	1.90	7.33	1.36	.38	1.75	M OR 318	---	---	U33YTT U37RYFT	3 4	---	---	---	---	NONE	1 5/16	3	PC51219	11	
1	556.5 (.927) (.914)	26-7 24-7	-----	---	-----	---	YKA39R2N	3.59	1.90	7.81	1.50	.38	1.75	608	---	---	U39RYFT	6	C39RYF	2	F39RYF	2	-----	---	---	---	PC56205	12
1	795 (1.108) (1.093)	26-7 54-7	-----	---	900 (1.094) 927 AL .5005 (1.108) 954 (1.126)	61,91 37 37,61	YKA45R2N	5.25	3.00	9.50	1.84	.56	2.25	352 579 725	---	---	-----	---	C45RYF C725	3	F45RYF F725	3	T & B DIE 150				---	17

MATERIAL:
 CAST ALUMINUM
 BARREL PARTIALLY FILLED WITH
 "PENETROX" AND SEALED
 TONGUES COATED WITH AN OXIDE RETARDANT.

INSTALLATION NOTE:
 SCRATCH BRUSH CONDUCTOR AND CONNECTOR
 CONTACT SURFACES DRY, THEN APPLY
 'PENETROX-A' (NOT INCLUDED IN CAT. NO.), CAN
 BE PURCHASED FROM THE BURNDY CORP.
 IN CANS OR PLASTIC SQUEEZE BOTTLES.

- NOTES:
- 1 RECOMMENDED NO. OF CRIMPS LISTED.
 - 2 TWO CRIMPS MADE SIMULTANEOUSLY.
 - 3 FLAT SIDED BARREL.
 - 4 CAPTURED HARDWARE INCLUDED IN CATALOG NUMBER 1/2"-13 x (BOLT LENGTH) ALUM BOLTS & ALUM. CONTACT NUTS (SELF LOCKING).

5 SCREW MAY BE REMOVED FOR USE ON
 STANDARD TERMINAL PADS.

TO ORDER BURNDY@PRODUCTS CALL UNITED STATES: 1-800-346-4175 (LONDONDERRY, NH) CANADA: 1-800-361-6975 (QUEBEC) 1-800-387-6487 (ALL OTHER PROVINCES) FOR PRODUCT INFO: http://www.burndy.com		HYLUG (CU. ACSR)	
ITEM NO: ----	CAT. NO: YKA-R-2N, YKA-42-N, YKA-R-2NG (TABLE)	DRAWN BY: JMC	CHECKER: --
DSN APPVL: S RALPHS 02/08/22	MFG APPVL: B MERRITT 10/08/21	QA APPVL: J BRODEUR 10/08/21	MKT APPVL: --
PROD FAM: --	PROJECT #: --	SIZE: D	SCALE: 1:1
DOCUMENT TYPE: Sales	REL LEVEL: Released	DRAWING NO: SD051205	REV: C
		SHEET 3 OF 3	

REV: CREO 08/10/21