

CATALOG. NO.	CONDUCTORS						FIG. NO.
	COPPER		ALUM.		ACSR		
	AWG. kcmil	STR	AWG. kcmil	STR	AWG. kcmil	STR	
YCAK26R2G2	2/0	7	2/0	7	2/0	6 - 1	1
YCAK26R4G1		19		19			2
YCAK28R2G9	4/0	7	4/0	7	4/0	6 - 1	1
YCAK291R4G1	250	7, 19 37	250 266.8	7, 19	266.8	18 - 1	2
YCAK30R2G3				37			
YCAK30R4G1	300	19 37	300 336.4	19	266.8	26 - 7	1
YCAK341R2G1							2
YCAK341R4G1	--	--	400	19 37	336.4 397.5	30 - 7	1
YCAK361R2G2	--	--	477 500	19, 37	397.5 477	26 - 7 30 - 7	1
YCAK361R4G1				37, 61		18 - 1	2
YCAK37R2G2	--	--	556.5 600	19, 37	477 556.5	24 - 7 26 - 7 30 - 7	1
YCAK37R4G1				37, 61		18 - 1	2
YCAK25RG4	1/0	7, 19	1/0	7, 19	1/0	6 - 1	3
YCAK26RG2	2/0	7, 19	2/0	7, 19	2/0	6 - 1	
YCAK27RG2	3/0	7, 19	3/0	7, 19	3/0	6 - 1	
YCAK28RG2	4/0	7, 19	4/0	7, 19	4/0	6 - 1	
YCAK291RG1	250	7, 19 37	250 266.8	7, 19, 37	266.8	18 - 1	
YCAK30RG2				7, 19			
YCAK32RG1	350	19, 37	350 397.5	19, 37	336.4	18 - 1	
YCAK341RG1				19		26 - 7	
YCAK361RG4	--	--	477 500	19, 37	397.5 477	26 - 7 30 - 7	
YCAK37RG1				37, 61		18 - 1	
YCAK2RG2	1/0 SOL.	--	1/0 SOL.	--	#2	7 - 1	

CATALOG. NO.	INSTALLATION DATA				
	TOOL INDEX NO.	BURNDY HYPRESS™ AND DIE SET			KEARNEY WH-2 PRESS
		Y35	Y48B	Y60	
YCAK2R-G2 THRU YCAK37R-G1	317 OR 705	U317 U705	C317 --	L317 --	1 1/8 - 1

NOTES:

- ADDITIONAL TOOLING AVAILABLE HYPRESS™ Y486RB AND DIES.
- BARREL PARTIALLY FILLED WITH PENETROX™ AND SEALED.
- TONGUE COATED WITH AN OXIDE RETARDANT.
- OVERLAP CRIMPS.
- MATERIAL: CAST ALUMINUM ALLOY.
- DIMENSIONS IN BRACKETS [] ARE IN MILLIMETERS ROUNDED OFF TO THE NEAREST MILLIMETER, UNLESS OTHERWISE SPECIFIED AND ARE FOR REFERENCE ONLY.

REV	DATE	DESCRIPTION	ECO	BY	CHK.
A	11/07/2012	DRAWING REDRAWN TO INVENTOR	29334	AT	MB

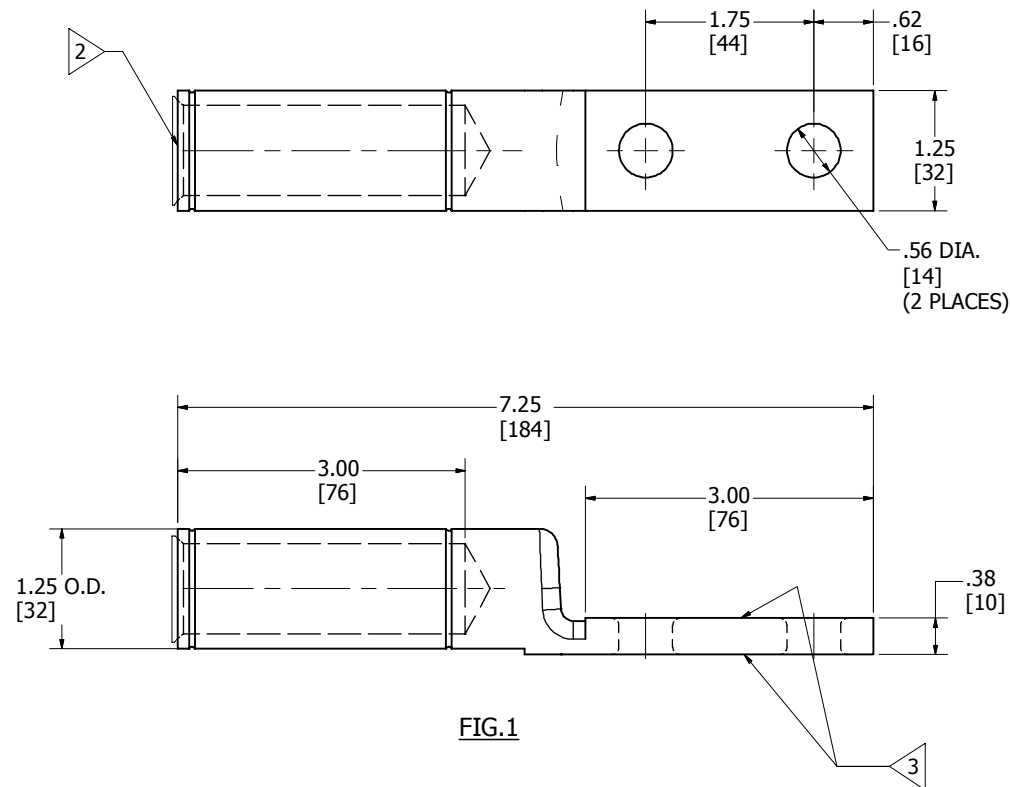

FIG.1

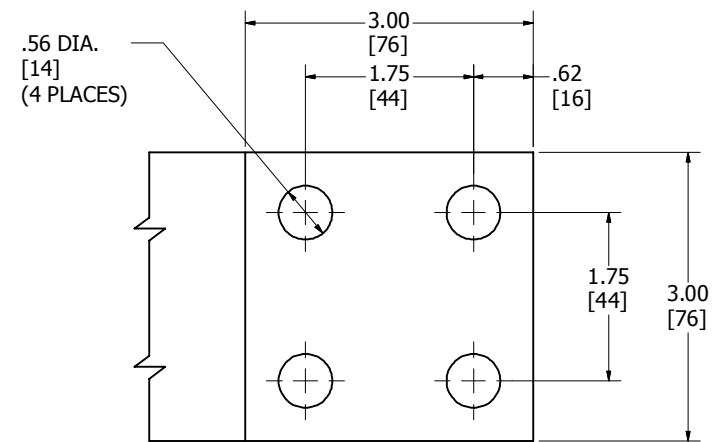

FIG.2

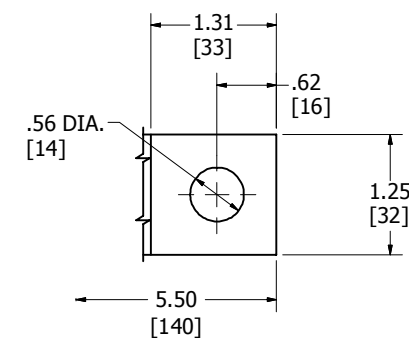

FIG.3

REFERENCE: PD059855

TO ORDER BURNDY® PRODUCTS CALL		ALUM. HYLUG™	
UNITED STATES 1-800-346-4175 (LONDONDERRY, NH)		ITEM NO: N/A	
CANADA: 1-800-361-6975 (QUEBEC) 1-800-387-6487 (ALL OTHER PROVINCES)		CAT. NO: YCAK-R-G (TABLE)	
FOR PRODUCT INFO: http://www.burndy.com		DRAWN BY: A.P. 04/23/1965	
		CHECKER: M.J.M. 04/27/1965	
		DSN APRVL: R.G.H. 04/28/1965	
		MFG APRVL: --	
		QA APRVL: --	
		MKT APRVL: --	
PROD FAM: CM&R COMPRESSION		DRAWING NO	REV
PROJECT #: --		SIZE	SD058715-01
DOCUMENT TYPE: SALES		REL LEVEL: Released	A
		SHEET 1 OF 1	