

CATALOG. NO.	CONDUCTOR						FIG. NO.	O.D.	B	L	T	INSTALLATION DATA									
	COPPER		ALUM.		ACSR							TOOL INDEX NO.	BURNDY HYPRESS™ AND DIE SET ³			KEARNEY WH-2 PRESS					
	AWG. kcmil	STR	AWG. kcmil	STR	AWG. kcmil	STR							Y35	Y48B	Y60						
YCAK25R2G7	1/0	7 19	1/0	7 19	1/0	6 - 1	1	1.25 [32]	3.00 [76]	7.25 [184]	.38 [10]	317 OR 705	U317	C317	L317	1 1/8 - 1					
YCAK27R2G2	3/0	7 19	3/0	7 19	3/0	6 - 1							U705	--	L705						
YCAK291R2G1	250	7, 19 37	250 266.8	7, 19 37	266.8	18 - 1							1.61 [41]	4.30 [109]	8.57 [218]	.50 [13]	724	--	--	L724	1 1/2
YCAK32R2G1	350	19 37	350 397.5	19, 37 19	336.4	18 - 1 26 - 7															
YCAK351U2G1	500	19 37	500 556.5	37, 61 19, 37	477	18 - 1 26 - 7															
YCAK43R2NG4	--	--	700 800	37, 61 37, 61	605 666.6	24 - 7 26 - 7							2	1.25 [32]	3.00 [76]	7.25 [184]	.38 [10]	317 OR 705	U317	C317	L317
YCAK25R4G1	1/0	7 19	1/0	7 19	1/0	6 - 1	U705	--	L705												
YCAK27R4G1	3/0	7 19	3/0	7 19	3/0	6 - 1	1.61 [41]	4.30 [109]	8.57 [218]	.50 [13]	724	--							--	L724	1 1/2
YCAK28R4G2	4/0	7 19	4/0	7 19	4/0	6 - 1															
YCAK32R4G1	350	19 37	350 397.5	19, 37 19	336.4	18 - 1 26 - 7															
YCAK351U4G1	500	19 37	500 556.5	37, 61 19, 37	477	18 - 1 26 - 7															

REV	DATE	DESCRIPTION	ECO	BY	CHK.
A	11/07/2012	DRAWING REDRAWN TO INVENTOR	29334	AT	MB

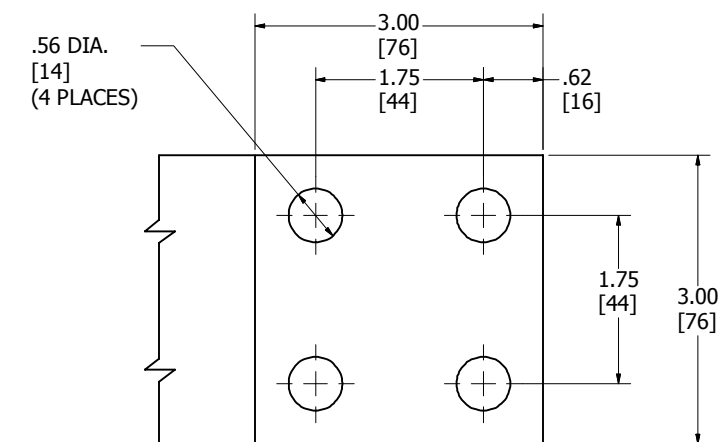
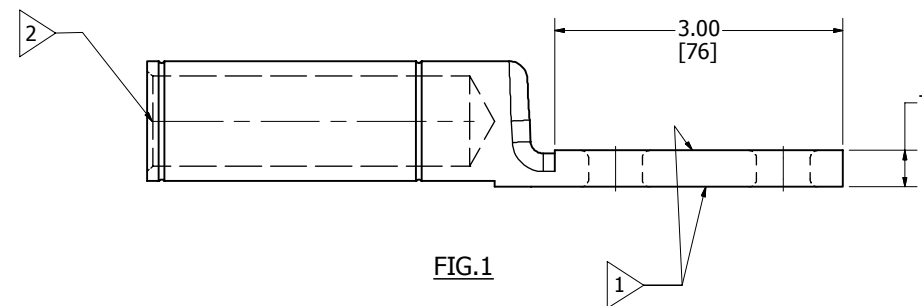
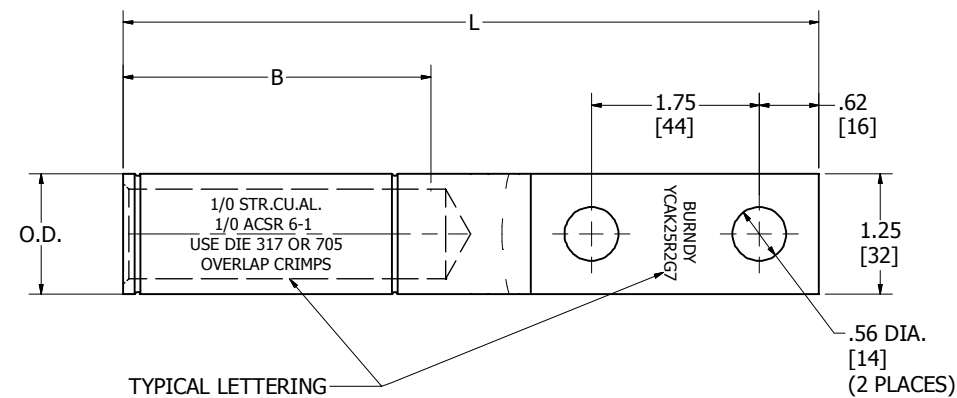

FIG.2

NOTES:

- 1 TONGUE COATED WITH AN OXIDE RETARDANT.
- 2 BARREL PARTIALLY FILLED WITH PENETROX™ AND SEALED.
- 3 OVERLAP CRIMPS.
4. MATERIAL: CAST ALUMINUM EC.
5. DIMENSIONS IN BRACKETS [] ARE IN MILLIMETERS ROUNDED OFF TO THE NEAREST MILLIMETER, UNLESS OTHERWISE SPECIFIED AND ARE FOR REFERENCE ONLY.

TO ORDER BURNDY® PRODUCTS CALL		ALUM. HYLUG™	
UNITED STATES 1-800-346-4175 (LONDONDERRY, NH)		ITEM NO: N/A	
CANADA: 1-800-361-6975 (QUEBEC) 1-800-387-6487 (ALL OTHER PROVINCES)		CAT. NO: YCAK-R--G-, YCAK-U--G- (TABLE)	
FOR PRODUCT INFO: http://www.burndy.com		DRAWN BY: H.C. 09/14/1966	
		CHECKER: M.J.M. 09/20/1966	
		DSN APRVL: -- 09/28/1966	
		MFG APRVL: --	
		QA APRVL: --	
		MKT APRVL: --	
PROD FAM: CM&R COMPRESSION		DRAWING NO	REV
PROJECT #: --		SIZE	SD062358-01
DOCUMENT TYPE: SALES		REL LEVEL: Released	A
		SHEET 1 OF 1	