

REV	DATE	DESCRIPTION	ECO	BY	CHK.
A	10/08/2012	*** DRP*** DRAWING REDRAW PROCESS	28979	BD	MB

ACCOMMODATES		CAT. NO. <sup>2</sup>	SEALING METHOD	FIG.	B	C	D	L	T	EEI DIE INDEX	INSTALLATION DATA					
CONDUCTOR	INS. O.D. <sup>1</sup>										HYTOOL™		HYPRESS™ & DIE SET WITH NO. OF CRIMPS			
											MD6 - 8		Y35	Y34A		
500 Kcmil (.813) CU. CABLE	--	RYA34C2	HEAT SHRINK SLEEVE	1A	2.25 [57]	1.52 [39]	1.06 [27]	3.62 [92]	.23 [6]	--	--	--	U34RT	4	A34R	4
	.810 - 1.188 [21] - [30]	RYA34CR2	FORCE FIT SLEEVE	2A									K1 1/8	2		
350 Kcmil (.681) CU. CABLE	--	RYA31C2	HEAT SHRINK SLEEVE	1A	2.25 [57]	1.52 [39]	1.06 [27]	3.75 [95]	.25 [6]	--	--	--	U34RT	4	A34R	4
	.810 - 1.188 [21] - [30]	RYA31CR2	FORCE FIT SLEEVE	2A									K1 1/8	2		

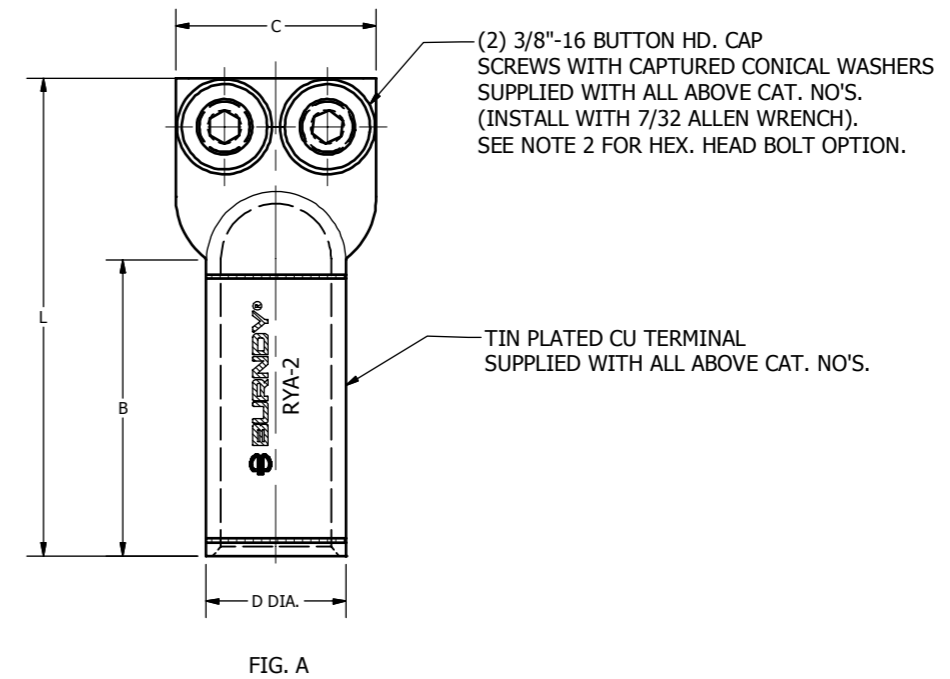
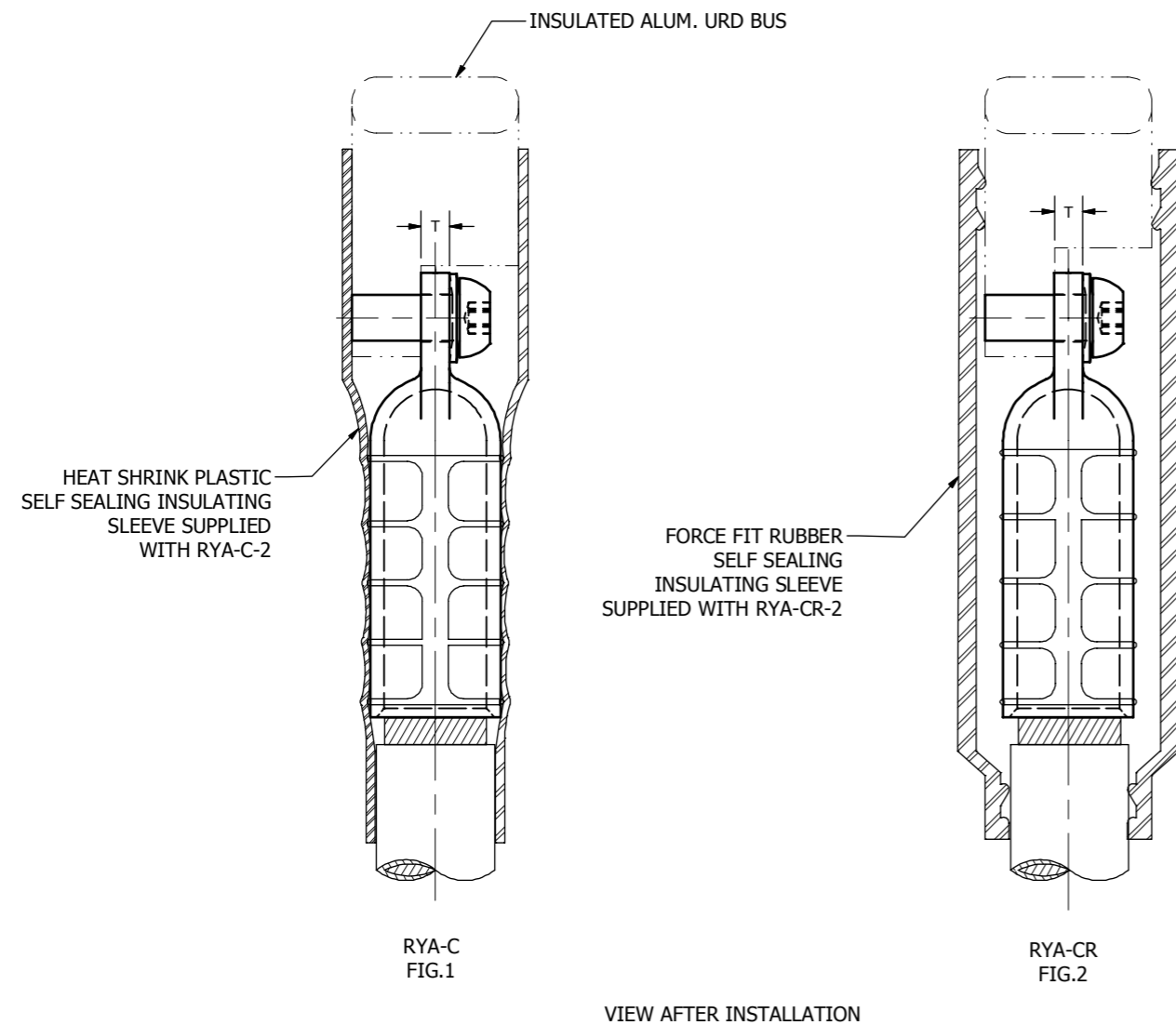

FOR USE WITH  
RDM 5-28T  
RDM 7-28T

SUPERSEDES: SC063936-2

REFERENCE: FD066505, SD063626, PC063546,  
PD066504, FD063719

NOTES:

- CONDUCTOR INSULATIONS WITH SMOOTH ROUND DIAMETERS.
- HEX. HEAD BOLT WITH CAPTURED CONICAL WASHER MAY BE PURCHASED AS AN OPTION BY ADDING "HEX" SUFFIX TO THE CAT. NO. (FOR EX. RYA34C2HEX)
- DIMENSIONS IN BRACKETS [ ] ARE IN MILLIMETERS ROUNDED OFF TO THE NEAREST MILLIMETER, UNLESS OTHERWISE SPECIFIED AND ARE FOR REFERENCE ONLY.

TO ORDER BURNDY® PRODUCTS CALL		URD MOLE TAP ASS'Y	
UNITED STATES 1-800-346-4175 (LONDONDERRY, NH)		ITEM NO: N/A	
CANADA: 1-800-361-6975 (QUEBEC) 1-800-387-6487 (ALL OTHER PROVINCES)		CAT. NO: RYA-C-2	
FOR PRODUCT INFO: <a href="http://www.burndy.com">http://www.burndy.com</a>		DRAWN BY: H.C 6/11/1968	
		CHECKER: MJM 10/17/1968	
		DSN APRVL: FID 6/19/1968	
		MFG APRVL: --	
		QA APRVL: --	
		MKT APRVL: --	
		PROD FAM: --	
		DRAWING NO	
		SD063936-01	
		REV	
		A	
		SHEET 1 OF 1	