

REV	DATE	DESCRIPTION	ECO	BY	CHK.
A	11/07/2012	DRAWING RELEASED	29204	PM	MB

RUN		TAP		CATALOG NUMBER	FIG.	RUN			TAP			INSTALLATION DATA, RUN				INSTALLATION DATA, TAP				LABEL LETTERING			
CODE NAME	MM <sup>2</sup>	CODE NAME	MM <sup>2</sup>			I.D. (MM)	O.D. (MM)	L (MM)	I.D. (MM)	O.D. (MM)	B (MM)	H (MM)	DIE INDEX	MD 6-8 HYTOOL™		Y35 HYPRESS™		DIE INDEX	MD 6-8 HYTOOL™		Y35 HYPRESS™		
														DIE SET & NO. OF CRIMPS PER END	DIE SET & NO. OF CRIMPS PER END	DIE SET & NO. OF CRIMPS PER END	DIE SET & NO. OF CRIMPS PER END		DIE SET & NO. OF CRIMPS PER END		DIE SET & NO. OF CRIMPS PER END		
OSPREY	240	OSPREY	240	YOT37R37R	1	28.5	35.5	317.5	23.8	34.5	108.2	161.5	M	--	--	U-M	4	M	--	--	U-M	4	R/T OSPREY / TOOL-Y35 / DIE U-M
PELICAN	200	PELICAN	200	YOT361R361R	1	26.9	34.2	314.4	21.8	31.7	112.0	158.7	M	--	--	U-M	4	M	--	--	U-M	4	R/T PELICAN / TOOL-Y35 / DIE U-M
OSPREY	240	GOPHER	25	YOT37R2R	1	28.4	35.5	299.4	8.9	16.5	25.9	68.5	M	--	--	U-M	4	BG	--	--	U-BG	1	R-OSPREY / T-GOPHER - TOOL Y35 DIES R-U-M T-U-BG
PELICAN	200	GOPHER	25	YOT361R2R	1	26.9	34.2	321.3	8.9	16.5	25.9	68.0	M	--	--	U-M	4	BG	--	--	U-BG	1	R-PELICAN / T-GOPHER - TOOL Y35 DIES R-U-M T-U-BG
WASP/DOG	100	WASP/DOG	100	YTU28R28R	1	19.6	29.2	179.3	15.1	27.0	50.8	90.7	L	--	--	U-L	2	L	--	--	U-L	2	R/T WASP/DOG TOOL Y35 DIE U-L
ANT	50	GNAT	25	YTU25R2W	1	10.4	17.5	122.9	7.1	16.5	25.9	62.0	C	W-C	2	--	--	BG	W-BG	1	--	--	R-ANT / T-GNAT / TOOL MD 6-8 DIES R-W-C T-W-BG

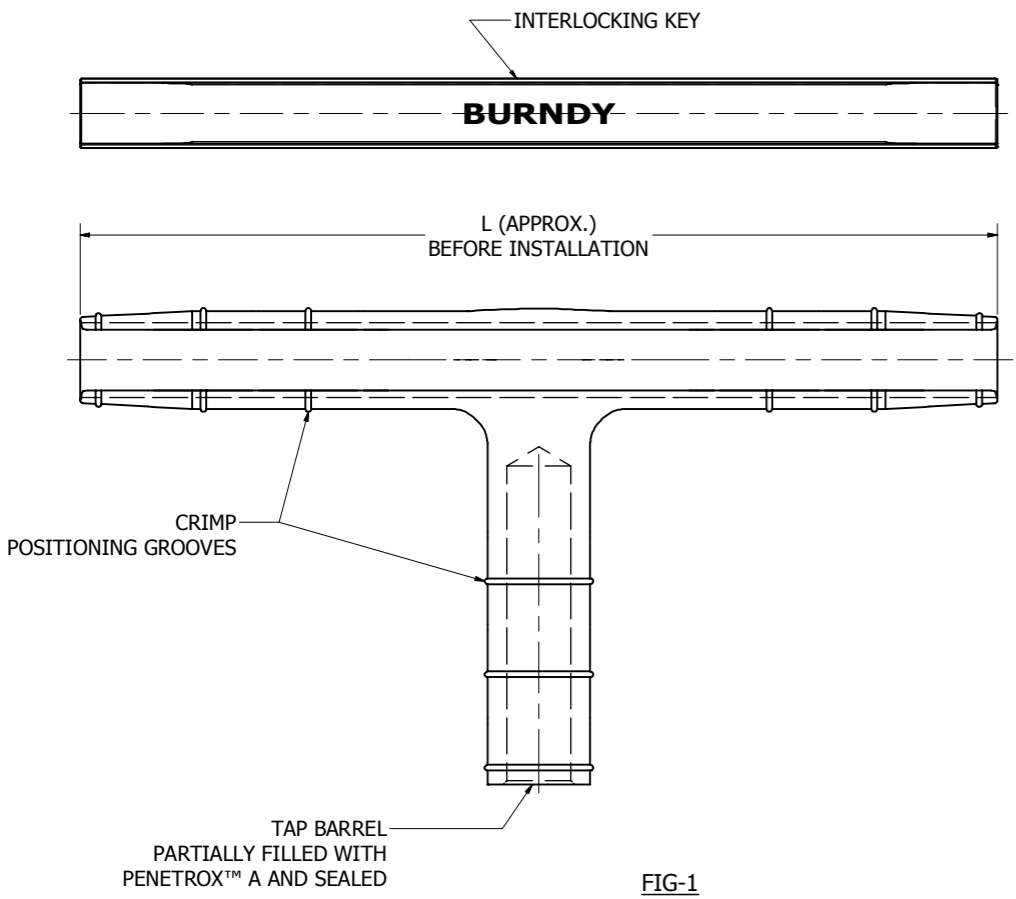

FIG-1

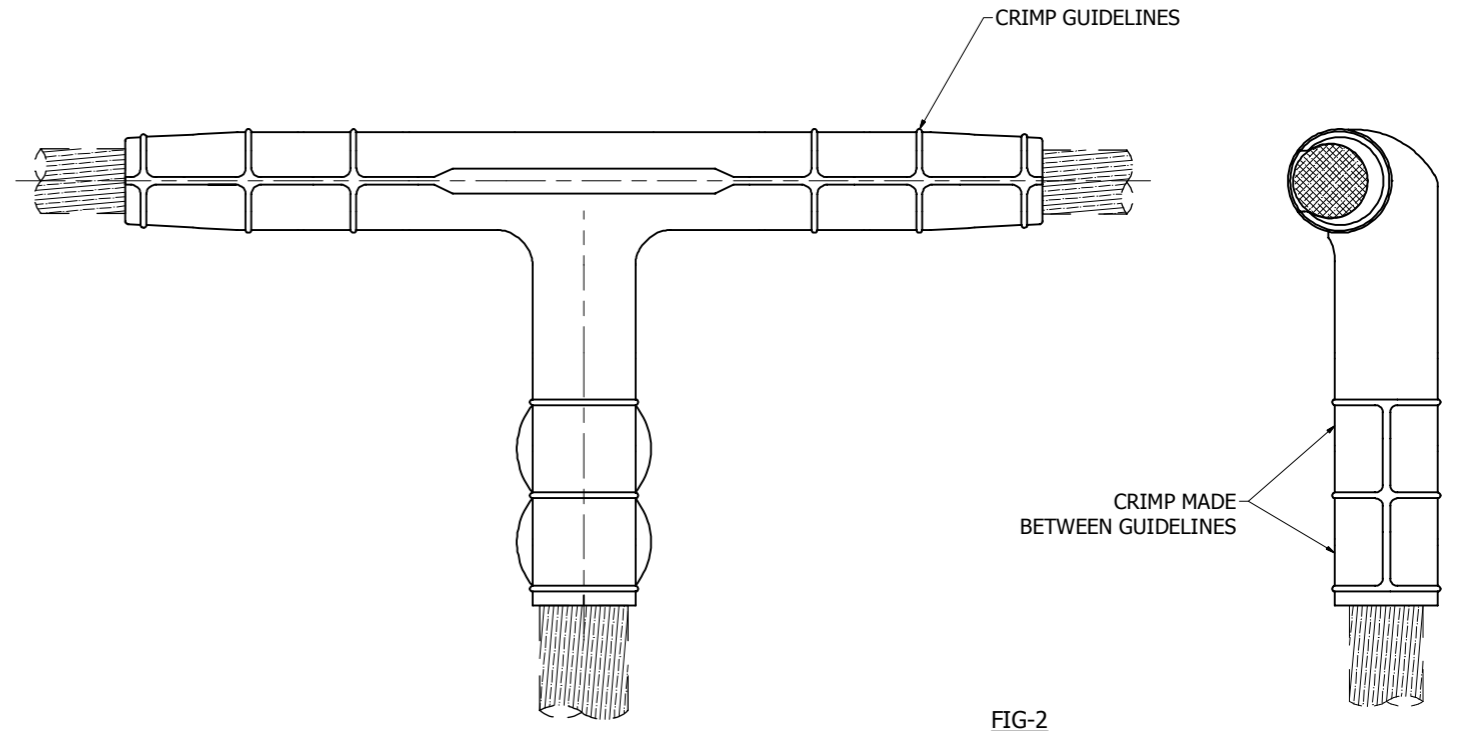
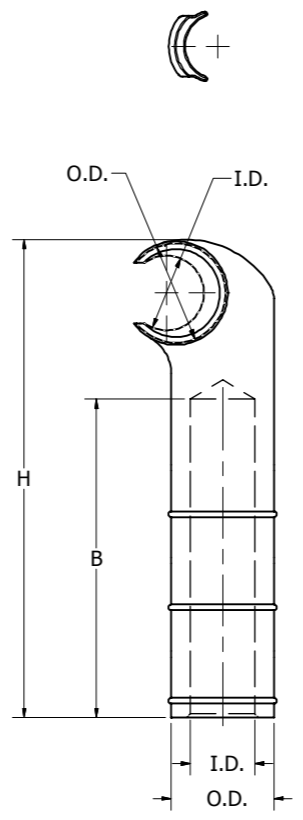

FIG-2  
VIEW AFTER INSTALLATION

NOTES:

1. SCRATCH BRUSH CONDUCTOR & CONNECTOR CONTACT SURFACES DRY THEN APPLY PENETROX™ 'A'. PENETROX™ 'A' NOT INCLUDED IN CAT. NO., BUT CAN BE PURCHASED FROM BURNDY CORP. IN CANS OR PLASTIC SQUEEZE BOTTLES.
2. INSERT CONDUCTOR IN CONNECTOR AND MAKE REQUIRED NO. OF CRIMPS STARTING @ CROTCH AND WORKING TOWARDS ENDS.
3. TWO CRIMPS MADE SIMULTANEOUSLY.
4. ALL DIMENSIONS ARE IN MILLIMETERS.
5. MATERIAL - CAST ALUMINUM ALLOY.

FOR PAKISTAN ONLY

TO ORDER BURNDY® PRODUCTS CALL  UNITED STATES 1-800-346-4175 (LONDONDERRY, NH)  CANADA: 1-800-361-6975 (QUEBEC) 1-800-387-6487 (ALL OTHER PROVINCES)  FOR PRODUCT INFO: <a href="http://www.burndy.com">http://www.burndy.com</a>	T - TAP	
	ITEM NO: N/A	
	CAT. NO: YTU--R--, YOT--R-- (TABLE)	
	DRAWN BY: J.R.C. 12/05/1888 CHECKER: K.L.H. 12/12/1988 DSN APRVL: V.P. 12/19/1988 MFG APRVL: -- QA APRVL: -- MKT APRVL: J HALL 07/16/2014	
	PROD FAM: -- PROJECT #: -- DOCUMENT TYPE: SALES REL LEVEL: Released	SIZE: D DRAWING NO: SD201453-01 REV: A SHEET 1 OF 1