

CATALOG NUMBER	CONDUCTOR					DIMENSIONS					INSTALLATION TOOLING					WIRE STRIP LENGTH	
	COPPER	STR	ALUMINUM	ACSR	STR	A DIA.	B	L	O.D.	P	DIE INDEX	COLOR CODE	MECHANICAL		HYDRAULIC		
													MD6,MD7	Y35,Y39, Y750,PAT750,Y45, Y46	Y48BH		Y60BHU
YE2CAG15	#2 (.292)	7	#2 SOL. (.258)	--	--	.25 [6]	.91 [23]	9.25 [235]	.65 [17]	6.00 [152]	BG 243 K5/8-1	RED	W-BG W243	U-BG U243 UK5/8-1T	--	--	1-1/16
YE2WAG5	--	--	#2 SOL. (.258)	--	--	.26 [7]	1.78 [45]	8.58 [218]	.65 [17]	6.00 [152]	BG 243 K5/8-1	ORANGE	W-BG W243	U-BG U243 UK5/8-1T	---	L243	1-7/8
YE1WAG1	--	--	#1 SOL. (.289) #2 SOL. (.292)	--	--	.26 [7]	1.78 [45]	8.58 [218]	.65 [17]	6.00 [152]	BG 243 K5/8-1	RED	W-BG W243	U-BG U243 UK5/8-1T	---	L243	1-7/8
YE2RG15	--	--	#1 (.328) #2 (.292) 7STR	#2 (.316) #2 (.325)	6-1 7-1	.32 [8]	1.70 [43]	9.38 [238]	.65 [17]	6.00 [152]	BG 243 K5/8-1	RED	W-BG W243	U-BG U243 UK5/8-1T	C243	L243	1-3/4
YE25RG7	--	--	1/0 (.368) 7 STR	1/0 (.398)	6-1	.32 [8]	2.50 [63]	10.12 [257]	.65 [17]	6.00 [152]	BG 243 K5/8-1	YELLOW	W-BG W243	U-BG U243 UK5/8-1T	C243	L243	2-1/2
YE28AG12	--	--	4/0 (.475) COMP 4/0 (.528) COMP	4/0 (.522) 6/1 COMP	--	.37 [9]	1.31 [33]	9.63 [244]	.65 [17]	6.00 [152]	K840 249 11A	PINK	W249 W-K840	U249 U-K840T	C249	L249	--
YE39AG8	--	--	700 Kcmil 61(.964) 750 Kcmil 61(.998)	--	--	.75 [19]	2.56 [65]	12.31 [313]	1.60 [41]	6.00 [152]	301	RED	--	P39ART	C39AR	L39RT	2-3/4
YE39AG7	--	--	--	--	--	.88 [22]	2.04 [52]	10.88 [276]	1.50 [38]	6.00 [152]	608 786	--	--	U608 U786	--	--	2-3/4

REV	DATE	DESCRIPTION	ECO	BY	C'H'K.
F	07/20/2018	YE28AG12 ADDED TO TABLE	49523	PP	VS

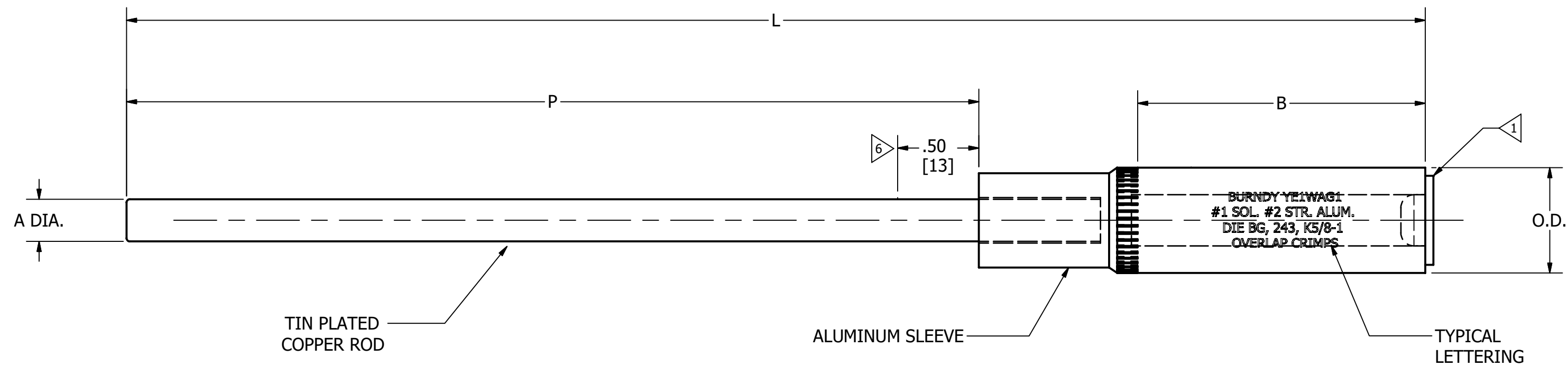

NOTES:

- 1 CONNECTOR SUPPLIED PREFILLED WITH PENETROX™ AND SEALED PENETROX™ IS COMPATIBLE WITH CABLE INSULATION.
- 2 "U" DIES CAN BE USED IN Y45 HYPRESS™ WITH ADAPTER PT6515.
- 3 "U" DIES CAN BE USED IN Y46 HYPRESS™ WITH ADAPTER PUADP-1
- 4 MULTIPLE CRIMP DIE SET (W-BG DIE) MAKES MORE THAN ONE CRIMP PER TOOL COMPRESSION.
5. REMOVED PER ECO 7335.
- 6 PLUG MAY BE BENT FOR INSTALLATION CONVENIENCE. IT IS RECOMMENDED THAT BENDING TAKE PLACE BEYOND THIS POINT.
7. DIMENSIONS IN BRACKETS [] ARE IN MILLIMETERS ROUNDED OFF TO THE NEAREST MILLIMETER, UNLESS OTHERWISE NOTED AND ARE FOR REFERENCE ONLY.
- 8 P39ART FOR USE WITH HYPRESS™ TOOL ONLY. PUADP-1 ADAPTER NOT REQUIRED.

TO ORDER BURNDY PRODUCTS CALL		HYPLUG™ CONNECTOR, ALUM.	
UNITED STATES 1-800-346-4175 (LONDONDERRY, NH)		ITEM NO: N/A	
CANADA: 1-800-361-6975 (QUEBEC) 1-800-387-6487 (ALL OTHER PROVINCES)		CAT. NO: YE-A- (TABLE)	
FOR PRODUCT INFO: http://www.burndy.com		DRAWN BY: J MITCHALD 09/01/1993	
		CHECKER: K HENRY 09/02/1993	
		DSN APRVL: C PALAGI 09/02/1993	
		MFG APRVL: --	
		QA APRVL: ALLOYD 09/06/1993	
		MKT APRVL: D HAMILTON 09/03/1993	
		PROJ FAMIL: --	
		DRAWING NO: SD208702-01	
		REV: F	
		SIZE: C	
		SHEET 1 OF 1	