

CATALOG NUMBER	COPPER CONDUCTOR		BOLT SIZE	METRIC BOLT SIZE	DIMENSIONS								COLOR CODE	INSTALLATION TOOLING (# CRIMPS)													
	SIZE	FIG.			B	C	E	K	L	N	T	O.D.		DIE INFORMATION		MECHANICAL				HYDRAULIC				DIELESS (# CRIMPS)	WIRE STRIP LENGTH		
					±.06	±.04	±.02	DIA. ±.02	±.09	±.03	REF.	±.01		DIE INDEX	TYPE	Y2MR	OUR840	MD6 MD7 MD6--R2	MD7-34R	BCT500 Y500CT	Y34A Y34B Y34BH	Y35, Y39 Y750, BAT35 BAT750, PAT750	Y46			Y45	
YGA8C-TC10	#8 SOLID #8 STRANDED	2	#10	M5	.81 [21]	.41 [10]	--	.21 [5]	1.57 [40]	.25 [6]	.08 [2]	.27 [7]	RED	49	RED DIE SET	RED (2)	X8CRT(2)	W8CVT(2) W8CRT(2)	W8CVT(2) W8CRT(2)	W8CVT(2) W8CRT(2) X8CRT(2)	-----	U8CRT(2)	U8CRT(2)	U8CRT(2)	RATCHET Y8MR8-1 (2)	7/8"	
YGA8C-TC14	#8 SOLID #8 STRANDED	2	1/4	M6	.81 [21]	.44 [10]	--	.27 [7]	1.69 [43]	.31 [8]	.08 [2]	.27 [7]	NEST		-----	-----	-----	-----	-----	-----	-----	-----	-----	-----	MECHANICAL: MY29-3 (2) MY29-11 (2)		
YGA8C-TC516	#8 SOLID #8 STRANDED	2	5/16	M8	.81 [21]	.51 [13]	--	.33 [8]	1.75 [44]	.34 [9]	.06 [2]	.27 [7]	INDENTOR		-----	-----	-----	-----	-----	-----	-----	-----	-----	-----	-----		
YGA6C-TC10	#6 SOLID #6 STRANDED	2	#10	M5	1.12 [28]	.42 [11]	--	.21 [5]	1.89 [48]	.25 [6]	.09 [2]	.29 [7]	BLUE	7 374	BLUE DIE SET	BLUE (2)	X5CRT(2)	W5CRT(2) W5CVT(2)	W5CRT(2) W5CVT(2)	W5CRT(2) W5CVT(2) X5CRT(2)	-----	U5CRT(2) U8CABT(2)	U5CRT(2) U8CABT(2)	U5CRT(2) U8CABT(2)	MECHANICAL: MY29-3 (2) MY29-11 (2)	1-3/16"	
YGA6C-TC14	#6 SOLID #6 STRANDED	2	1/4	M6	1.12 [28]	.45 [11]	--	.27 [7]	2.02 [51]	.31 [8]	.08 [2]	.29 [7]			NEST	-----	-----	-----	-----	-----	-----	-----	-----	-----	-----		HYDRAULIC: Y644M (1) BAT644M (1) PAT644M (1)
YGA6C-TC516	#6 SOLID #6 STRANDED	2	5/16	M8	1.12 [28]	.51 [13]	--	.33 [8]	2.08 [53]	.34 [9]	.07 [2]	.29 [7]			INDENTOR	-----	-----	-----	-----	-----	-----	Y34PR	Y34PR	Y34PR	Y34PR		-----
YGA6C-2TC38E2G1	#6 SOLID #6 STRANDED	1	3/8	M10	1.12 [28]	.58 [15]	.75 [19]	.40 [10]	3.42 [87]	.62 [16]	.06 [2]	.29 [7]	BROWN	10	BROWN DIE SET	BROWN (4)	X2CRT(2)	W2CRT(2) W2CVT(2)	W2CRT(2) W2CVT(2)	W2CRT(2) W2CVT(2) X2CRT(2)	-----	U2CRT(2)	U2CRT(2)	U2CRT(2)	-----	1-5/16"	
YGA6C-TC38	#6 SOLID #6 STRANDED	2	3/8	M10	1.12 [28]	.58 [15]	--	.40 [10]	2.21 [56]	.41 [10]	.06 [2]	.29 [7]			NEST	-----	-----	-----	-----	-----	-----	B6CD(1) A6CD(1)	U6CD-1(1)	U6CD-1(1)	U6CD-1(1)		-----
YGA6C-TC12	#6 SOLID #6 STRANDED	2	1/2	M12	1.12 [28]	.75 [19]	--	.52 [13]	2.46 [62]	.53 [13]	.12 [3]	.29 [7]			INDENTOR	-----	-----	-----	-----	-----	-----	Y34PR	Y34PR	Y34PR	Y34PR		-----
YGA2C-2TC38E2G1	#2 SOLID #2 STRANDED	1	3/8	M10	1.25 [32]	.60 [15]	.75 [19]	.40 [10]	3.66 [93]	.62 [16]	.12 [3]	.42 [11]	GRAY	8 346	GRAY DIE SET	GRAY (4)	X4CRT(2)	W4CRT(2) W4CVT(2)	W4CRT(2) W4CVT(2)	W4CRT(2) W4CVT(2)	-----	U4CRT(2) U6CABT(2)	U4CRT(2) U6CABT(2)	U4CRT(2) U6CABT(2)	MECHANICAL: MY29-3 (2) MY29-11 (2)	1-3/16"	
YGA2C-2TC38	#2 SOLID #2 STRANDED	1	3/8	M10	1.25 [32]	.60 [15]	1.00 [25]	.40 [10]	3.48 [88]	.41 [10]	.12 [3]	.42 [11]			NEST	-----	-----	-----	-----	-----	-----	B2CD(1) A2CD(1)	U2CD-1(1)	U2CD-1(1)	U2CD-1(1)		HYDRAULIC: Y644M (1) BAT644M (1) PAT81K- Y81K- SERIES (2)
YGA4C-TC34	#4 SOLID #4 STRANDED	2	3/4	M20	1.12 [28]	1.14 [26]	--	.81 [20]	3.20 [81]	.75 [19]	.15 [2]	.34 [9]	INDENTOR	-----	-----	-----	-----	-----	-----	-----	Y34PR	Y34PR	Y34PR	Y34PR	-----		

NOTES:

- MATERIAL: COPPER
- BARRELS ARE PREFILLED WITH PENETROX® "E2" AND INDIVIDUALLY SEALED.
- CATALOG # PT6515 ADAPTOR IS REQUIRED TO USE "U" DIES IN Y45 SERIES TOOLS.
- CATALOG # PUADP-1 ADAPTOR IS REQUIRED TO USE "U" DIES IN Y46 SERIES TOOLS.
- Y35P3 INDENTOR ADAPTOR REQUIRED FOR Y34PR INDENTOR.
- PERMANENT DIE IN TOOLING.
- DIMENSIONS IN BRACKETS [ ] ARE IN MILLIMETERS ROUNDED OFF TO THE NEAREST MILLIMETER, UNLESS OTHERWISE NOTED, AND ARE FOR REFERENCE ONLY.
- FOR USE BY CUSTOMERS THAT HAVE THIS HYPRESS™. NO NEW Y34A HYPRESS™ TOOLS ARE BEING PROCESSED. Y34A USES A--D NEST DIES ONLY.
- CONNECTORS ARE UL 467 LISTED.
- SUITABLE FOR DIRECT BURIAL IN EARTH OR CONCRETE.
- "X", "W-RT", "W-VT", & "U" DIE SETS ARE COLOR CODED. "A" & "B" DIES ARE NOT COLOR CODED. NESTS AND INDENTOR TYPE ARE NOT COLOR CODED.

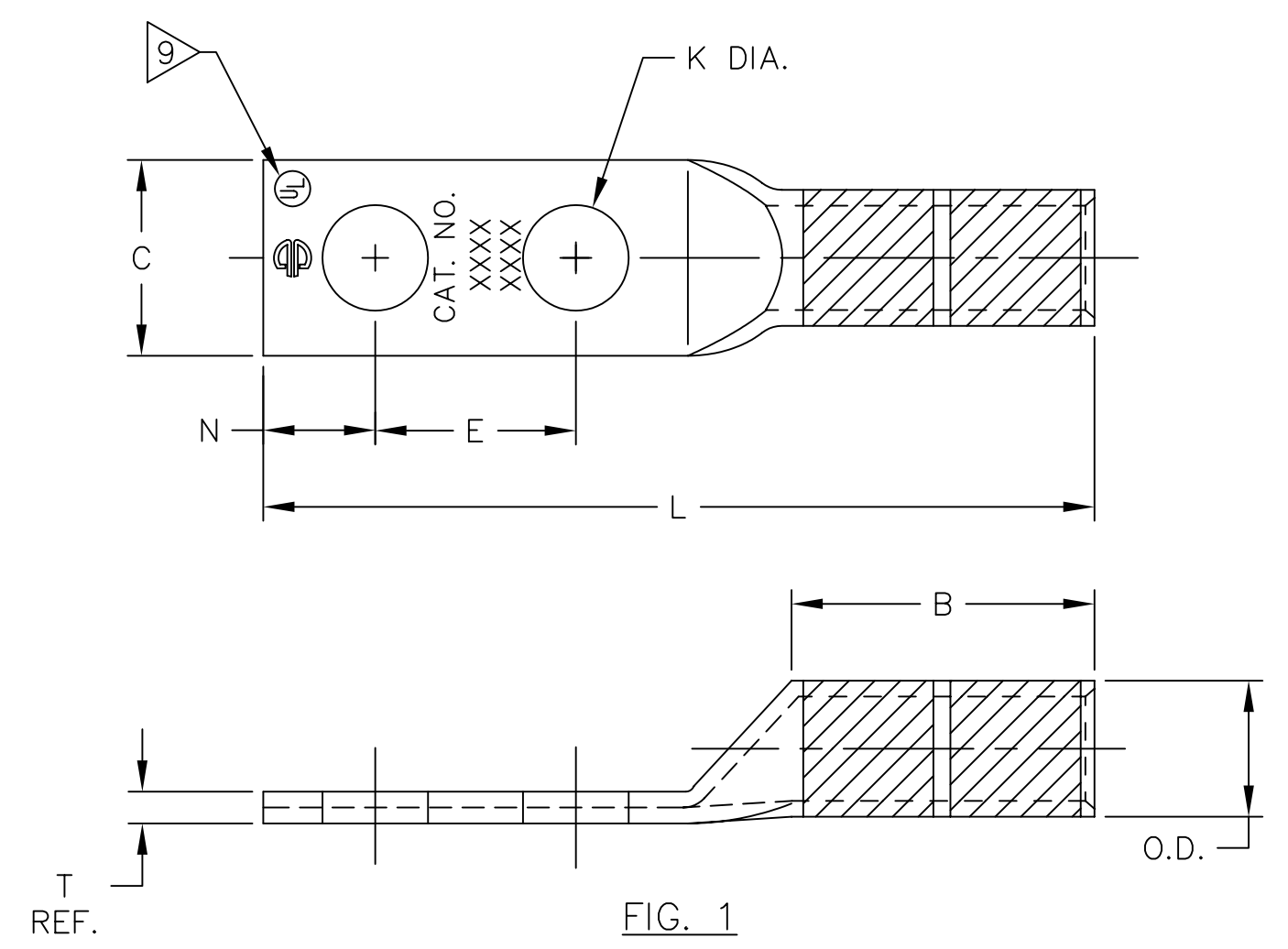

FIG. 1

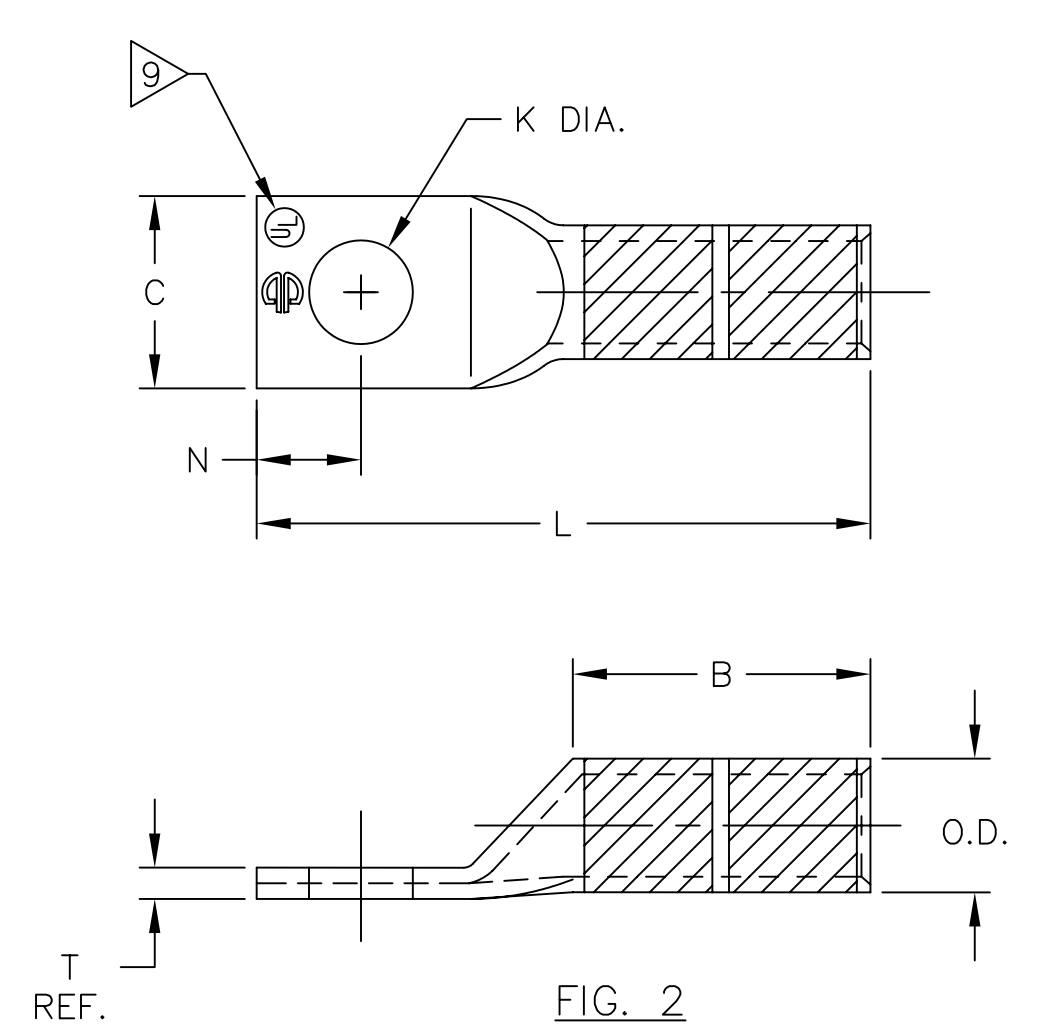

FIG. 2

TO ORDER BURNDY PRODUCTS CALL 1-800-346-4175  
MANCHESTER, NH 03109, USA  
FOR PRODUCT INFO = <http://www.fciconnect.com>

TO ORDER BURNDY® PRODUCTS CALL  
UNITED STATES:  
1-800-346-4175 (LONDONDERRY, NH)  
CANADA:  
1-800-361-6975 (QUEBEC)  
1-800-387-6487 (ALL OTHER PROVINCES)  
FOR PRODUCT INFO: <http://www.burndy.com>

HYLUG™ COPPER GROUND	
ITEM NO: N/A	
CAT NO: YGA-- (TABLE)	
SCALE: N/A	
DRAWN BY: R PERRAULT 1/13/95	
CHECKER: K HENRY 1/17/95	
DSN APPVL: C PALAGI 1/19/95	
MFG APPVL: --	
QC APPVL: D VARIO 1/25/95	
MKT APPVL: P WERTHMAN 1/25/95	
PROD FAM: --	
PROJECT #: --	SIZE
DOCUMENT TYPE: Sales	D
REL LEVEL: AutoCAD	
DRAWING NO	REV
SD209500-01	C
SHEET 1 OF 1	

REV.	DATE	DESCRIPTION	ECO	BY	C'K'D.
C	08/17/2018	ADDED CAT. # YA472NNT TO TABLE	49697	RB	VS