

REV	DATE	DESCRIPTION	ECO	BY	C'H'K.
B	06/11/2013	SALES DRAWING REDRAW IN INVENTOR	31880	PM	MB

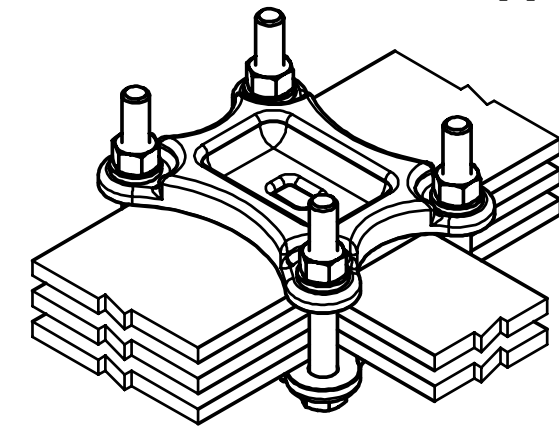
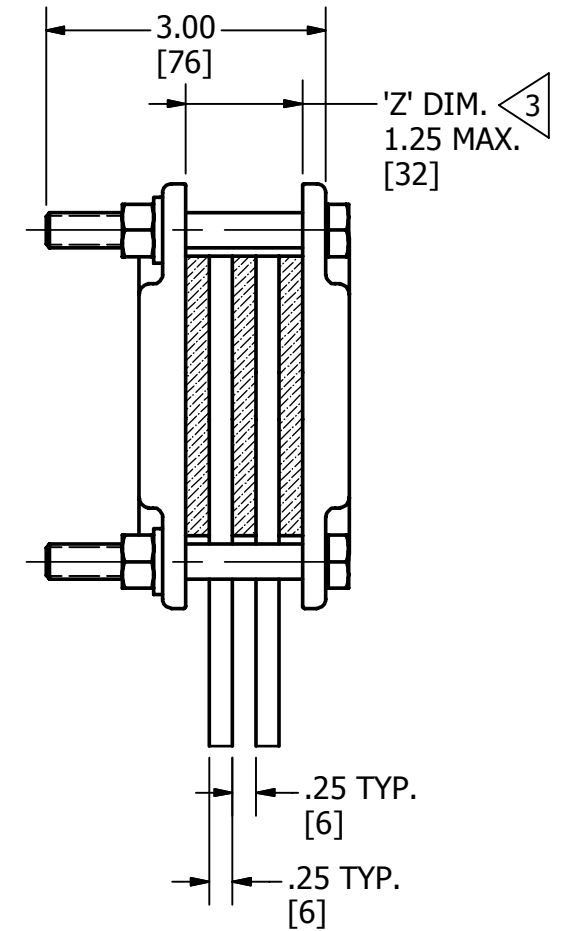
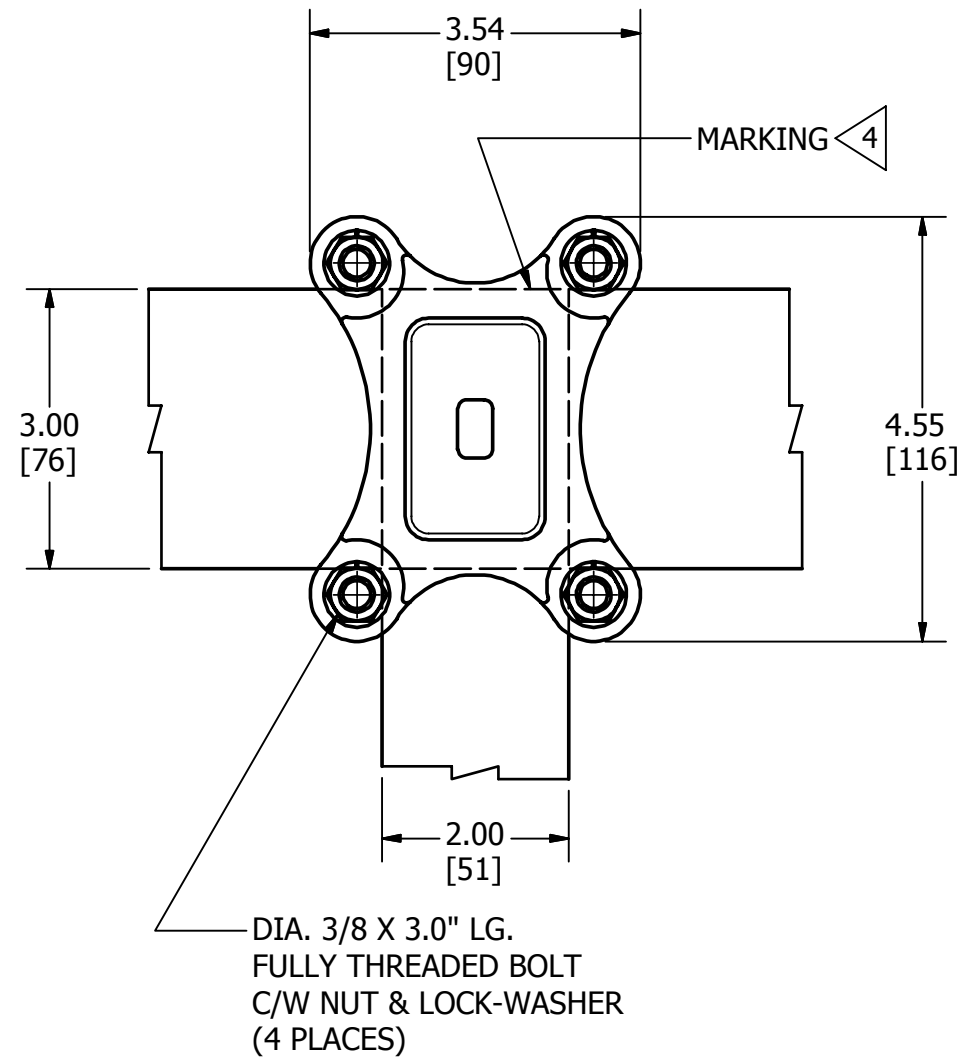

**NOTES:**

- DIMENSIONS IN BRACKETS [ ] ARE IN MILLIMETERS ROUNDED OFF TO THE NEAREST MILLIMETER, UNLESS OTHERWISE SPECIFIED AND ARE FOR REFERENCE ONLY.
- DO NOT SCALE DRAWING.
- $\triangleleft$  IF A GREATER THAN MAX. 'Z' DIM. IS REQUIRED, PLEASE CONTACT BURNDY.
- $\triangleleft$  MARKING:  
BURNDY  
HFBW32T5CG1-P1  
3 X 2 BAR
- MATERIAL: CAST COPPER ALLOY.
- FINISH:  
CLAMP - BRIGHT DIPPED.  
HARDWARE - YELLOW GALVANIZED.
- NOMINAL BOLT INSTALLATION TORQUE: 20 Nm (170 in.lbs) FOR 3/8" DIA. YELLOW GALVANIZED STEEL HARDWARE.
- ACCOMMODATES:  
RUN - 3.0" WIDE COPPER BAR.  
TAP - 2.0" WIDE COPPER BAR.

TO ORDER BURNDY® PRODUCTS CALL		BAR CLAMP ASSEMBLY	
UNITED STATES 1-800-346-4175 (LONDONDERRY, NH)		ITEM NO: 26002647	
CANADA: 1-800-361-6975 (QUEBEC) 1-800-387-6487 (ALL OTHER PROVINCES)		CAT. NO: HFBW32T5CG1	
FOR PRODUCT INFO: <a href="http://www.burndy.com">http://www.burndy.com</a>		DRAWN BY: PW 01/10/2001	
		CHECKER: V TORRES 01/22/2001	
		DSN APRVL: V TORRES 01/22/2001	
		MFG APRVL: --	
		QA APRVL: --	
		MKT APRVL: --	
		PROD FAM: --	
		PROJECT #: --	
		DOCUMENT TYPE: SALES	
		REL LEVEL: Released	
		SIZE: B	
		DRAWING NO: SD214229-01	REV: B
		SHEET 1 OF 1	