

CATALOG NO.	CONDUCTOR	FIG. NO.	B	C	D	E	K	L	N	O.D.	T	DIE NO.	HYPRESS™ & DIE SET WITH NO. OF CRIMPS								
													Y35	Y45L	Y48B	Y60	Y46				
													INSTALLATION DATA								
YCAK29A2G1	4/0 ACSR (.563) 250 kcmil (.575) ALUM. OR CU.	2	1.56	1.25	3.00	1.75	.56	5.63	.62	1.25	.25	705 K1 1/8 317	U705 U-K1-181T U317	U705 U-K1-181T U317	1	---	-	---	-		
YCAK28AG2	4/0 STR. (.528) AL OR CU	1	1.56	1.25	1.31	--	.56	3.94	.62	1.25	.25										
YCAK28A2G1	4/0 STR. COMP. (.475)	2	1.56	1.25	3.00	1.75	.56	5.63	.62	1.25	.25										
YCAK31AG1	350 kcmil (.710) AL OR CU	1	1.94	1.25	1.31	--	.56	4.52	.62	1.25	.38										
YCAK31A2G1	350 kcmil COMP. (.616)	2	1.94	1.25	3.00	1.75	.56	6.22	.62	1.25	.38	786 K1 5/16 608	U786 U608	U786 U608	1	C317	3	1	L317	3	1
YCAK34A2G3	500 kcmil (.813) AL OR CU 500 kcmil COMP. (.736)	2	2.19	1.50	3.00	1.75	.56	6.55	.62	1.50	.38										
YCAK39A2G2	750 kcmil (.998) 795 kcmil (1.026) 750 kcmil COMP. (.908)	2	2.50	1.50	3.00	1.75	.56	6.96	.62	1.50	.50										
YCAK44A2G2	1000 kcmil (1.152) 1000 kcmil COMP. (1.060)	2	2.91	1.69	3.00	1.75	.56	7.55	.62	1.84	.62										
YCAK36A2G1	600 kcmil (.893) 600 kcmil COMP. (.813)	2	2.19	1.50	3.00	1.75	.56	6.55	.62	1.50	.39	786 K1 5/16 608	U786 U608	U786 U608	1	C608	--	-			
YCAK448A2G1	1200 kcmil (1.263)	2	3.38	2.26	3.00	1.75	.56	8.02	.62	2.26	.62	478	--	-	--	-	C478	L478			
YCAK39A2G3	750 kcmil (.998) 795 kcmil (1.026) 750 kcmil COMP. (.908)	2	2.50	1.50	3.00	1.75	.56	6.96	.62	1.61	.50	724	--	-	--	-	--	-	L724	P724	

REV.	DATE	DESCRIPTION	ECO	BY	C'K'D.
A	05/28/10	REDRAWN TO AUTOCAD PER M/U.	20990	RB	PL

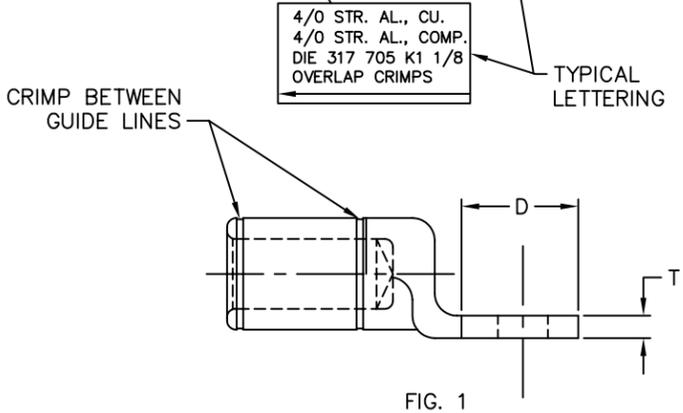
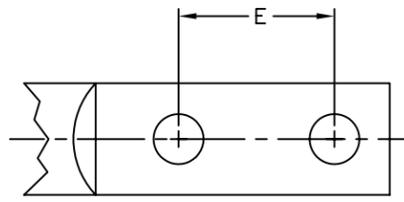
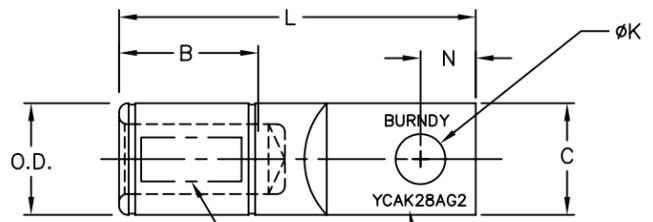

NOTES:

- 1 "U" DIES CAN BE USED WITH "Y45L" USING "U" DIE ADAPTER.
2. BARREL IS PARTIALLY FILLED WITH PENETROX™ THAT IS COMPATIBLE WITH CABLE INSULATION AND SEALED.
- 3 USE ONLY ON YCAK31 SIZES.
- 4 IF TIN PLATING IS DESIRED, ADD SUFFIX "TN" AT END OF CATALOG NUMBER, EXAMPLE: YCAK28AG2-TN.
5. MATERIAL: CAST ALUM. ALLOY.

REFERENCE: FD64096

TO ORDER BURNDY® PRODUCTS CALL UNITED STATES: 1-800-346-4175 (LONDONDERRY, NH) CANADA: 1-800-361-6975 (QUEBEC) 1-800-387-6487 (ALL OTHER PROVINCES) FOR PRODUCT INFO: http://www.burndy.com		HYLUG™ (ALUM.)	
		ITEM NO: ---	CAT NO: YCAK-A-6- (SEE TABLE)
SCALE: NTS		BURNDY	
DRAWN BY: R. BOISVERT 05/28/10			
CHECKER: P. LAPONIUS 05/28/10		DRAWING NO	
DSN APPVL: R. DEFRANCE 05/03/10		SD064095-01	
MFG APPVL: J. HEAD 05/05/10		REV	
QC APPVL: J. BRODEUR 05/06/10		A	
MKT APPVL: J. HALL 05/03/10		PROJECT #	
PROD FAM: ---		SIZE	
DOCUMENT TYPE: Sales		D	
REL LEVEL: AutoCAD		SHEET 1 OF 1	