

CAT. NO.	CONDUCTOR-RUN & TAP ACSR OR ALUM ALL STRANDING	B	BB	H	L	Q	O.D.	INSTALLATION DATA OVERLAP CRIMPS EACH END 6					
								TOOL INDEX NO.	BURNDY HYPRESS™ AND DIE SET	ALCOA DIE SET		T&B DIE SET	
										Y60	3>150A	3>H2H	T&B 21940 TYPE PRESS 4
YNT32R32R	300-336.4 kcmil ACSR 336.4-350 kcmil ALUM	3.90	4.18	6.39	15.46	5.80	1.19	717	L717	M717	H717	96	
YNT34R34R	397.5 kcmil ACSR 397.5-447 kcmil ALUM	3.93	4.22	6.53	15.60	5.88	1.30	719	L719	M719	H719	106	
YNT36R36R	477 kcmil ACSR 500-556.5 kcmil ALUM	4.19	4.48	6.85	16.29	6.15	1.41	720	L720	M720	H720	115	
YNT39R39R	556.5 kcmil ACSR 600-650 kcmil ALUM	4.47	4.76	7.13	16.69	6.38	1.50	722	L722	M722	H722	125	
YNT43R43R	605-666.6 kcmil ACSR 700-800 kcmil ALUM	4.53	4.87	7.20	17.48	6.40	1.61	724	L724	M724	H724	140	
YNT451R451R-T	715.5-874.5 kcmil ACSR 795-1000 kcmil ALUM	4.56	5.18	7.70	17.60	6.80	1.80	725	L725	M725	H725	150	
YNT49R49R-T	900-1113 kcmil ACSR 45-7 STR 1033.5-1272 kcmil ALUM	4.57	5.21	7.90	17.66	6.91	1.97	727	L727	M727	H727	161	
YNT52R52R-T	1113 54-19 STR-1351 kcmil ACSR 1351.5-1510 kcmil ALUM	6.00	7.98	11.10	21.61	9.98	2.25	728	L728	M728	H728	189	
YNT54R54R-T	1431 kcmil ACSR 1590-1600 kcmil ALUM	6.00	7.98	11.10	21.61	9.98	2.25	728	L728	M728	H728	189	
YNT56R56R-T	1510.5-1590 kcmil ACSR 1700-1800 kcmil ALUM 1650 kcmil ACAR 42/19 STR	6.94	7.67	11.08	23.65	9.83	2.50	729	L729	M729	H729	204	
YNT58R58R-T	1780 kcmil ACSR 2000 kcmil ALUM	6.91	7.61	11.02	23.53	9.77	2.50	735	L735	M735	H735	212, 214	
YNT59R59R-T	2156-2167 kcmil ACSR 2300 kcmil ALUM	6.82	7.45	10.86	23.21	9.61	2.50	735	L735	M735	H735	214	
YNT594R594RT	2267-2500 kcmil ACAR 2300 kcmil ACSR 2500 kcmil ALUM	7.60	7.91	11.45	24.30	10.15	2.60	740	L740	----	----	----	
YNY54R54R	1431 kcmil ACSR 1590-1600 kcmil ALUM	6.00	7.62	10.75	21.61	9.64	2.25	728	L728	M728	H728	189	

REV.	DATE	DESCRIPTION	ECO	BY	C'K'D.
14	12/14/00	REDRAWN TO CAD	6187	BM	PL

NOTES:

- 1 CONNECTOR TAP SUPPLIED PREFILLED WITH PENETROX™ AND SEALED.
- 2 OVERLAP CRIMPS.
- 3 THE DIES LISTED ARE MANUFACTURED BY FCI USA INC. FOR USE IN ALCOA H2H & 150A PRESSES.
- 4 THE EQUIVALENT T&B DIE INDEXES ARE LISTED FOR YOUR CONVIENCE.
- 5 PENETROX™ "A" NOT INCLUDED IN CATALOG NO. MAY BE PURCHASED FROM FCI USA INC.
- 6 FOR INSTALLATION INSTRUCTIONS SEE SD66667.
- 7 PRODUCT IDENTIFIER PER INTERNAL SPEC. L4116, TYPE 4A.

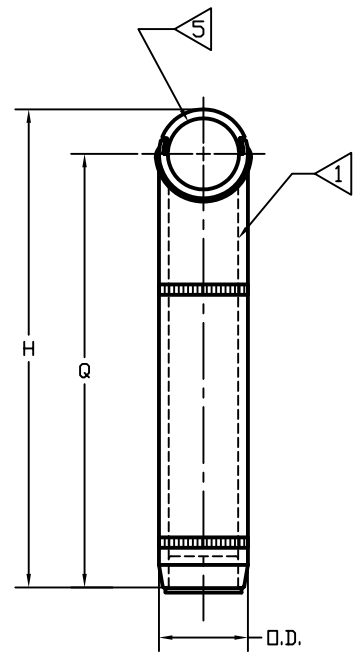
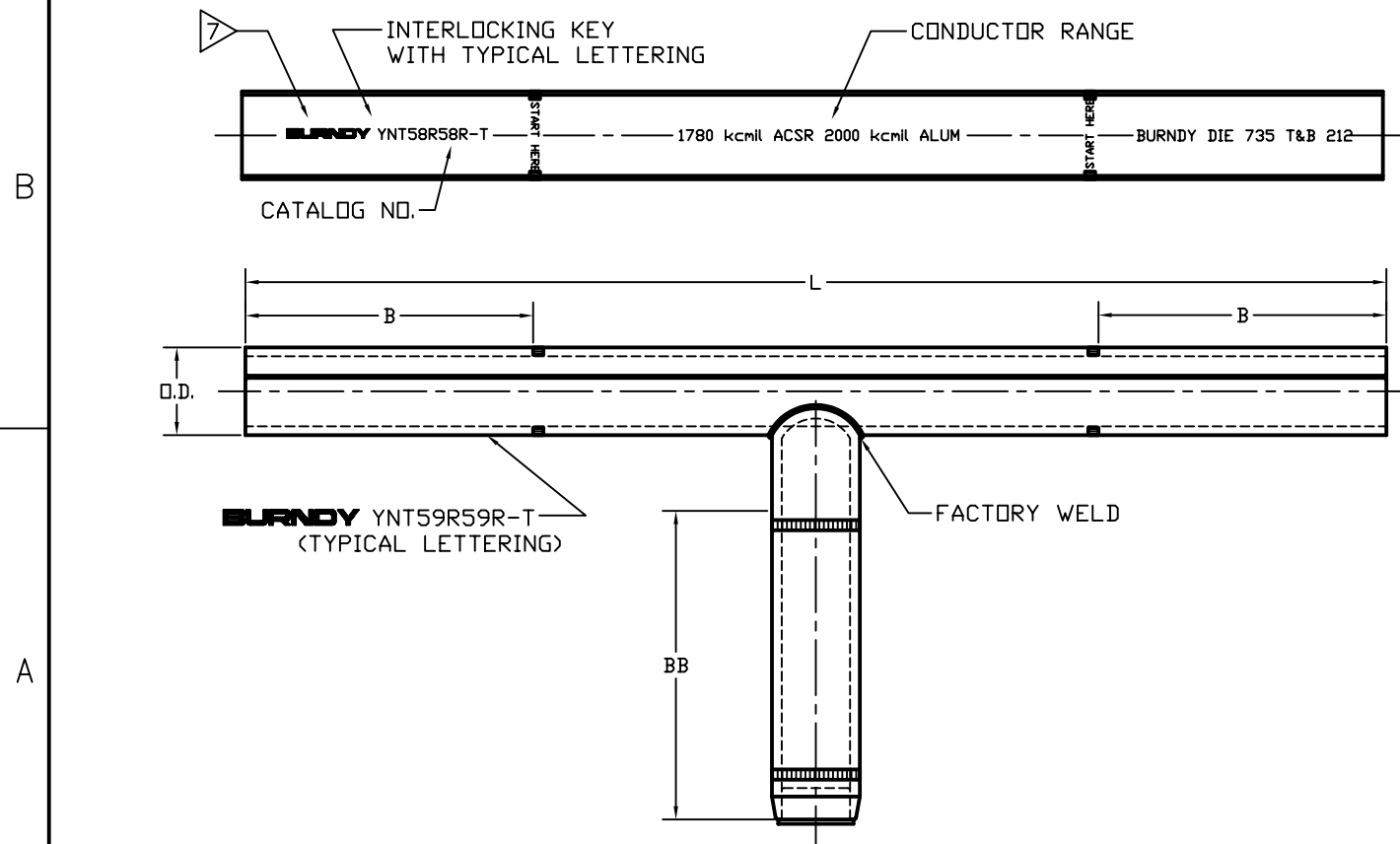

MATERIAL: ALUMINUM
REFERENCE: SD68063, SD66667

TO ORDER BURNDY® PRODUCTS CALL
UNITED STATES:
1-800-346-4175 (LONDONDERRY, NH)
CANADA:
1-800-361-6975 (QUEBEC)
1-800-387-6487 (ALL OTHER PROVINCES)
FOR PRODUCT INFO: <http://www.burndy.com>

COMPRESSION T-TAPS (EXTRUDED)	
ITEM NO: N/A	
CAT NO: YNT-R-R	
SCALE: N/A	
DRAWN BY: DTH	12/26/67
CHECKER: WAH	9/30/68
DSN APPVL: WR	10/3/68
MFG APPVL: --	--
QC APPVL: --	--
MKT APPVL: --	--
PROJ FAM: --	--
PROJECT #: --	SIZE
DOCUMENT TYPE: Sales	D
REL LEVEL: AutoCAD	
DRAWING NO	REV
SD065177-01	14
SHEET 1 OF 1	