

DRAWING NO.
SD68723

REV.	DATE	DESCRIPTION	ECO	BY	C'K'D.
A	10/25/01	REDRAWN TO CAB & DELETE CAT. # YNA43R-90 FROM TABLE PER M/U	6892	DB	PL

CATALOG NO.	CONDUCTOR ACSR OR ALUM. ALL STRANDING	FIG. NO.	O.D.	B	C	D	H	L APPROX.	N	T	DIE NO.	INSTALLATION DATA			T & B DIE NO.
												BURNDY HYPRESS™ & DIE SET WITH NO. OF CRIMPS			
												Y48B	Y486RB	Y60	
YNA49RTG17	900-1113 kcmil ACSR 45-7 STR 1033.5-1272 kcmil ALUM. 983.1-1198 kcmil ACAR	1	1.97	4.87	4.00	4.12	-	11.72	.62	.75	727			L727	161
YNA49RTG18		2				4.00	4.28	12.44							
YNA49RTG20		1				4.12	-	11.72							
YNA49RTG21		1				4.00	-	11.61							
YNA49RTG22		2				4.12	4.32	12.56							
YNA56RTG3		1				2.50	7.33	4.00							
YNA56RTG4	2	4.00	4.88	15.25											
YNA32R-4N	300-336.4 kcmil ACSR 356.4-350 kcmil ALUM. 395.1-395.2 kcmil ACAR	1	1.19	3.90	3.00	3.06	-	9.14	.38	.75	717			L717	96
YNA451RT15G1	715.5-874.5 kcmil ACSR 795-1000 kcmil ALUM. 840.2-927.2 kcmil ACAR	2	1.80	4.84	4.00	4.25	3.54	11.83	1.12	.38	725			L725	150
YNA451RT15G4		2				4.25	3.54	11.83							
YNA451RTG9		3				4.25	6.66	6.38							
YNA451RTG7		1				4.00	-	11.56							
YNA39RT-4N15	556.5 kcmil ACSR 600-650 kcmil ALUM. 634.9-653.1 kcmil ACAR	2	1.50	4.72	3.00	3.20	-	10.46	.62	.31	722			L722	125
YNA39RT-4N	1	-				10.00									
YNA39RT-4N90	3	6.86				5.06									
YNA58RTG3	1780 kcmil ACSR 2000 kcmil ALUM. 1933-2049 kcmil ACAR	1	2.50	7.27	4.00	4.00	-	14.00	1.12	.75	735			L735	214
YNA58RTG5		2				4.40	-	14.00							
YNA59RTG10	2156-2167 kcmil ACSR 2250-2300 kcmil ALUM. 2267-2338 kcmil ACAR	1	2.50	7.11	4.00	4.00	-	14.00	1.12	1.00	735			L735	214

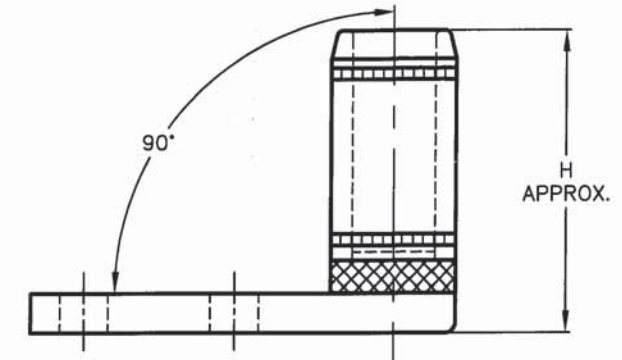

FIG. 3

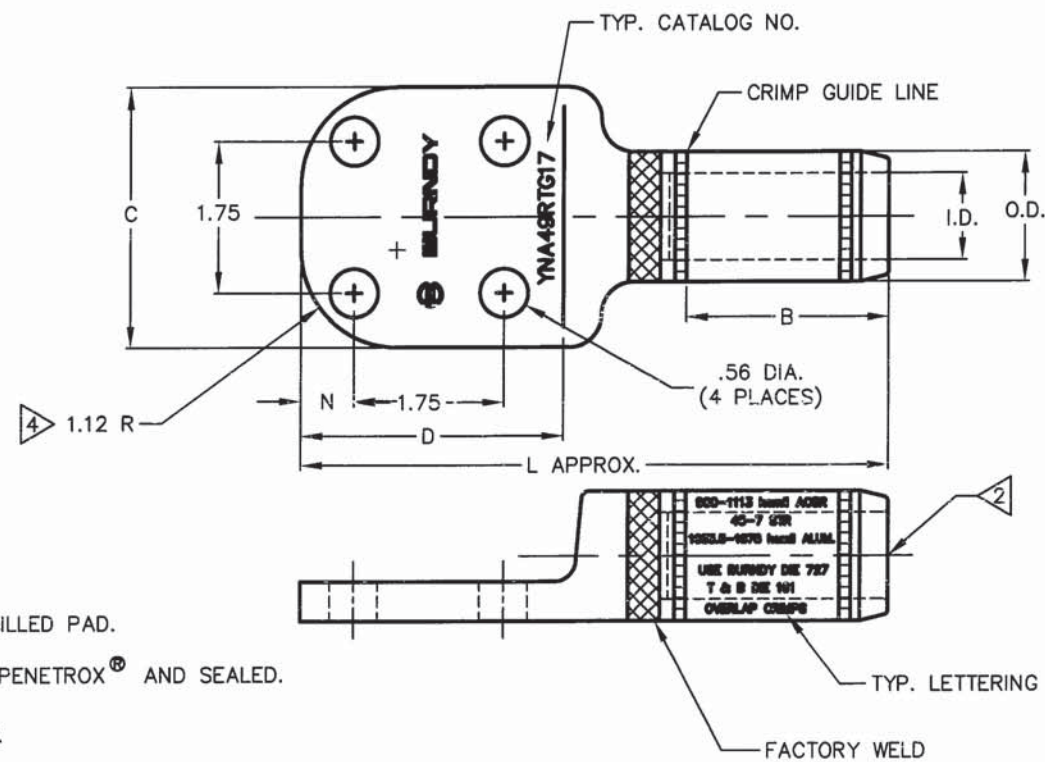

FIG. 1

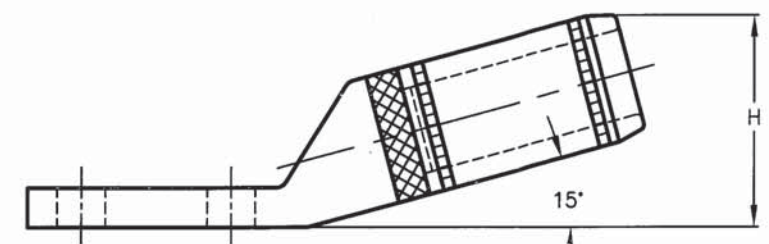

FIG. 2

NOTES:

- 1 THESE CAT. NO.'S TO HAVE UNDRILLED PAD.
- 2 BARRELS PARTIALLY FILLED WITH PENETROX® AND SEALED.
- 3 FINISHED TONGUE ON BOTH SIDES.
- 4 1.12R. APPLIES ONLY FOR CAT NO.'S: YNA451RT15G4
YNA451RTG7
YNA58RTG3
YNA58RTG5

REFERENCE: FD68724
PD68725
PD67506
FD69869
FD77272

SUPERSEDES: SD68723

TO ORDER BURNDY PRODUCTS CALL 1-800-346-4175
MANCHESTER, NH 03109, USA

HYLUG™

ITEM NO: N/A

CAT NO: YNA- (TABLE)

SCALE: NTS

DRAWN BY: PC 6/9/99

CHECKER: ---

DSN APPV: MB

MFG APPV: ---

QC APPV: ---

MKT APPV: ---

PROD FAM: ---

PROJECT #: ---

DOCUMENT TYPE: Sales

REL LEVEL: Released

BURNDY

DRAWING NO	REV
SD68723	A

SHEET 1 OF 1