

REV	DATE	DESCRIPTION	ECO	BY	C'H'K.
D	2018-04-16 00:00:00 EST	UPDATED AS PER MARKUP	48899	YR	VS

CATALOG NO.	CONDUCTOR		BOLT SIZE	FIG. NO.	DIMENSIONS								INSTALLATION TOOLING (# CRIMPS)										
	CODE (AWG)	NAVY			B ± .04	C ± .04	E ± .02	H REF.	K DIA. ± .02	L ± .06	N ± .03	O.D. ± .01	T REF.	Y MIN.	DIE INDEX	COLOR CODE	MECHANICAL RATCHET		HYDRAULIC		DIELESS (# CRIMPS)	WIRE STRIP LENGTH	
YAZV102TC10				1	.69 [18]	.36 [9]	.62 [16]	----	.21 [5]	2.04 [52]	.25 [6]	.21 [5]	.06 [2]	.90 [23]									
YAZV102TC1045			#10	2																		3/4	
YAZV102TC1090				3																			
YAZV102TC14				1																			
YAZV102TC1445			1/4 [M6]	2		.41 [10]	.62 [16]	----	.27 [7]	2.16 [55]	.31 [8]	.05 [1]	.96 [24]										
YAZV102TC1490				3																			
YAZV102TC14E2	14-10 AWG STR/SOL 2.5-6mm ² STR/SOL			1																			
YAZV102TC14E245			1/4 [M6]	2			.75 [19]	.77 [20]		2.16 [55]			1.09 [28]										
YAZV102TC14E290				3			.41 [10]	.94 [24]	.27 [7]	1.58 [40]	.31 [8]	.05 [1]											
YAZV102TC14E1					1			1.00 [25]	----	2.53 [64]			1.34 [34]										
YAZV102TC38				3/8	1		0.58 [15]	----	.41 [10]	2.72 [69]	.41 [10]	.09 [2]	1.43 [36]										
YAZV102N			1/4 [M6]	1	.69 [18]	.83 [21]	1.75 [44]	----	.56 [14]	4.34 [110]	.63 [16]	.10 [2]	2.40 [61]									3/4	
YAZV102N90				3			.94 [24]		3.18 [81]														

RATCHET:
Y8MRB-1
MR8G998
MR20
Y122CMR
(2) CRIMPS

NON-RATCHET:
Y10D
Y10-22
(2) CRIMPS

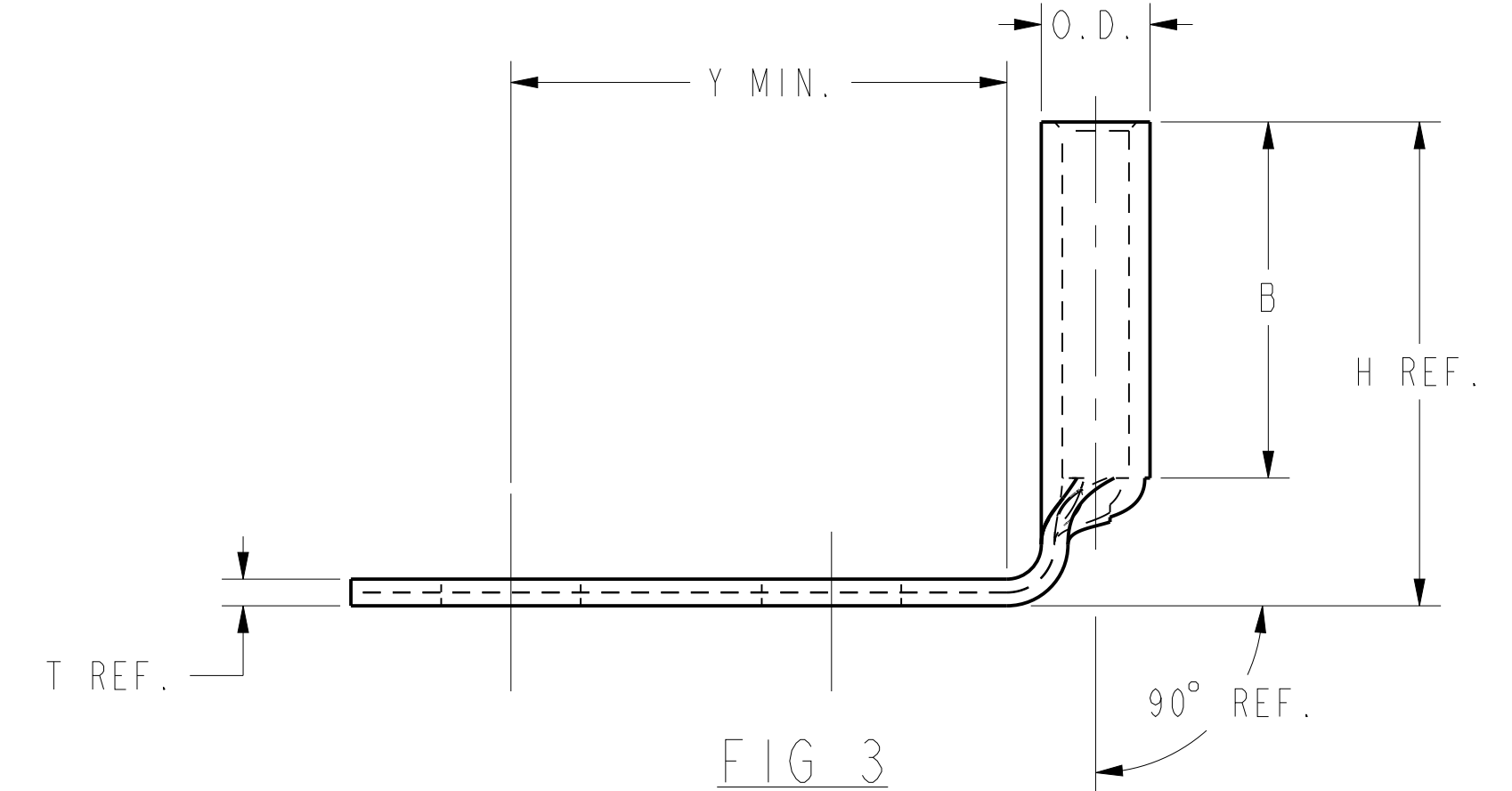
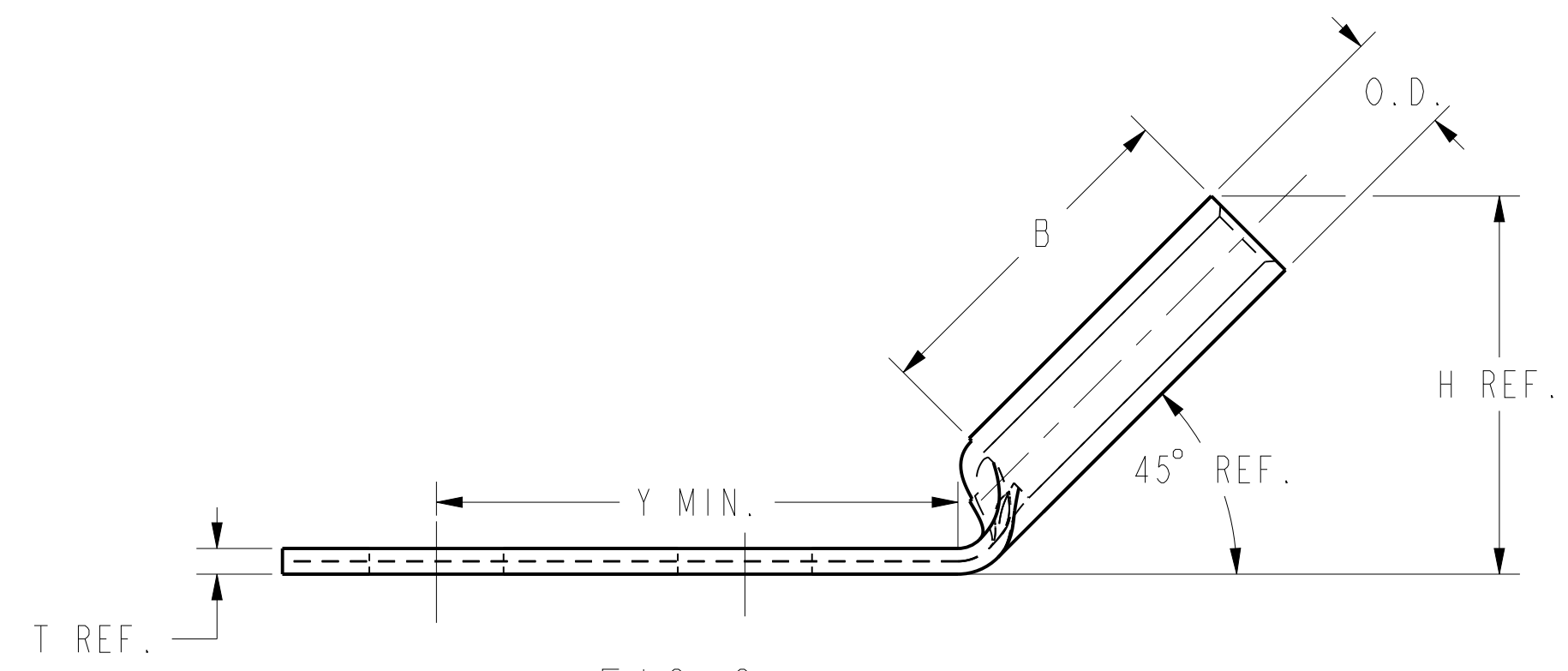
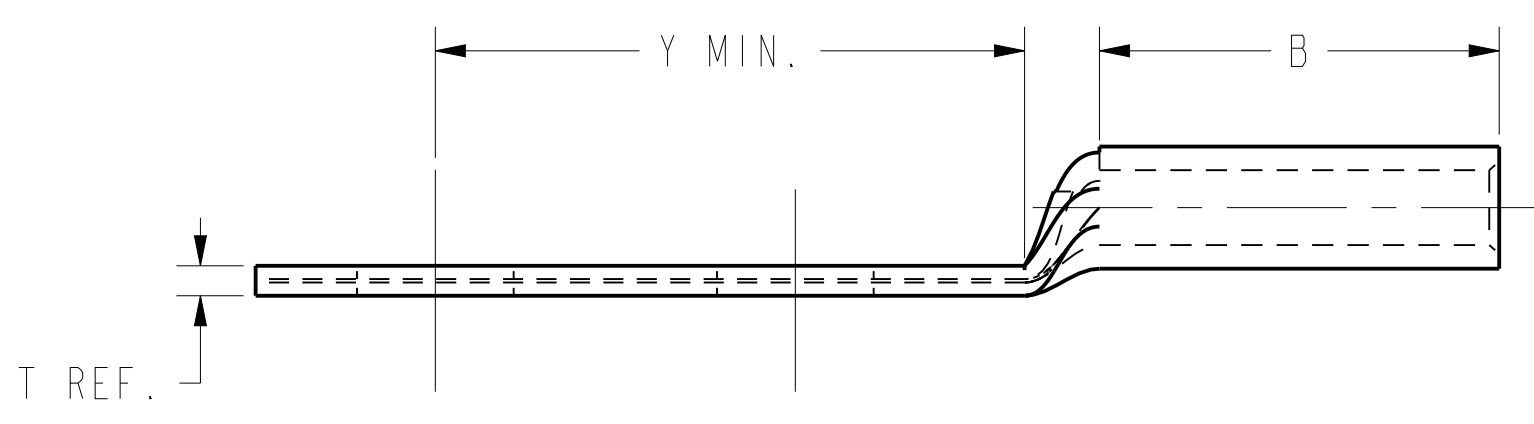
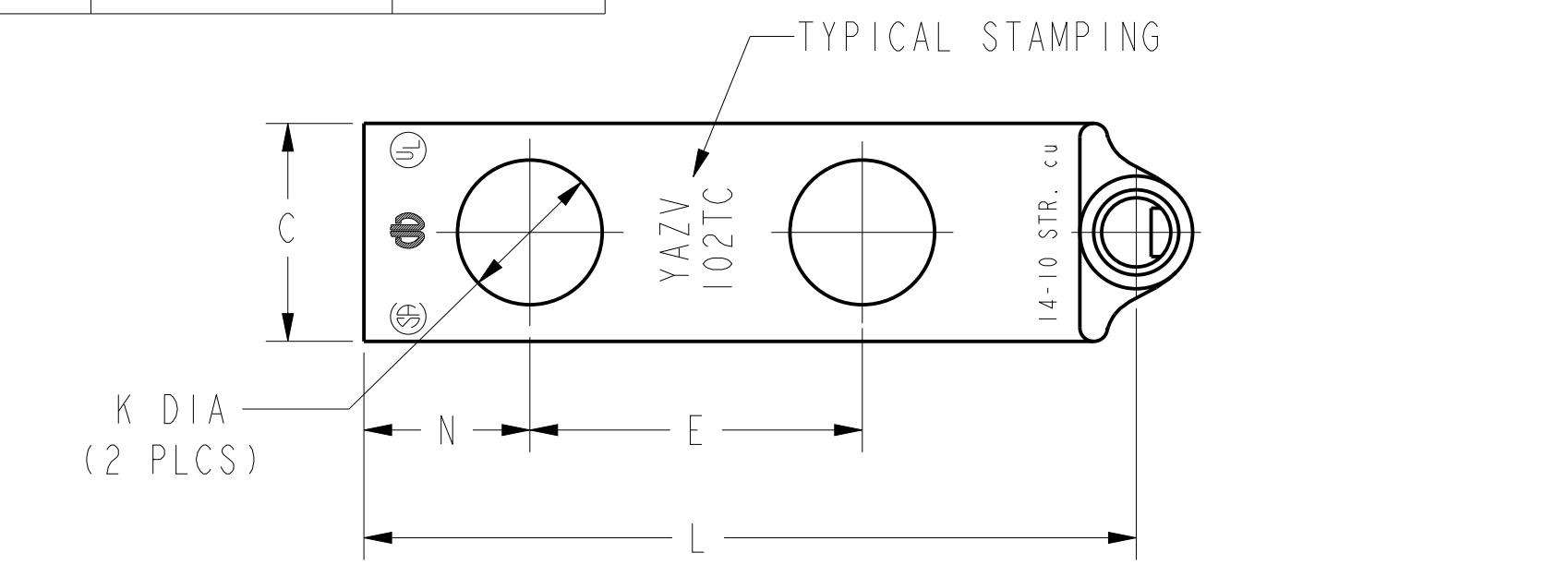
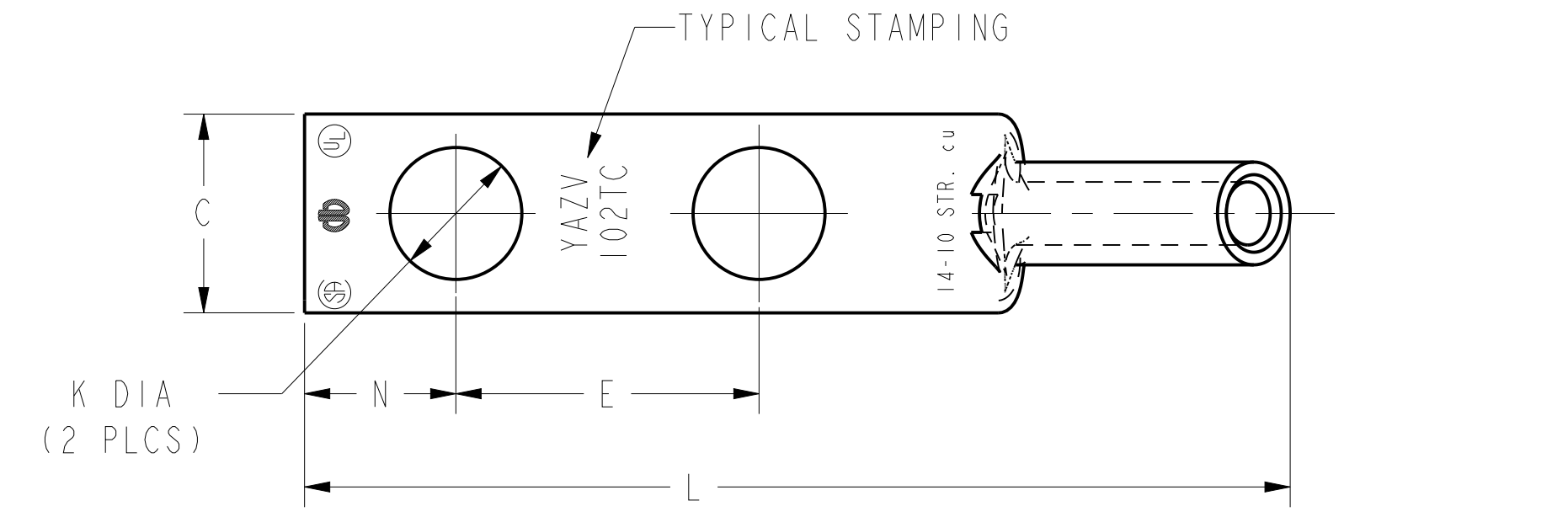
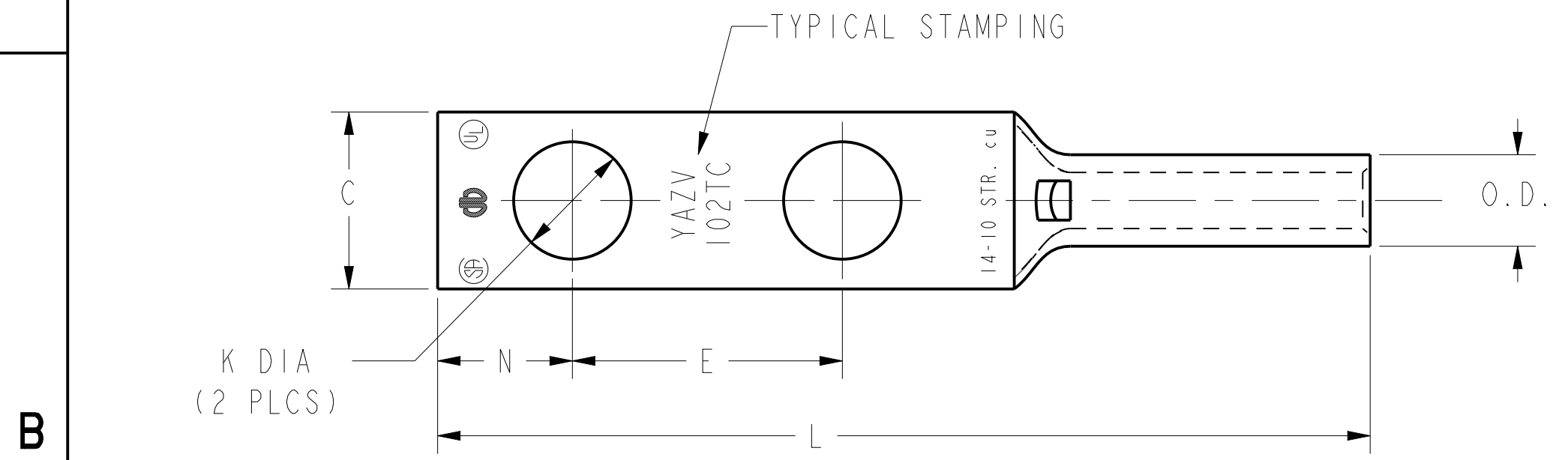

- NOTES:
- MATERIAL: COPPER TUBING.
 - FINISH: TIN PLATED
 - CATALOG # PT6515 ADAPTOR IS REQUIRED TO USE "U" DIES IN Y45 SERIES TOOLS.
 - CATALOG # PUADP-1 ADAPTOR IS REQUIRED TO USE "U" DIES IN Y46 SERIES TOOLS.
 - NAVY CABLE SIZE MAY BE OMITTED ON SOME SIZES BECAUSE OF SPACE LIMITATIONS.
 - PERMANENT DIE IN TOOLING.
 - DIMENSIONS, METRIC WIRE, & METRIC BOLT SIZES IN BRACKETS [] ARE IN MILLIMETERS. DIMENSIONS ARE ROUNDED OFF TO THE NEAREST MILLIMETER, UNLESS OTHERWISE NOTED, AND ARE FOR REFERENCE ONLY.

TO ORDER BURNDY® PRODUCTS CALL		HYLUG™ (TWO HOLE CODE)	
UNITED STATES 1-800-346-4175 (LONDONDERRY, NH)		ITEM NO: N/A	CAT. NO: YAZV10-2TC- (TABLE)
CANADA: 1-800-361-6975 (QUEBEC) 1-800-387-6487 (ALL OTHER PROVINCES)		DRAWN BY: D. BOISVERT 11/09/98	CHECKER: K. HENRY 12/03/98
FOR PRODUCT INFO: http://www.burndy.com		DSN APPVL: B. MACDONALD 12/02/98	MFG APPVL: N/A
		GA APPVL: S. GARY 11/30/98	MKT APPVL: N/A
		PROD FAM: --	DRAWING NO: SE211915
		PROJECT #: FPN1602130	SIZE: D
		DOCUMENT TYPE: Sales	SHEET 1 OF 36
		REL LEVEL: Released	REV: D

REV: PEO200