

REV	DATE	DESCRIPTION	ECO	BY	C'K'R.
C	2019-04-25 00:00:00 EDT	UPDATED AS PER MARKUP	51282	YR	RB

CATALOG NO.	CONDUCTOR		BOLT SIZE	FIG. NO.	DIMENSIONS										INSTALLATION TOOLING (# CRIMPS)																
	FLEX	CODE (AWG)			B	C	E	H MAX.	K DIA.	L	N	O.D.	T REF.	Y MIN.	DIE INDEX	COLOR CODE	MECHANICAL			HYDRAULIC			DIELESS (# CRIMPS)	WIRE STRIP LENGTH							
																	MD7-34R	OUR840	Y2MR $\triangle 5$	BCT500 Y500CT	Y750 Y35, BAT35 Y39, BAT750	Y46 $\triangle 4$			Y45 $\triangle 3$						
YAZV4C2TC38E2FX	#4 WELD 91/24 105/24	#4 AWG	3/8 [M10]	1	1.25	.58	.75	---	.40	3.14	.41	.38	.08	1.18	8 OR 346	GRAY	$\triangle 7$	$\triangle 7$	GRAY (4)	$\triangle 7$	$\triangle 7$	$\triangle 7$	MECHANICAL: MY29-11 (1) HYDRAULIC: Y644, Y644M Y644MBH, (1)	1-5/16							
YAZV4C2TC38E2FX45					2			[32]		[15]							[19]	[35]	[10]	[73]	[10]	[2]			[30]						
YAZV4C2TC38E2FX90					3													[42]		[47]											
YAZV4C2TC38FX	#4 WELD 91/24 105/24	#4 AWG	3/8 [M10]	1	3.39	.58	1.00	---	.40	3.39	.41	.38	.08	1.43	8 OR 346	GRAY	W4CVT X4CRT W4CRT (2)	X4CRT W4CVT (2)	GRAY (4)	W4CVT X4CRT W4CRT (2)	U4CRT (2)	U4CRT (2)	MECHANICAL: MY29-11 (1) HYDRAULIC: Y644, Y644M Y644MBH, (1)	1-5/16							
YAZV4C2TC38FX45					2			[86]		[80]							[10]	[2]	[36]												
YAZV4C2TC38FX90					3			[42]		[54]																					

C

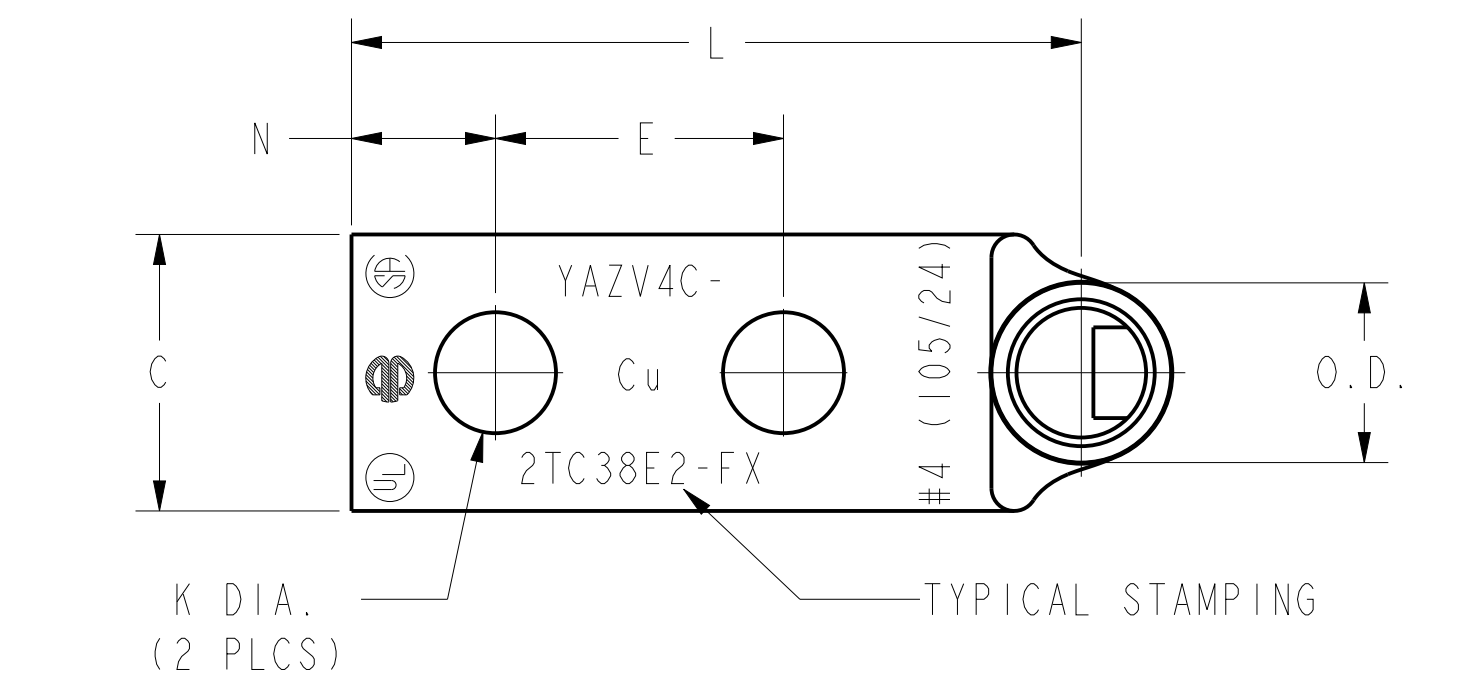
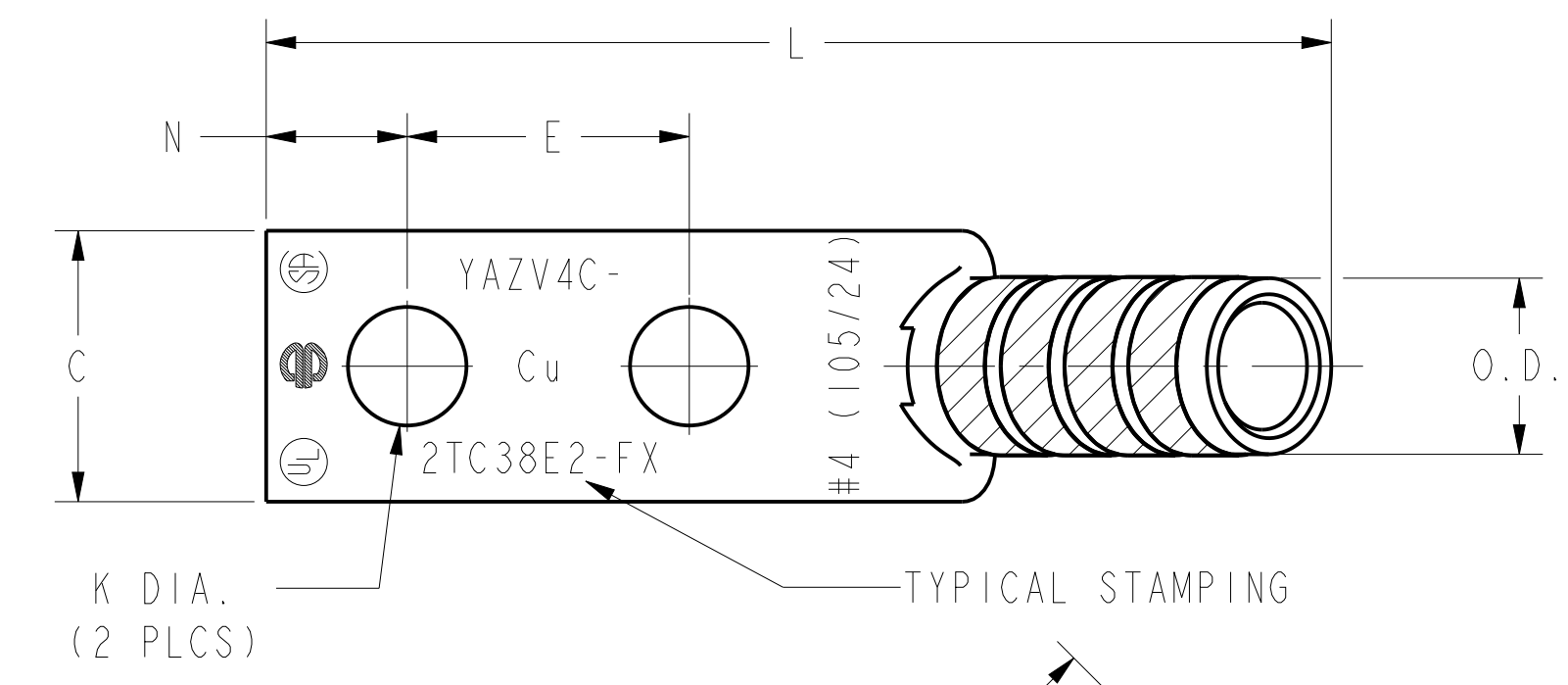
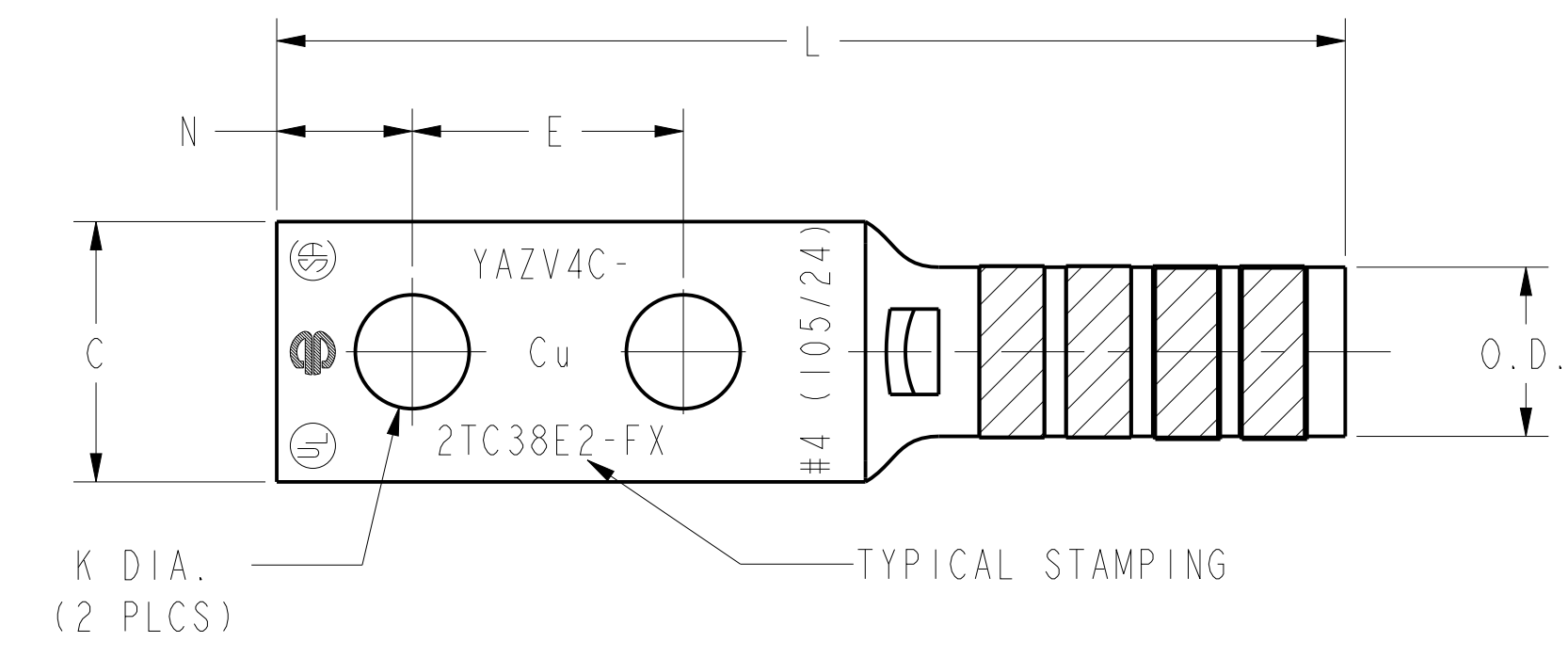

B

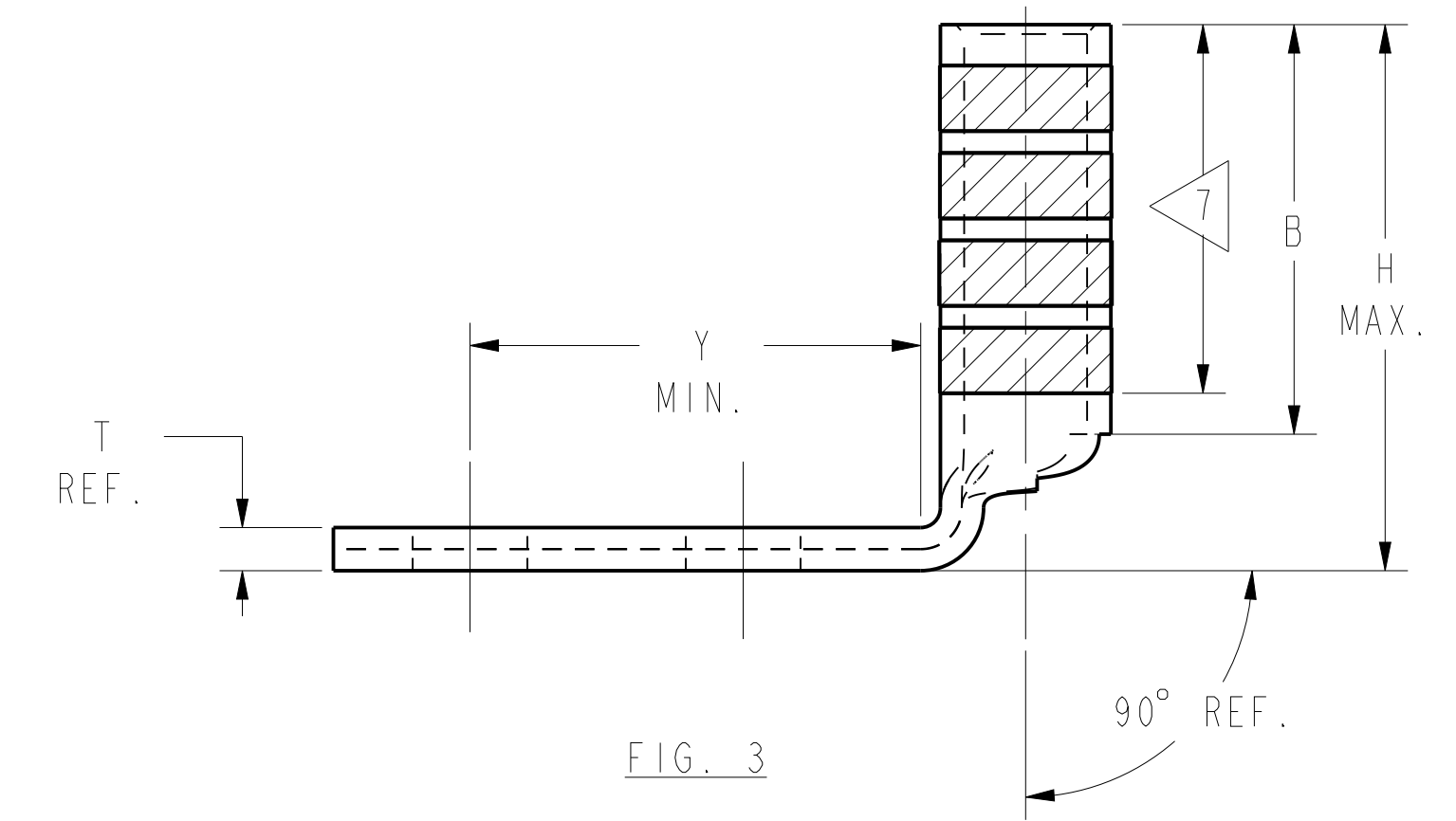
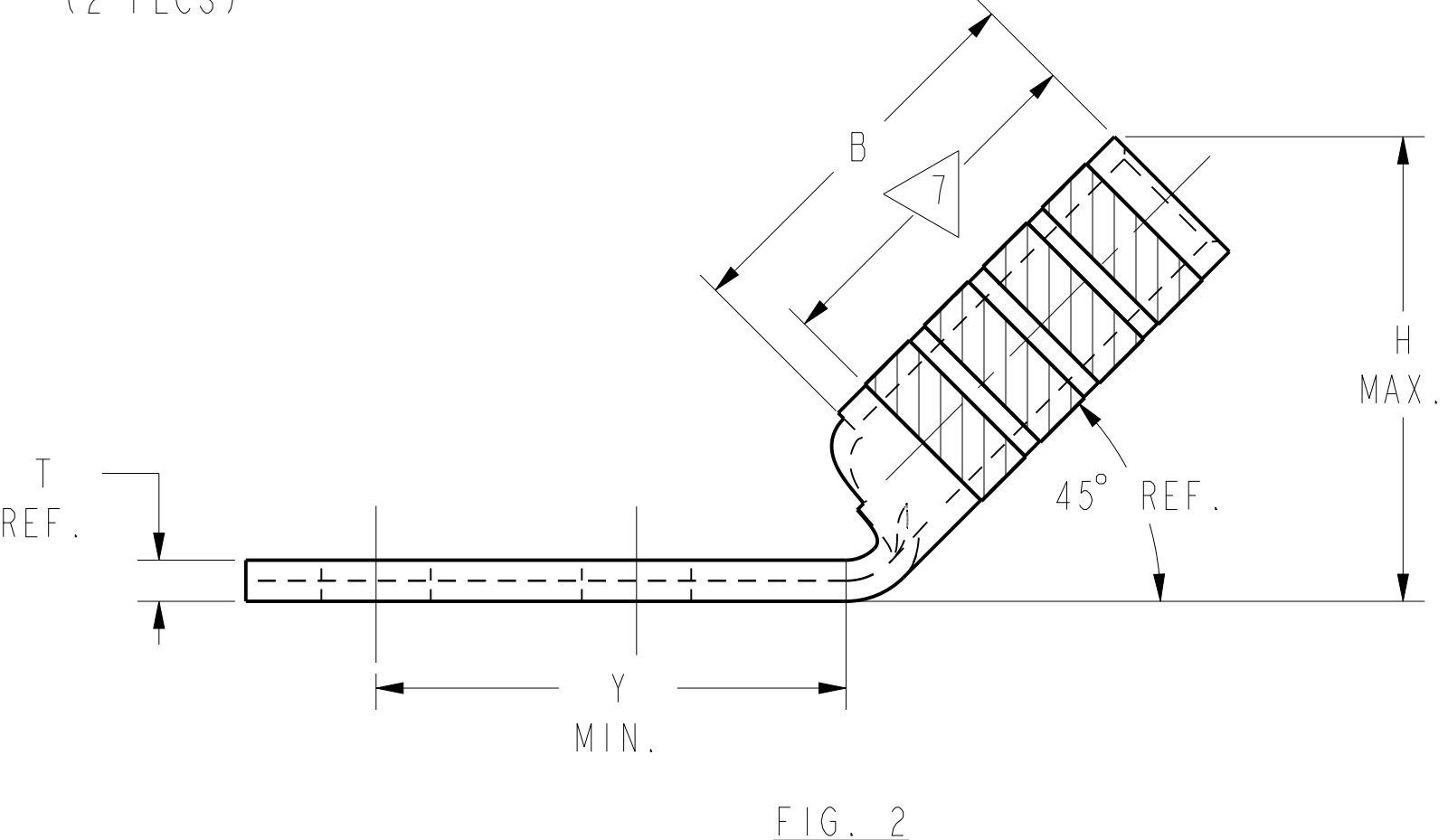
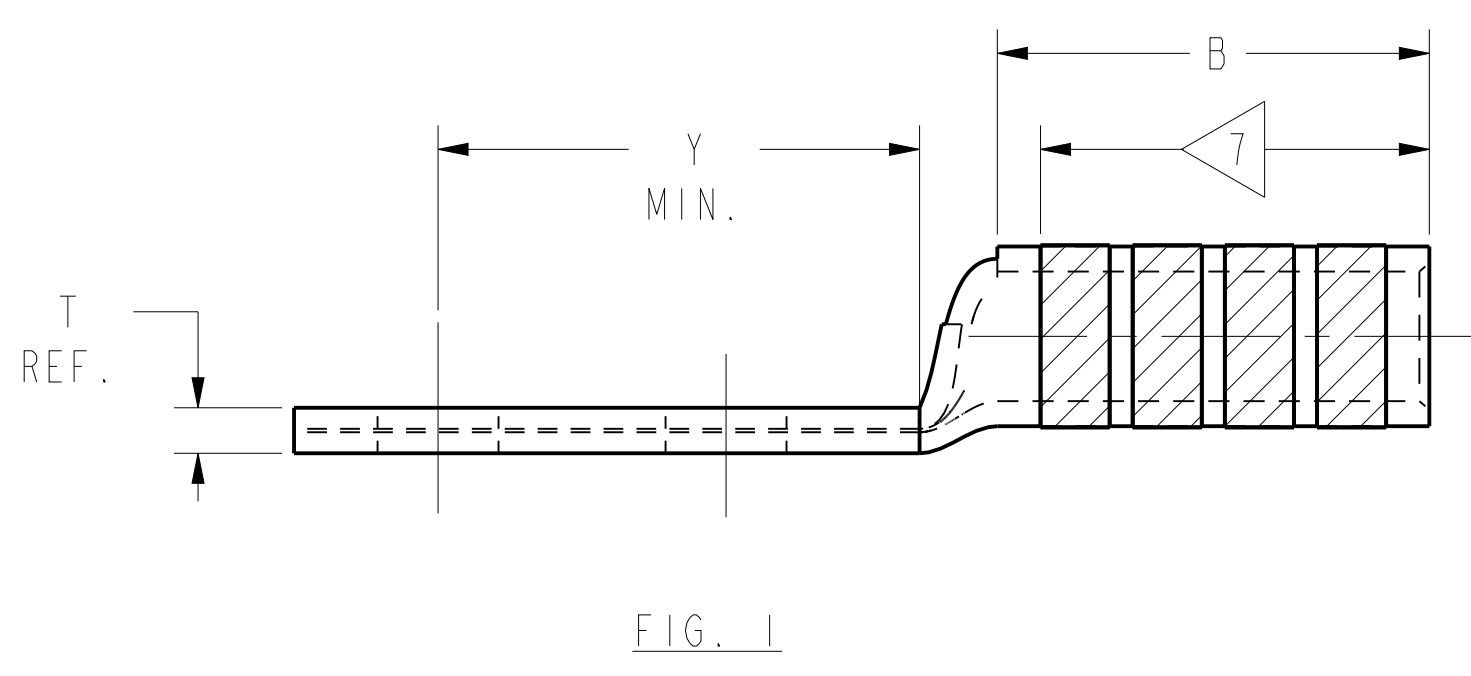

A

- NOTES:
- MATERIAL: COPPER TUBING.
 - FINISH: TIN PLATED.
FOR NICKEL PLATING ADD SUFFIX "NK" TO THE END OF THE CAT. NUMBER
 - CATALOG # PT6515 ADAPTOR IS REQUIRED TO USE "U" DIES IN Y45 SERIES TOOLS.
 - CATALOG # PUADP-1 ADAPTOR IS REQUIRED TO USE "U" DIES IN Y46 SERIES TOOLS.
 - PERMANENT DIE IN TOOLING.
 - DIMENSIONS IN BRACKETS [] ARE IN MILLIMETERS ROUNDED OFF TO THE NEAREST MILLIMETER, UNLESS OTHERWISE NOTED, AND ARE FOR REFERENCE ONLY.
 - CRIMP (# OF CRIMPS PER TABLE) WITHIN THE LENGTH BETWEEN THE INK STAMPED CRIMPING AREA.

TO ORDER BURNDY® PRODUCTS CALL		HYLUG™ (TWO HOLE FLEX)	
UNITED STATES 1-800-346-4175 (LONDONDERRY, NH)		ITEM NO: N/A	CAT. NO: YAZV4C- (TABLE)
CANADA: 1-800-361-6975 (QUEBEC) 1-800-387-6487 (ALL OTHER PROVINCES)		DRAWN BY: D BOISVERT 8/19/99	CHECKER: K HENRY 8/26/00
FOR PRODUCT INFO: http://www.burndy.com		DSN APPVL: RR TEAM 9/28/00	MFG APPVL: --
		GA APPVL: J BRODEUR 10/6/99	MKT APPVL: R ROBICHEAU 10/5/99
		PROD FAM: --	SCALE: NTS
		PROJECT #: --	SIZE: D
		DOCUMENT TYPE: Sales	DRAWING NO: SE212273
		REL LEVEL: Released	SHEET 10 OF 48

REV: PEC200