

REV	DATE	DESCRIPTION	ECO	BY	C.H.K.
D	11/29/2016 00:00:00 AM	YAZV282NTCFX "L" CHANGED	45429	SM	MB

CATALOG NO.	CONDUCTOR		BOLT SIZE	FIG. NO.	DIMENSIONS										INSTALLATION TOOLING (# CRIMPS)									
	FLEX	CODE (AWG)			B ±.08	C +.04 -.02	E ±.02	H REF.	K DIA. ±.02	L ±.09	N ±.03	O.D. ±.01	T REF.	Y MIN.	DIE INDEX	COLOR CODE	MECHANICAL		HYDRAULIC				DIELESS (# CRIMPS)	WIRE STRIP LENGTH
																	MD7-34R	OUR840	BCT500 Y500CT	Y750 Y35, BAT35 Y39, BAT750	Y46 \triangleleft 4	Y45 \triangleleft 3		
YAZV282TC38FX	4/0 WELD 550/24	4/0 AWG	3/8 [M10]	1	1.62 [41]	1.00 [25]	---	.40 [10]	3.96 [101]	.41 [10]	.77 [20]	---	15	PURPLE	\triangleleft 7	\triangleleft 7	\triangleleft 7	\triangleleft 7	\triangleleft 7	\triangleleft 7	MECHANICAL: MY29-11 (1)	1-11/16		
2				2.02 [51]			3.67 [93]		1.43 [36]															
3				2.36 [60]			2.30 [58]		---															
YAZV282TC38FX45	4/0 WELD 550/24	4/0 AWG	3/8 [M10]	1	1.14 [29]	1.75 [44]	---	.41 [10]	4.77 [121]	.15 [4]	2.18 [55]	---	15	PURPLE	\triangleleft 7	\triangleleft 7	\triangleleft 7	\triangleleft 7	\triangleleft 7	MECHANICAL: MY29-11 (1)	HYDRAULIC: Y644, Y644M Y644MBH, (1)	1-11/16		
2				2.02 [51]			4.48 [114]		2.36 [60]															
3				2.36 [60]			3.11 [79]		---															
YAZV282TC38E16FX	4/0 WELD 550/24	4/0 AWG	1/2 [M12]	1	1.62 [41]	1.75 [44]	---	.56 [14]	5.21 [132]	.62 [16]	.77 [20]	---	15	PURPLE	\triangleleft 7	\triangleleft 7	\triangleleft 7	\triangleleft 7	\triangleleft 7	MECHANICAL: MY29-11 (1)	HYDRAULIC: Y644, Y644M Y644MBH, (1)	1-11/16		
2				2.02 [51]			4.64 [118]		---															
3				2.36 [60]			3.27 [83]		---															

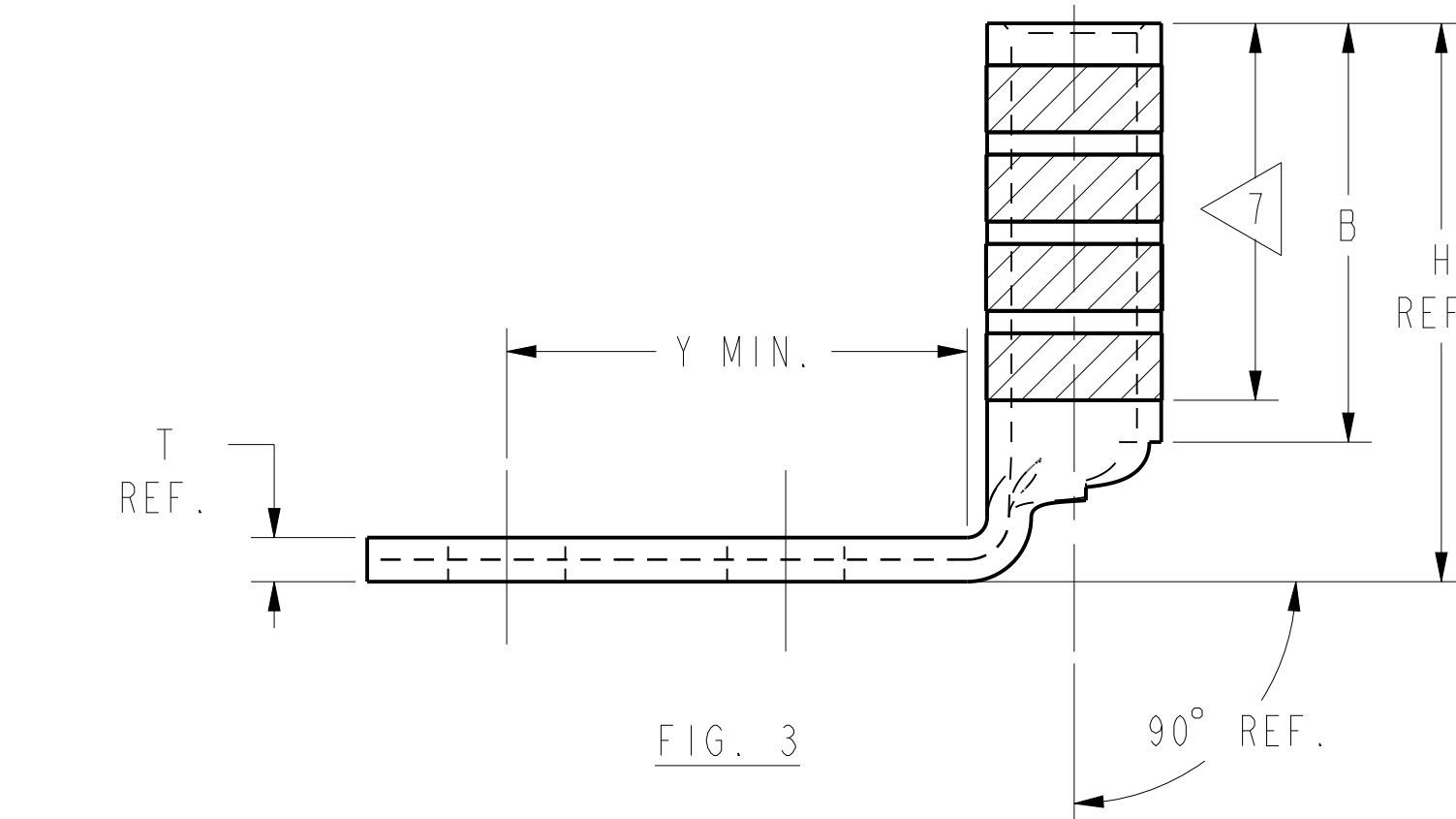
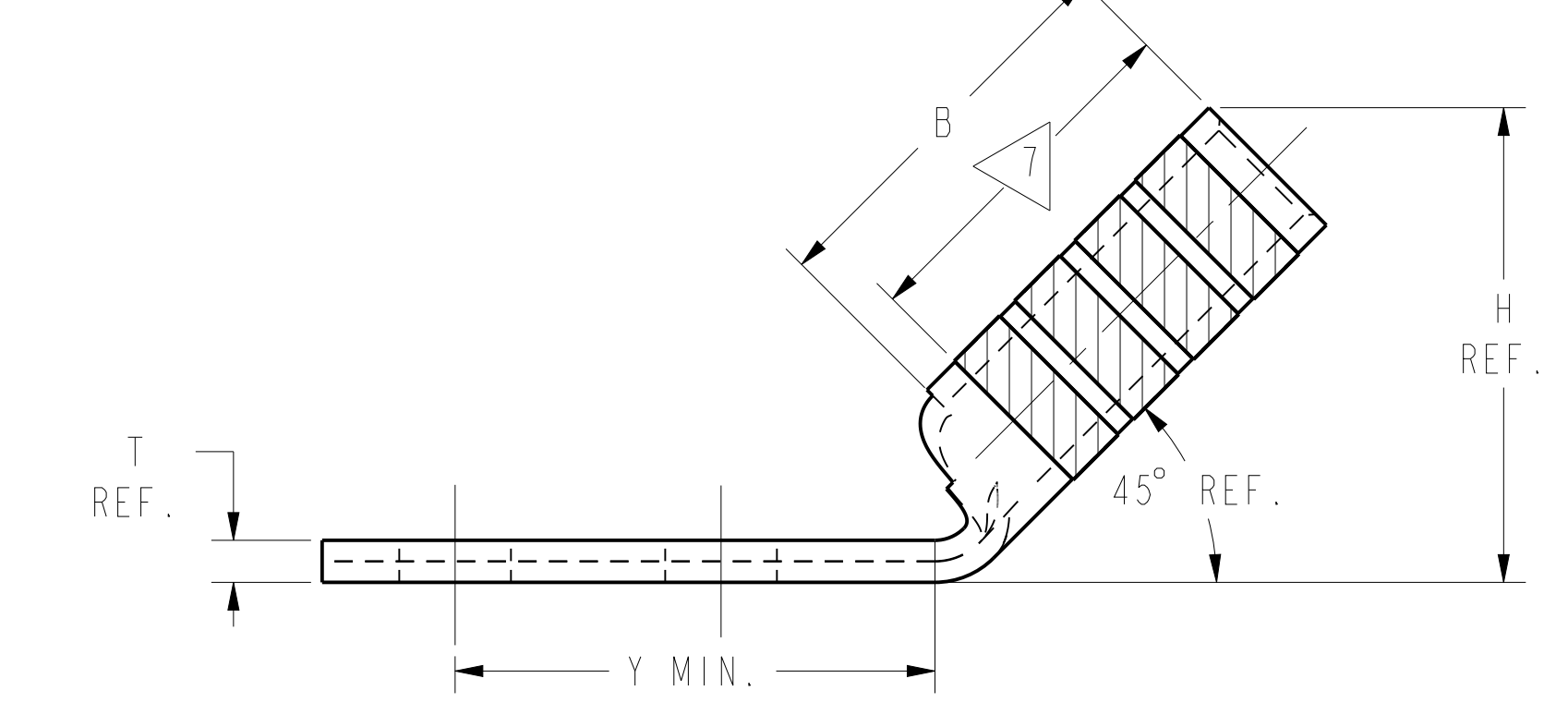
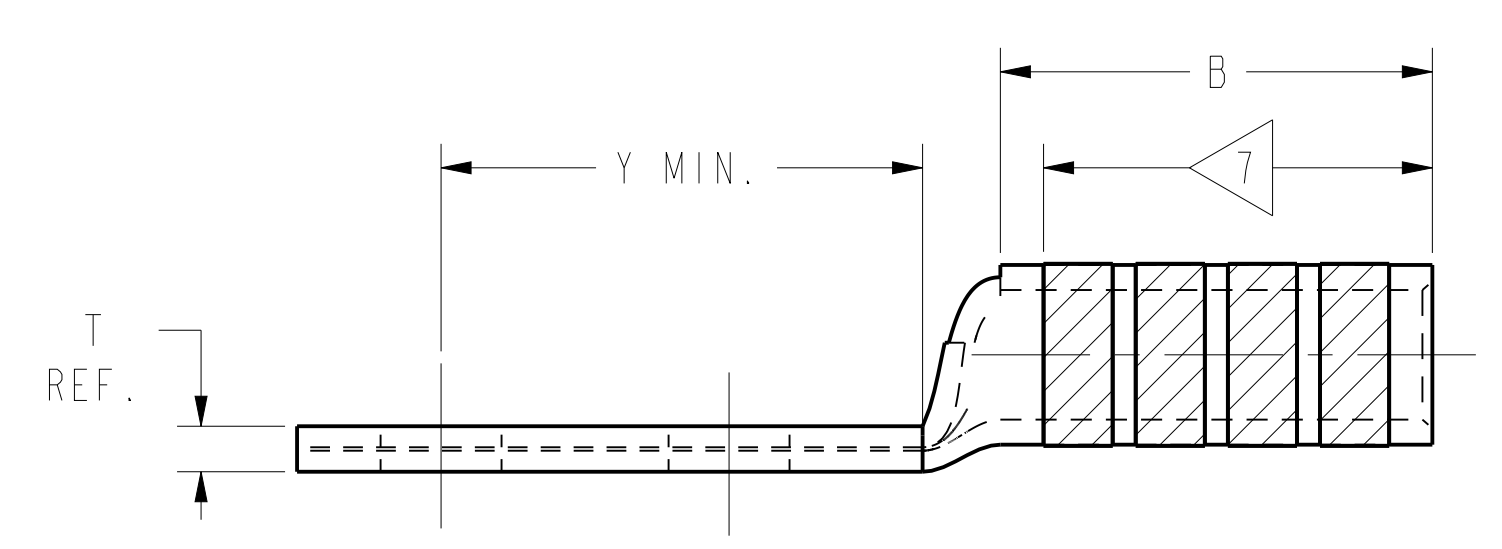
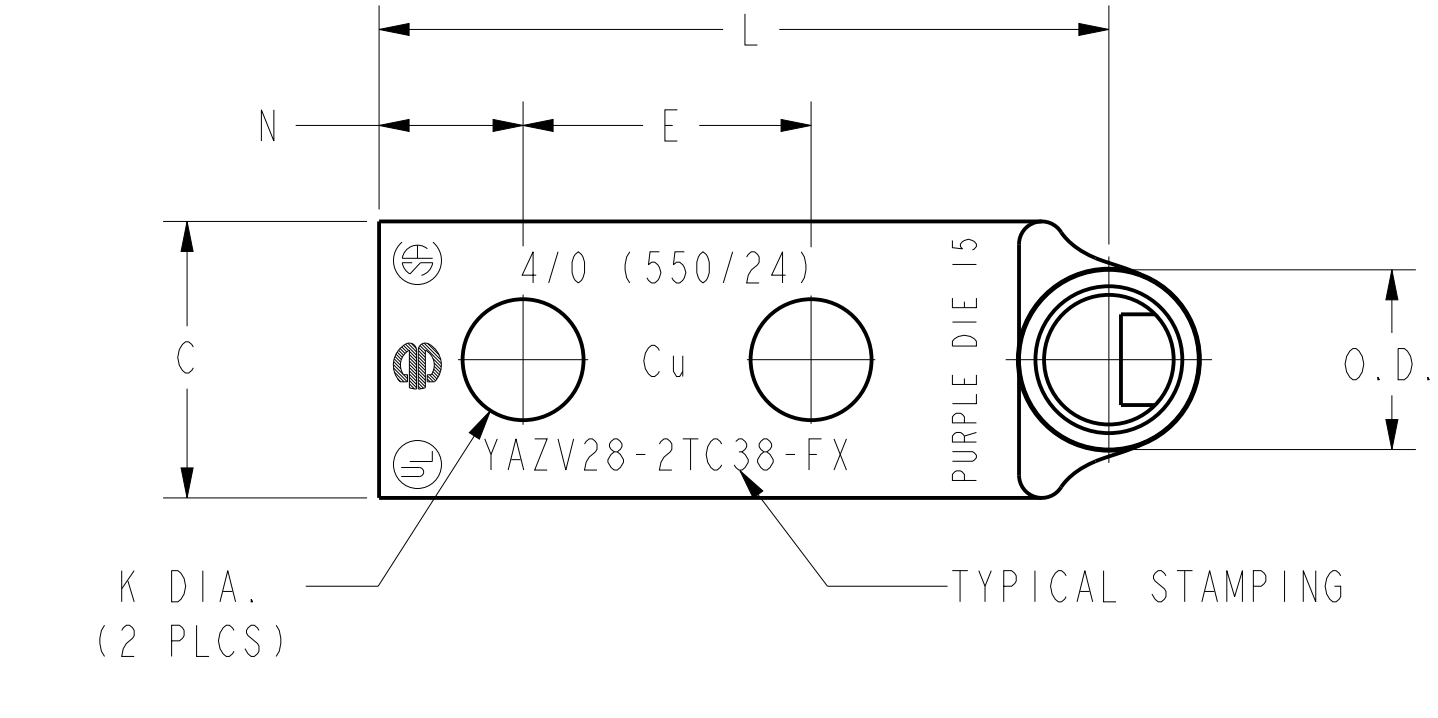
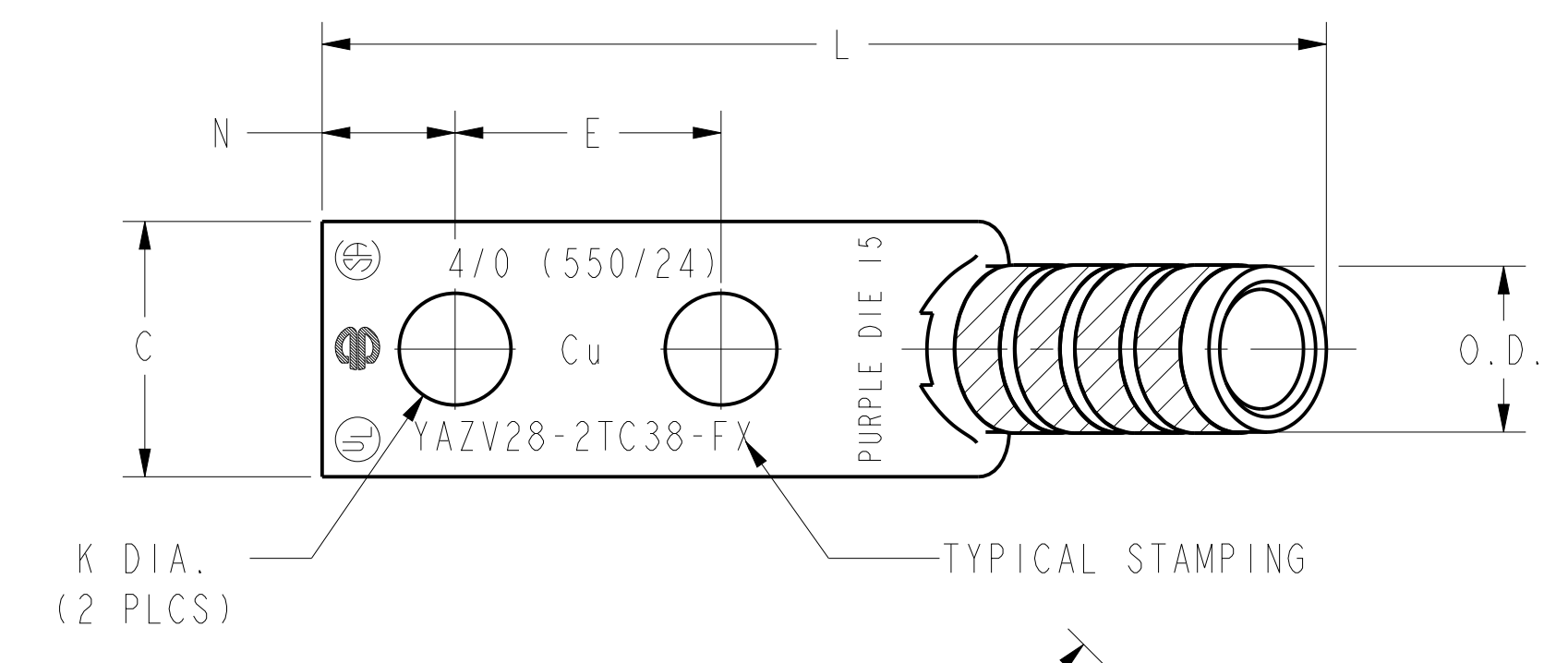
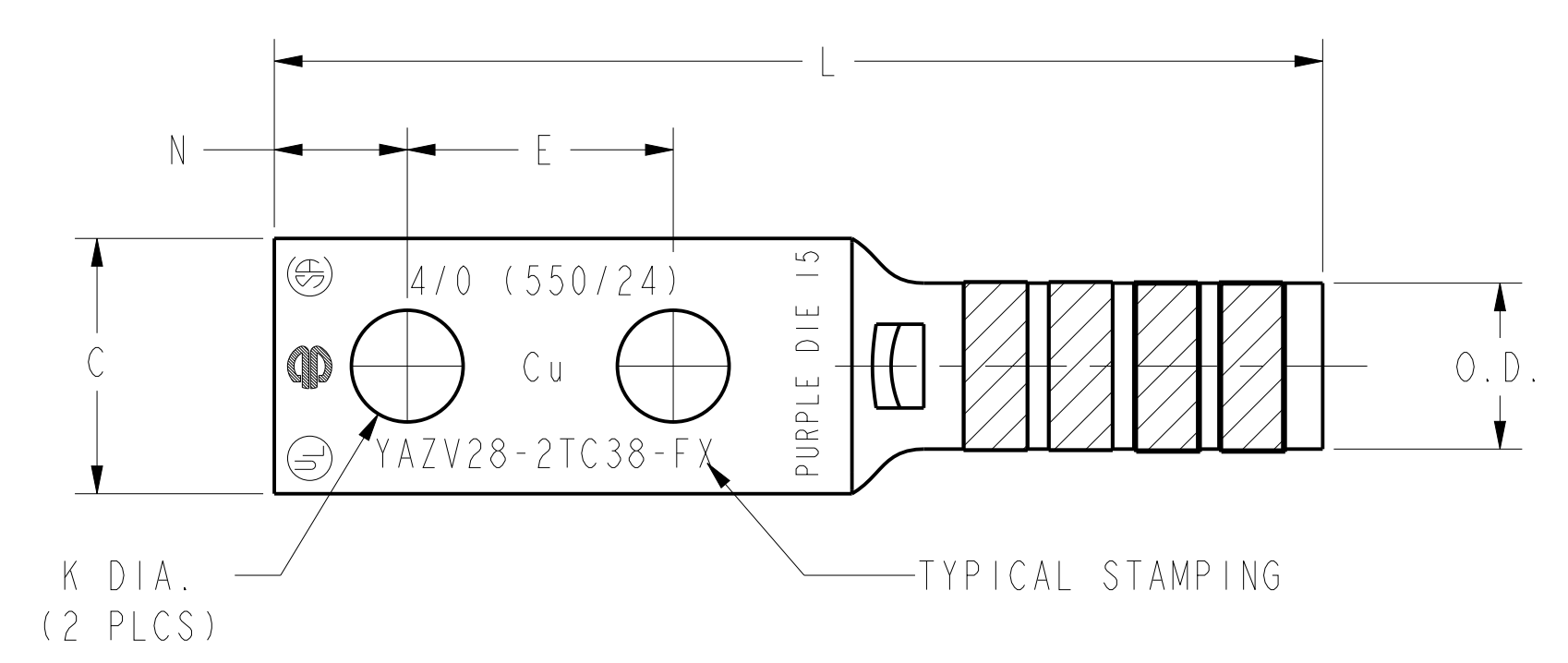

NOTES:

- MATERIAL: COPPER TUBING.
- FINISH: TIN PLATED.
- CATALOG # PT6515 ADAPTOR IS REQUIRED TO USE "U" DIES IN Y45 SERIES TOOLS.
- CATALOG # PUADP-1 ADAPTOR IS REQUIRED TO USE "U" DIES IN Y46 SERIES TOOLS.
- PERMANENT DIE IN TOOLING.
- DIMENSIONS IN BRACKETS [] ARE IN MILLIMETERS ROUNDED OFF TO THE NEAREST MILLIMETER, UNLESS OTHERWISE NOTED, AND ARE FOR REFERENCE ONLY.
- CRIMP (# OF CRIMPS PER TABLE) WITHIN THE LENGTH BETWEEN THE INK STAMPED CRIMPING AREA.

TO ORDER BURNDY® PRODUCTS CALL		HYLUG™ (TWO HOLE FLEX)	
UNITED STATES 1-800-346-4175 (LONDONDERRY, NH)		ITEM NO: N/A	CAT. NO: YAZV28- (TABLE)
CANADA: 1-800-361-6975 (QUEBEC) 1-800-387-6487 (ALL OTHER PROVINCES)		DRAWN BY: B MICHAUD 8/25/99	CHECKER: K HENRY 8/26/99
FOR PRODUCT INFO: http://www.burndy.com		DSN APPVL: RR TEAM 9/28/99	MFG APPVL: --
		GA APPVL: J BRODEUR 10/6/99	MKT APPVL: R ROBICHEAU 10/5/99
		PROD FAM: --	SCALE: NTS
		PROJECT #: --	SIZE: D
		DOCUMENT TYPE: Sales	DRAWING NO: SE212273
		REL LEVEL: Released	SHEET 31 OF 48