

CATALOG NO.	CONDUCTOR		BOLT SIZE	FIG. NO.	DIMENSIONS									INSTALLATION TOOLING (# CRIMPS)									
	CODE (AWG)	NAVY \triangle 5			B	C	H	K DIA.	L	N	O.D.	T REF.	Z MIN.	DIE INDEX	COLOR CODE	MECHANICAL			HYDRAULIC			DIELESS (# CRIMPS)	WIRE STRIP LENGTH
					$\pm .04$	$\pm .04$	REF.	$\pm .02$	$\pm .06$	$\pm .03$	$\pm .01$												
YAZV10TC14	14-10			1			--		1.52 [39]												RATCHET, Y8MRB-1 MR8G98 (2) CRIMPS NON-RATCHET Y10D Y14MV (2) CRIMPS	3/4	
YAZV10TC1445	[2.5mm ² STR 4mm ² SOL 4mm ² STR]	---	1/4 [M6]	2	.69 [18]	.41 [10]	.77 [20]	.27 [7]	1.40 [36]	.31 [8]	.21 [5]	.05 [1]	.33 [8]	---	---	---	---	---	---				
YAZV10TC1490				3			.94 [24]		.82 [21]														

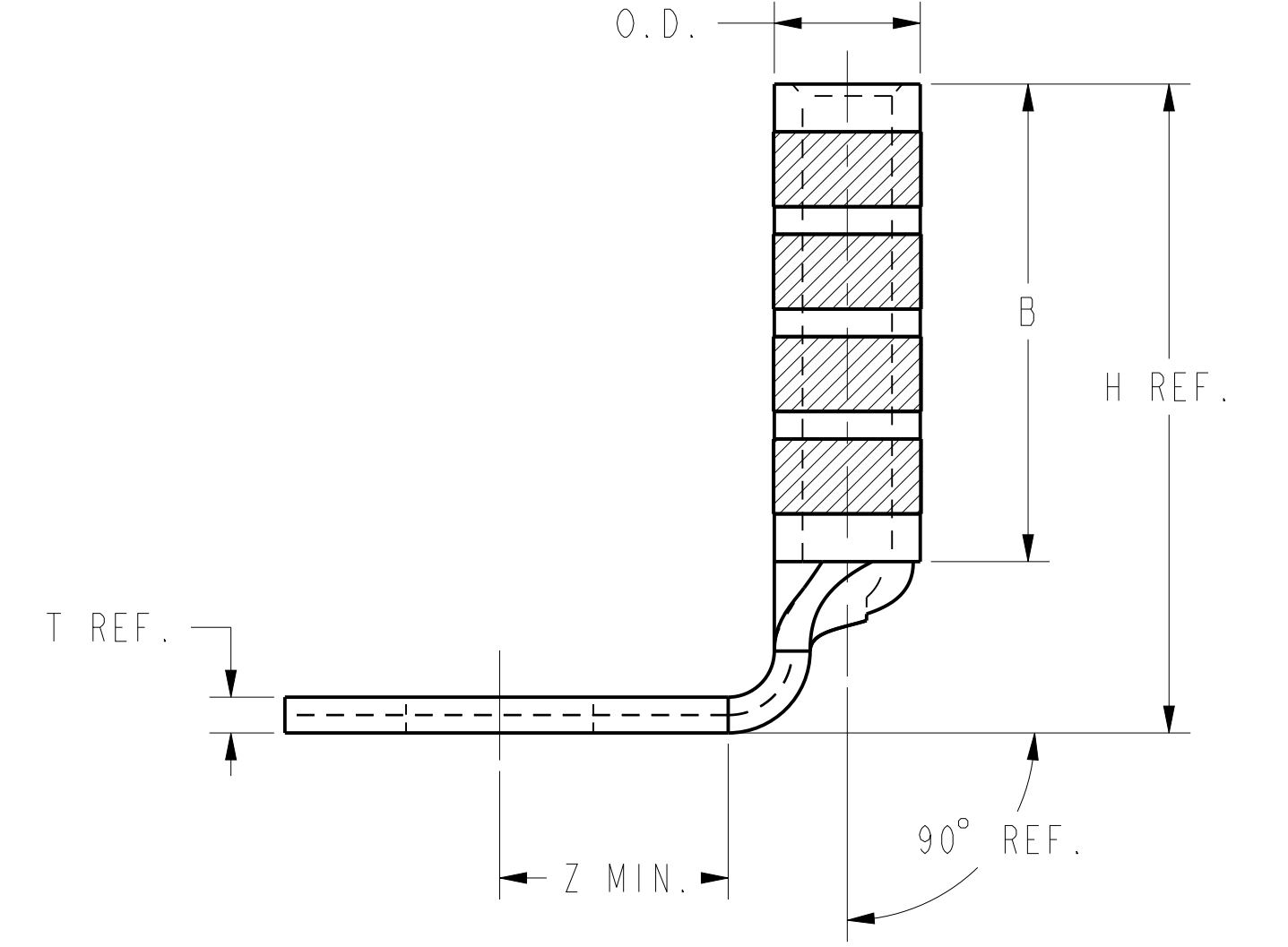
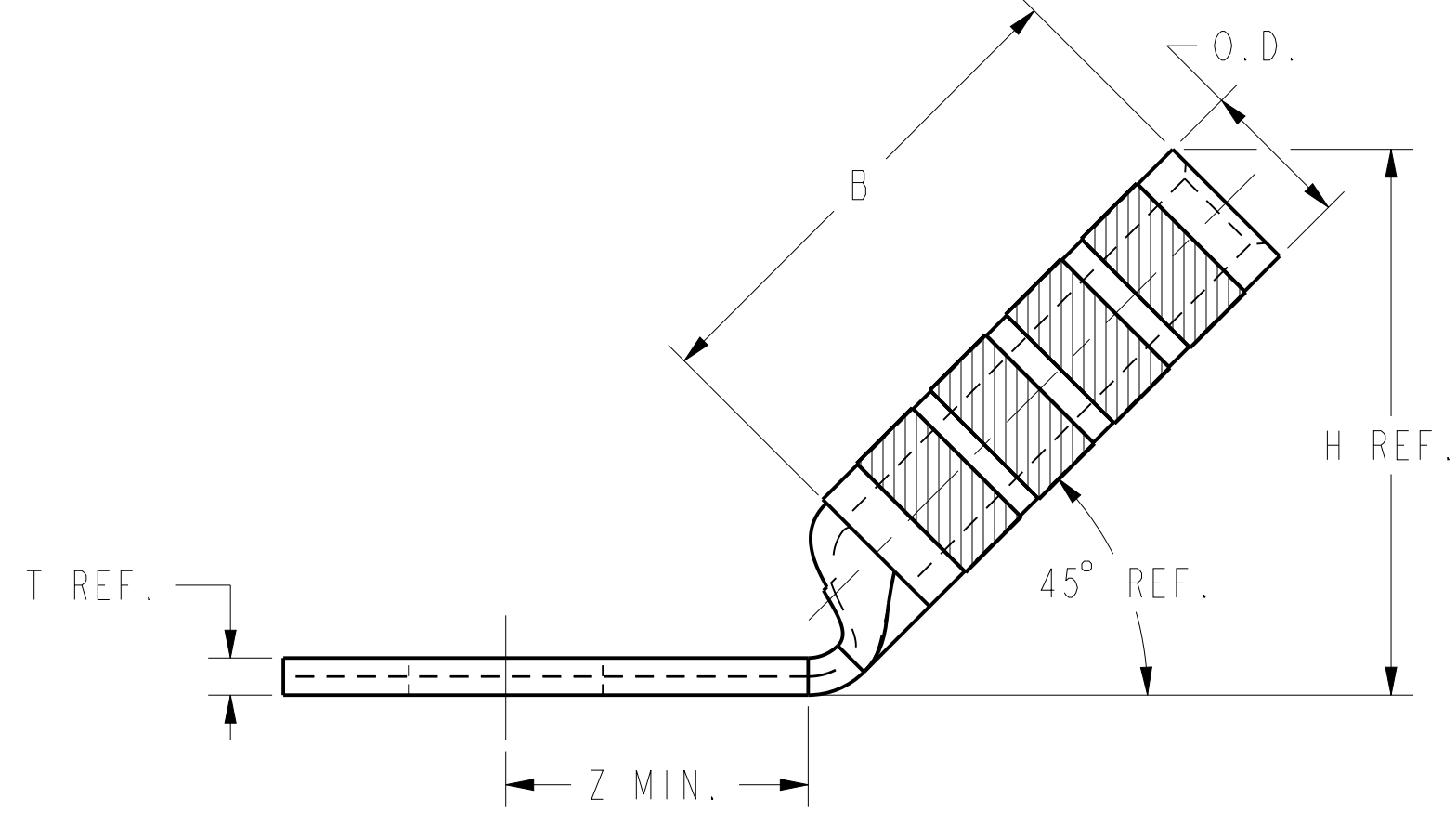
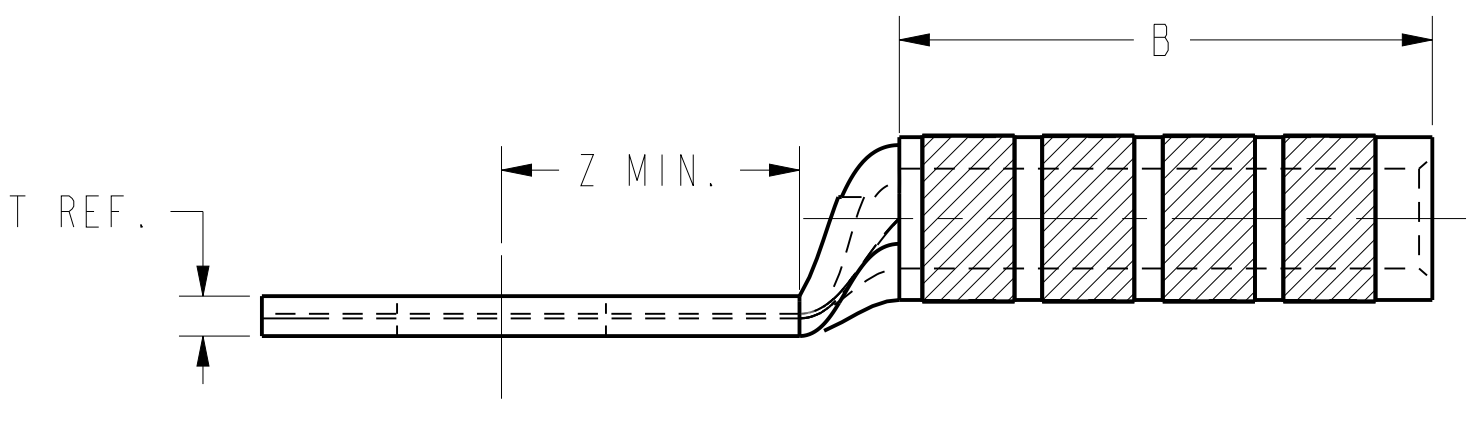
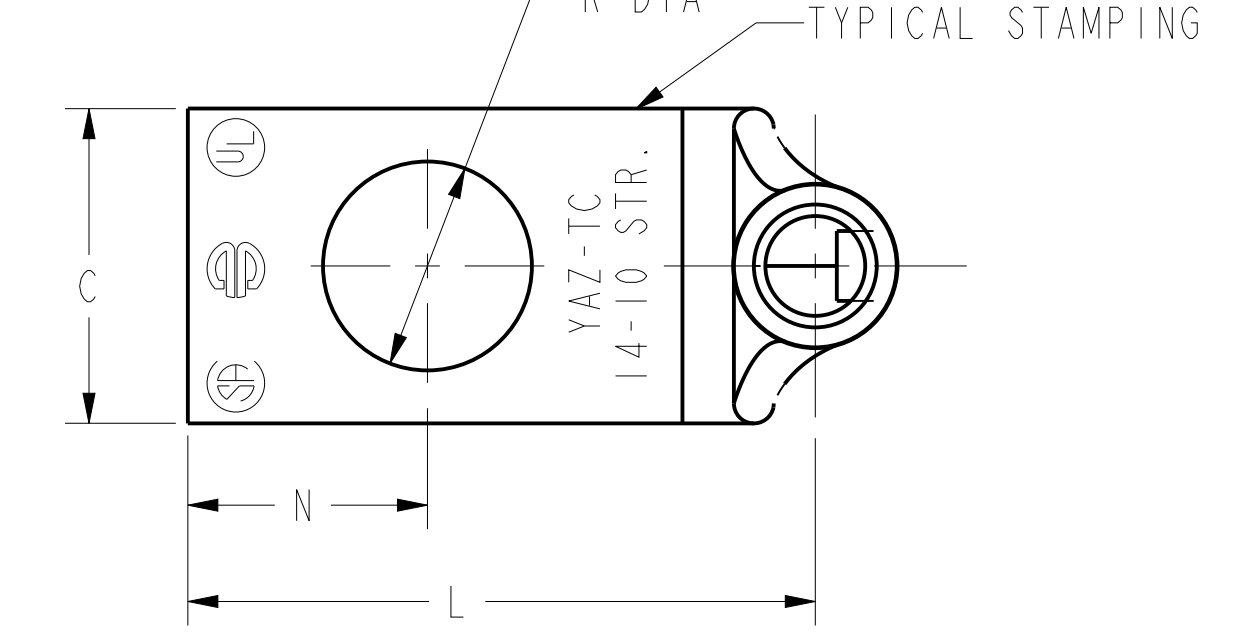
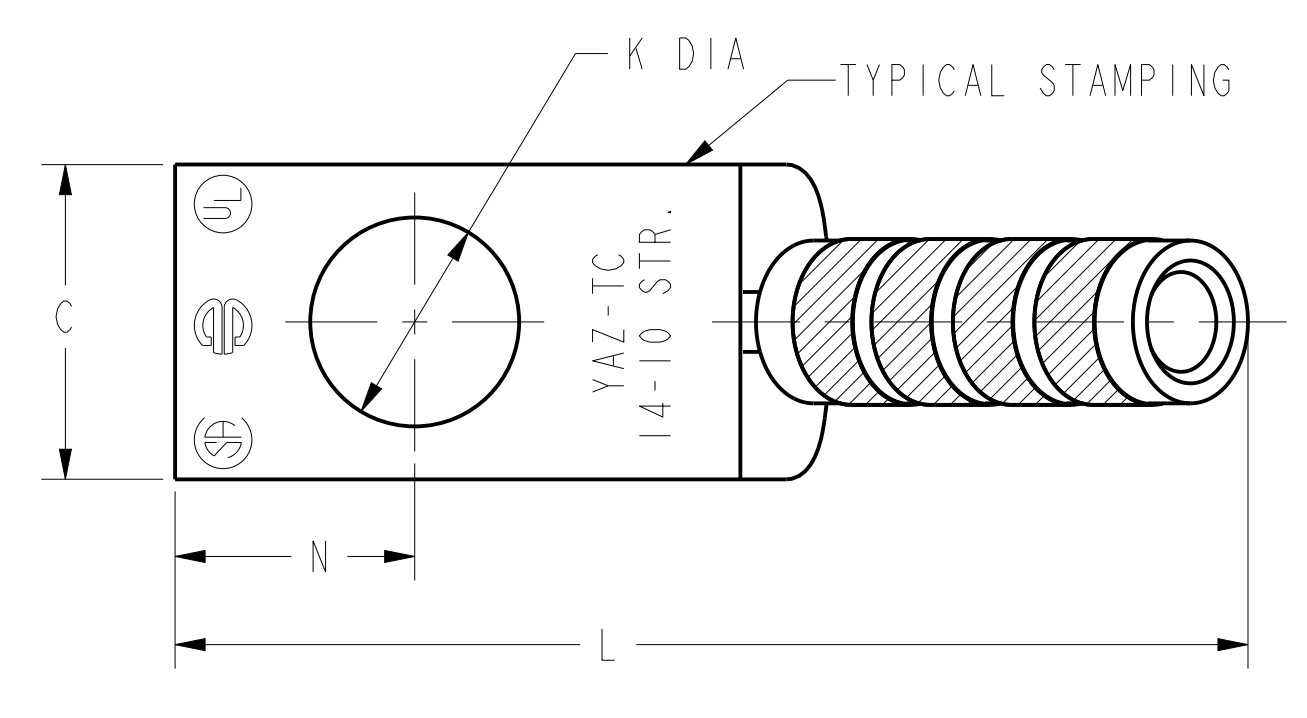
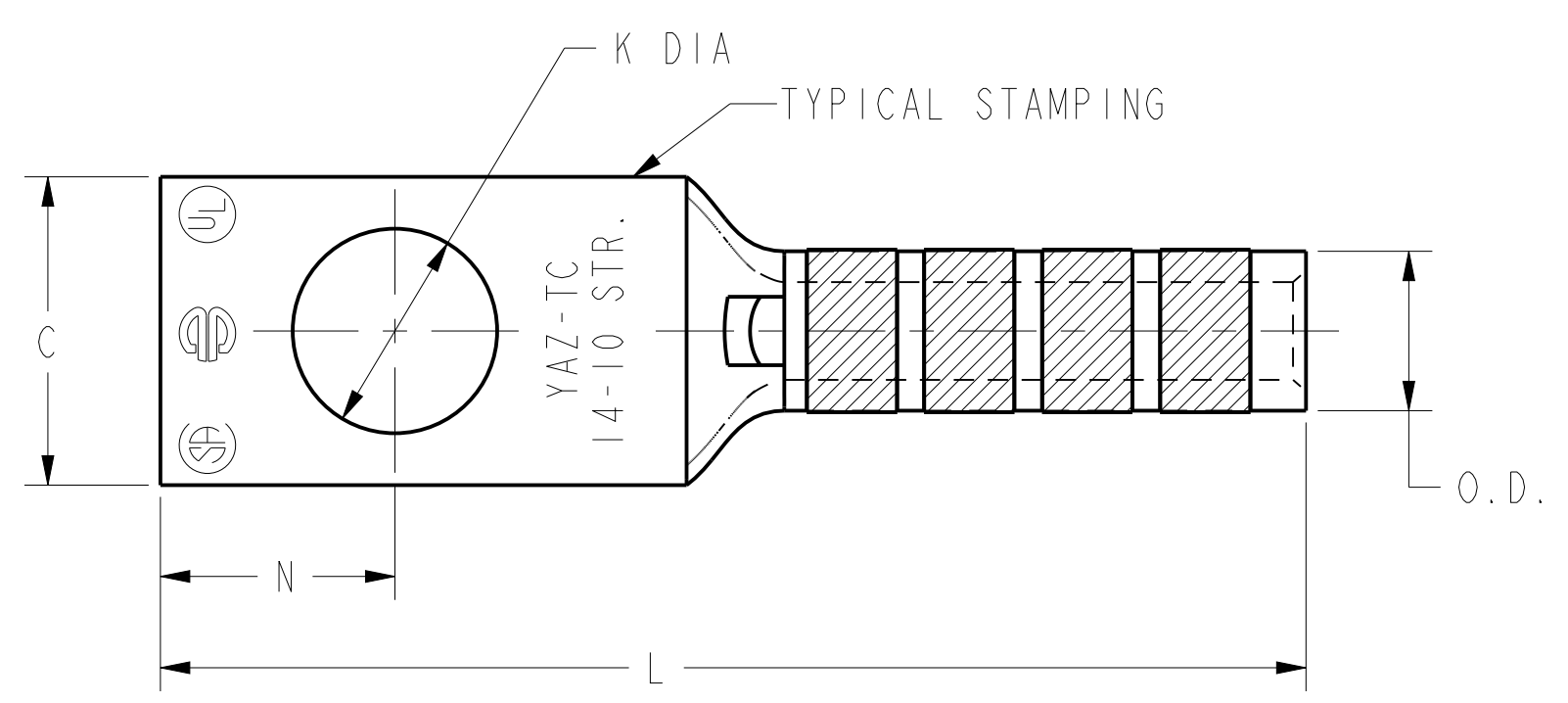

FIG. 1

FIG. 2

FIG. 3

NOTES:

- MATERIAL: COPPER TUBING.
- FINISH: TIN PLATED
- CATALOG # PT6515 ADAPTOR IS REQUIRED TO USE "U" DIES IN Y45 SERIES TOOLS.
- CATALOG # PUADP-1 ADAPTOR IS REQUIRED TO USE "U" DIES IN Y46 SERIES TOOLS.
- NAVY CABLE SIZE MAY BE OMITTED ON SOME SIZES BECAUSE OF SPACE LIMITATIONS.
- PERMANENT DIE IN TOOLING.
- DIMENSIONS, METRIC WIRE, & METRIC BOLT SIZES IN BRACKETS [] ARE IN MILLIMETERS. DIMENSIONS ARE ROUNDED OFF TO THE NEAREST MILLIMETER, UNLESS OTHERWISE NOTED, AND ARE FOR REFERENCE ONLY.

TO ORDER BURNDY® PRODUCTS CALL		HYLUG™ (ONE HOLE CODE)	
UNITED STATES 1-800-346-4175 (LONDONDERRY, NH)		ITEM NO: NA	CAT. NO: YAZV10-TC- (TABLE)
CANADA: 1-800-361-6975 (QUEBEC) 1-800-387-6487 (ALL OTHER PROVINCES)		DRAWN BY: D. BOISVERT 02/03/2000	CHECKER: K. MCCARTHY 04/05/2000
FOR PRODUCT INFO: http://www.burndy.com		DSN APPVL: J. MICHAUD 05/04/2000	MFG APPVL: N/A
		GA APPVL: S. BROWN	MKT APPVL: R. ROBICHEAU 02/01/2000
		PROD FAM: --	SCALE: NTS
		PROJECT #: --	DRAWING NO: SE212356
		DOCUMENT TYPE: Sales	REV: B
		REL LEVEL: Released	SHEET 1 OF 40

REV: PEC200