

REV	DATE	DESCRIPTION	ECO	BY	C'H'K.
B	05/08/2017 00:00:00 AM	LOGO UPDATE	46692	BK	MB

CATALOG NO.	CONDUCTOR		BOLT SIZE	FIG. NO.	DIMENSIONS								INSTALLATION TOOLING (# CRIMPS)								DIELESS (# CRIMPS)	WIRE STRIP LENGTH			
	CODE (AWG)	NAVY			B ±.03	C +.04 -.02	H REF.	K DIA. ±.02	L ±.06	N ±.04	O.D. ±.01	T REF.	Z MIN.	DIE INDEX	COLOR CODE	MECHANICAL			HYDRAULIC						
																MD7-34R MD6	OUR840	Y8MRB-1 Y2MR	BCT500 Y500CT	Y34A			Y750 Y35, BAT35 Y39, BAT750	Y46	Y45
YAZ5CTC12	#5 AWG. [16mm ² STR]	30	1/2 [M12]	1																MECHANICAL, MY29-11(1) HYDRAULIC Y644, Y644M BAT644M Y644MBH, Y1000 Y1000BH (1)	1-3/16				
YAZ5CTC1245				2	1.12 [28]	.83 [21]	1.22 [31]	.52 [13]	2.36 [60]	.53 [13]	.30 [8]	.12 [3]	.55 [14]	7 OR 374	BLUE	W5CVT W5CRT (2)	W5CVT W5CRT (2)	BLUE (2)	W5CVT W5CRT (2)			A5CR (2)	U5CRT U8CABT (2)	U5CRT U8CABT (2)	U5CRT U8CABT (2)
YAZ5CTC1290				3		1.60 [41]		1.33 [34]																	

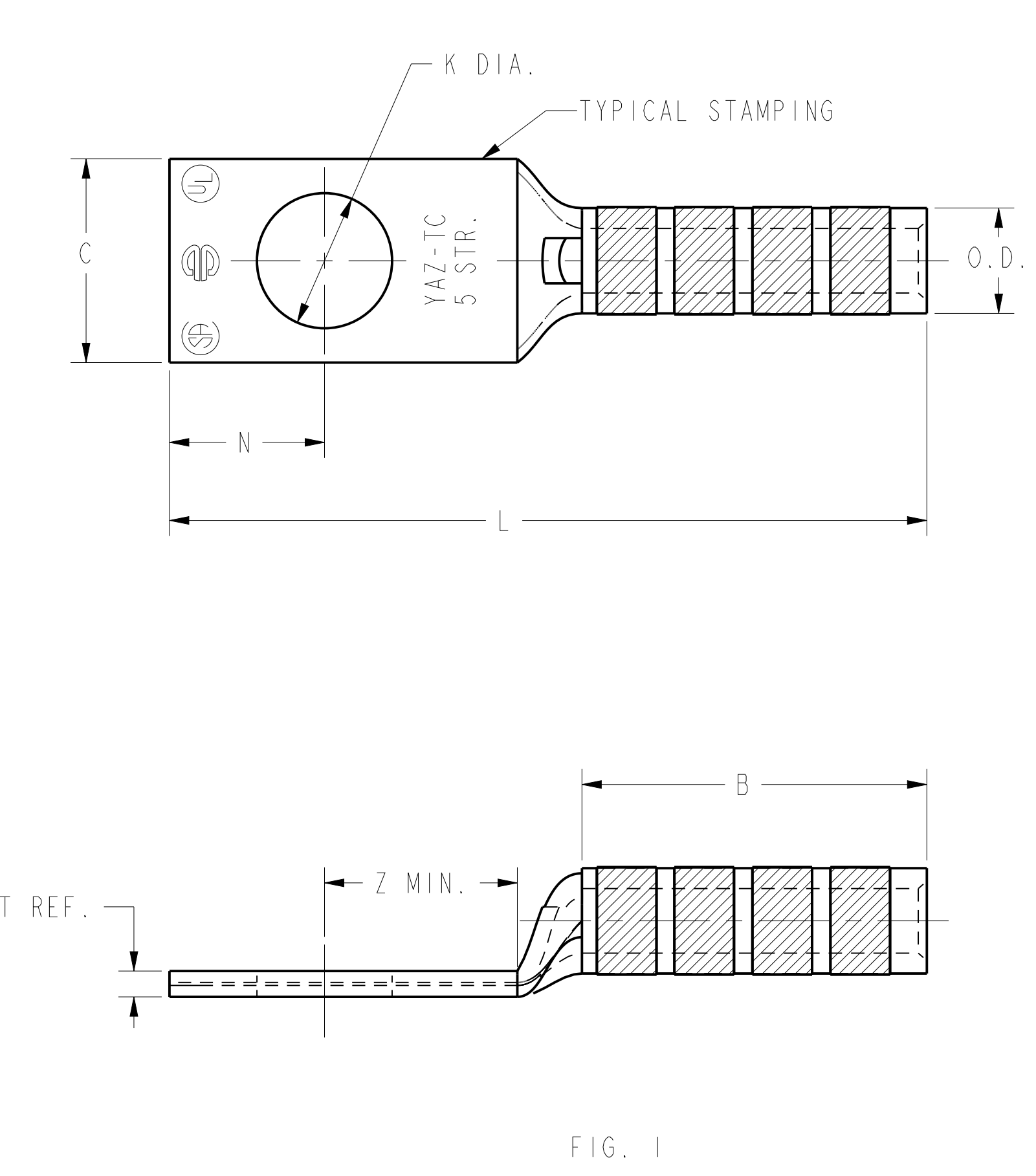

FIG. 1

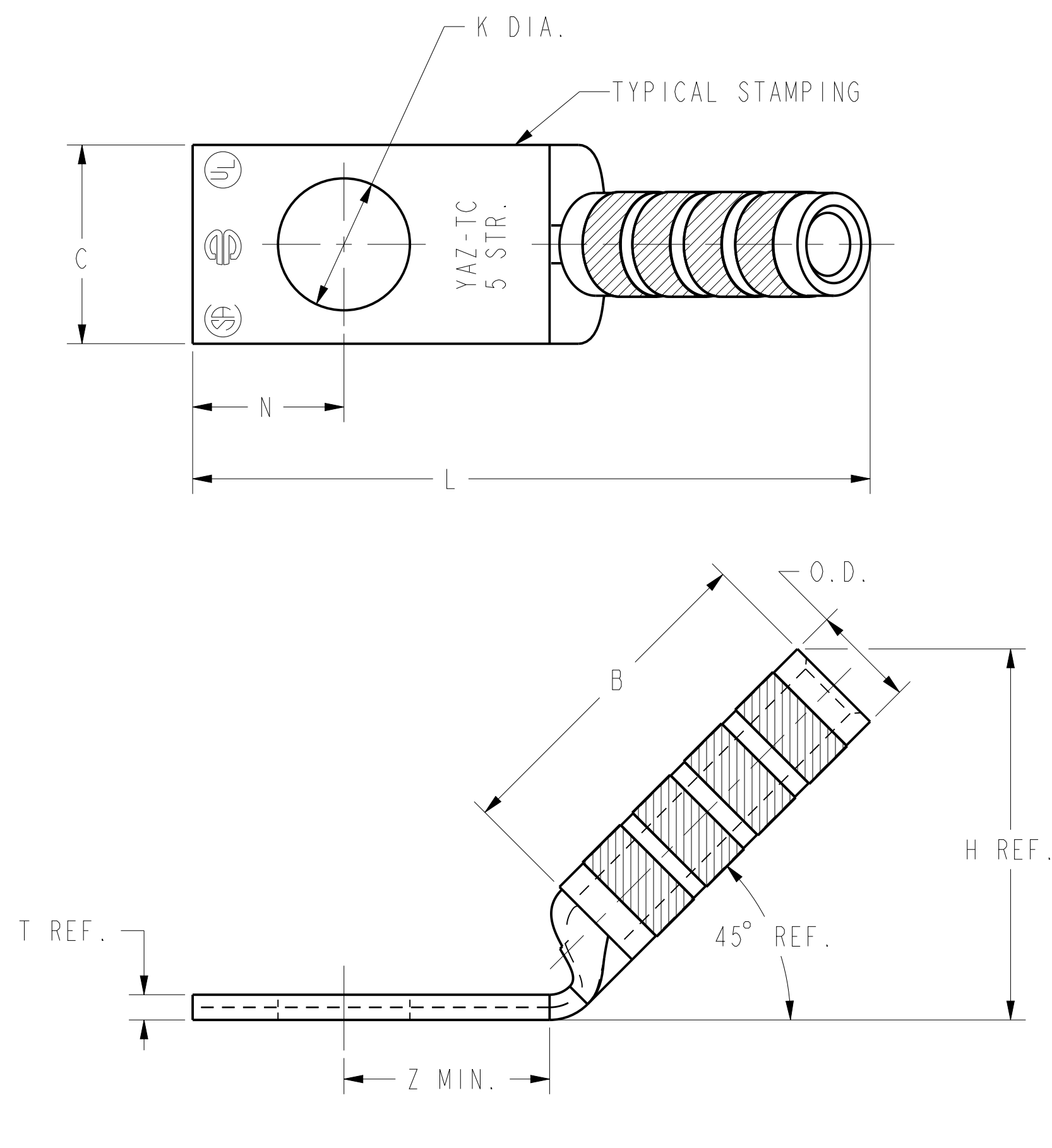

FIG. 2

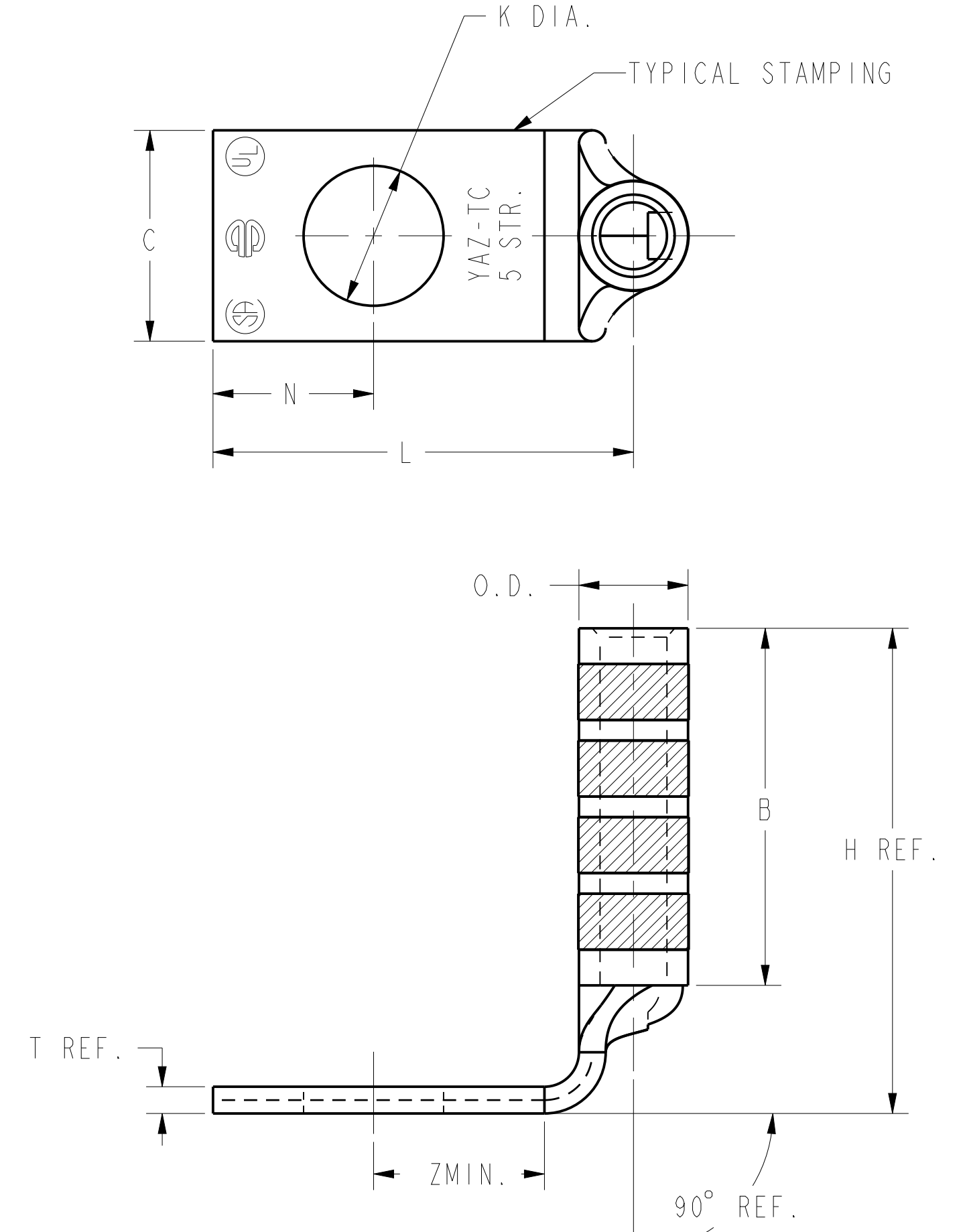

FIG. 3

- NOTES:
1. MATERIAL: COPPER TUBING.
 2. FINISH: TIN PLATED
 3. CATALOG # PT6515 ADAPTOR IS REQUIRED TO USE "U" DIES IN Y45 SERIES TOOLS.
 4. CATALOG # PUADP-1 ADAPTOR IS REQUIRED TO USE "U" DIES IN Y46 SERIES TOOLS.
 5. NAVY CABLE SIZE MAY BE OMITTED ON SOME SIZES BECAUSE OF SPACE LIMITATIONS.
 6. PERMANENT DIE IN TOOLING.
 7. DIMENSIONS, METRIC WIRE, & METRIC BOLT SIZES IN BRACKETS [] ARE IN MILLIMETERS. DIMENSIONS ARE ROUNDED OFF TO THE NEAREST MILLIMETER, UNLESS OTHERWISE NOTED, AND ARE FOR REFERENCE ONLY.
 8. FOR USE BY CUSTOMERS THAT HAVE THIS HYPRESS™. NO NEW Y34A HYPRESS™ TOOLS ARE BEING PROCESSED.

TO ORDER BURNDY® PRODUCTS CALL		HYLUG™ (ONE HOLE CODE)	
UNITED STATES 1-800-346-4175 (LONDONDERRY, NH)		ITEM NO: NA	CAT. NO: YAZ5C-TC- (TABLE)
CANADA: 1-800-361-6975 (QUEBEC) 1-800-387-6487 (ALL OTHER PROVINCES)		DRAWN BY: D. BOISVERT 02/03/2000	CHECKER: K. MCCARTHY 04/05/2000
FOR PRODUCT INFO: http://www.burndy.com		DSN APPVL: J.MICHAUD 05/04/2000	MFG APPVL: N/A
		GA APPVL: S.BROWN	MKT APPVL: R.ROBICHEAU 02/01/2000
		PROD FAM: --	SCALE: NTS
		PROJECT #: --	DRAWING NO: REV
		DOCUMENT TYPE: Sales	SE212356
		REL LEVEL: Released	SHEET 6 OF 40



REV: PEO200